

LORS-TECNA ROCKER ARM RESISTANCE WELDERS

SPECIFICATIONS

LTR MODEL:	4604NA	4606NA	4609NA	4611NA
TYPE:	FOOT OPERATED ROCKER ARM		AIR OPERATED ROCKER ARM	
TRANSFORMER:	Water-Cooled, Dual Voltage Compact High Output Type			
KVA RATING @ 50% Duty Cycle: Maximum Short Circuit:	20 40	25 45	20 40	25 45
SECONDARY CURRENT (A): Short Circuit	13,500	15,000	13,500	15,000
SECONDARY VOLTAGE (V):	2.75 - 3.8			
WATER COOLING: (gallons per hour)	47 gph	58 gph	47 gph	58 gph
ELECTRICAL CONNECTIONS:	220V-440V/1 PHASE/60 Hz.			
RECOMMENDED CABLE: For not more than 5% Voltage drop in 100 feet	220V 1AWG		440V 6AWG	
FUSE RATING:	70A		40A	
INITIATION:	Standard Manual Footswitch (adjustable in length)		Standard Dual Stage Electric Footswitch (2nd footswitch receptacle for dual current operation)	

WELDER CONTROL: TE 90

- Built-in Digital Solid State Microprocessor Control with LED display and indicators.
- Synchronous Control with thyristor; insulated water-cooling and over-temperature protection.
- Phase Shift control adjustable from 20% to 100%, weld time adjustable from 1 to 99 cycles to allow precision welding.
- Simplified programming by means of four push-buttons.
- Dual pre-setting for time and current selectable by optional second footswitch.
- Parameters include: Squeeze, Weld, Hold, Off times, Dual Currents, Pulsation, Upslope and Single Spot or Auto Repeat functions.
- Secondary current compensation function for welding of oxidized sheets and rods.
- Auto-Retain disabling for manually operated welders.
- First Phase Shift Delay adjustment.
- Maintenance free SCR Contactor.

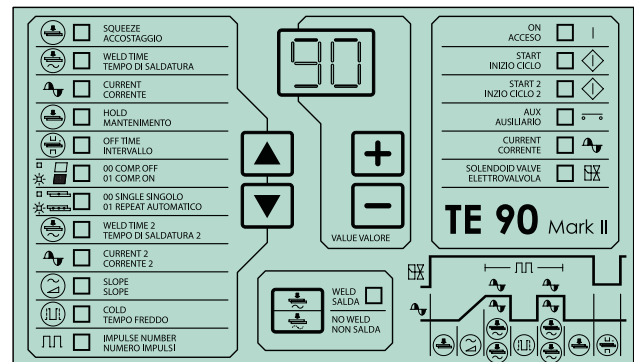

ARM DIAMETER: 1-1/2" Diameter

ELECTRODE HOLDERS: 1" Diameter

ELECTRODE TIPS: 1MT/4RW

DISTANCE BETWEEN ARMS:

4604NA: 8-5/8" 4606NA: 8-5/8"
4609NA: 8-5/8" 4611NA: 8-5/8"

NET WEIGHT:

4604NA: 290 Lbs. 4606NA: 295 Lbs.
4609NA: 286 Lbs. 4611NA: 290 Lbs.

DIMENSIONS:

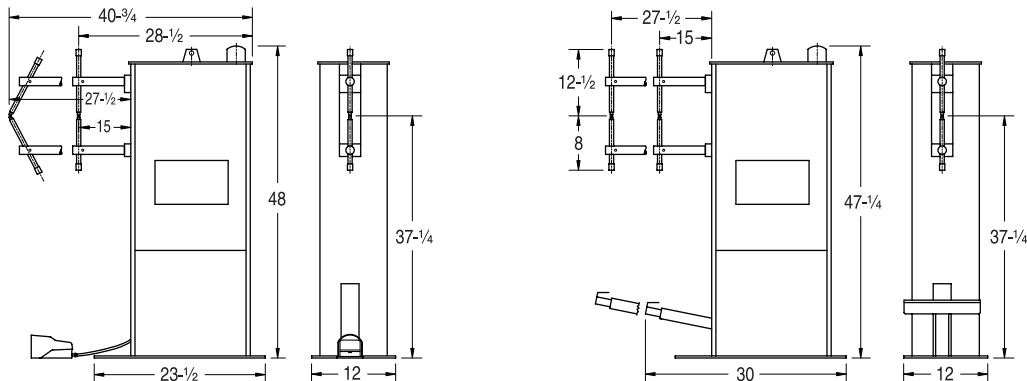

Specifications are subject to change without notice.