

NEW MODELS
ADDED (20, 26, 32)



CDX-HW(-C) Series

Horizontal Recessed
Ceiling Fan Coil

1 1/2 - 3 Tons Cooling
Up to 51,700 BTUH HW Heat

NEW OPTION:
MERV 8 FILTER PANELS

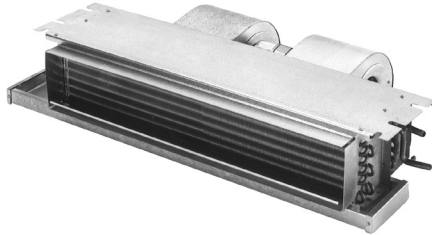

CDX-HW Fan Coil
(without enclosure)



Optional Access Panel
(non-louvered shown)

The space-saving **CDX-HW** series fan coil is only 10" high (11" with enclosure), thus allowing it to recess in a ceiling. Recessed ceiling fan coils save valuable floor space and eliminate costly "equipment" closets.

(1) First Co's customer is ultimately responsible for confirming which fan coil models are compatible with selected outdoor unit(s) and which expansion valves are required. To determine certified indoor/outdoor matches, go to www.firstco.com or contact the factory.

All **CDX-HW** fan coils include a 120/24V transformer and are completely prewired. A sloped drain pan allows positive drainage of condensate.

(-C) model: for **CDX-HW** fan coils installed within an enclosure, add **"-C"** after **CDX-HW**. For instance, ordering model **18CDX-HW-C** will include a **CDX-HW** fan coil factory installed in a # **9ECDX01** enclosure and your choice of either a solid or louvered panel.

These fan coils are compatible with any source of hot water that doesn't exceed 180°F.

Standard Features:

- **Factory installed service switch**
- **Freeze protector on HW coil**
- Two speed fan operation
- Drain pan has 3/4" NPT primary and secondary (overflow) fittings
- 120V motor, 24V controls
- Highly efficient copper tube/aluminum fin heating and cooling coils. Cooling coil has a piston-type metering device or factory or field installed R410A TXV's (non-bleed type). Contact factory for correct match with outdoor unit.
- Insulated and coated galvanized steel drain pan is sloped for proper drainage
- Effective January 2016, Cabinet air leakage is no more than 2% when tested in accordance with ASHRAE 193.

Optional Accessories:

- Attractive off-white return air / access panel with captive screws (panels can be field painted)
- **IAQ filter panels** (see P. 3)
- Fully insulated enclosure with matching ceiling panel (enclosure can be pre-installed). Also allows for ducted return air.
- Factory or field installed TXV's (non-bleed type)
- Pump module - used when the hot water source is a gas-fired water heater (part # **940-3CV**) (field installed)
- Condensate overflow switch (field installed) (# **SS3**)

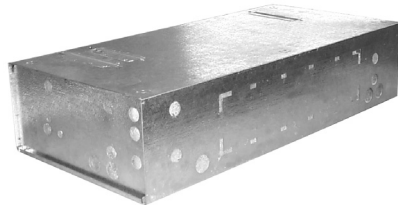

Optional Insulated Enclosure



Matching Access Panel for Enclosure
(non-louvered shown)

CDX-HW(-C) Series

1-1/2 through 3 tons

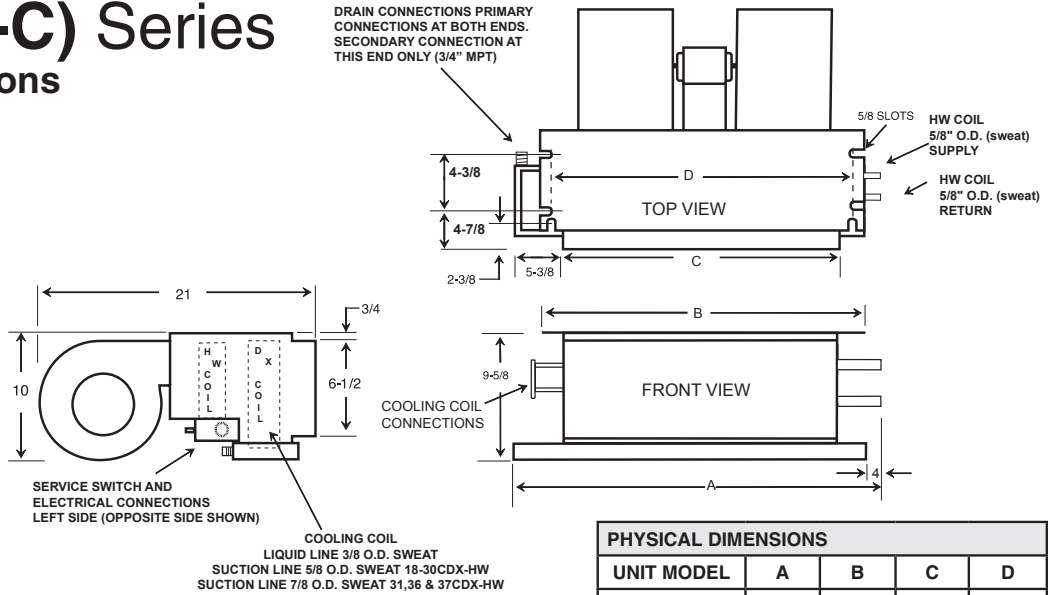

PHYSICAL DIMENSIONS				
UNIT MODEL	A	B	C	D
18/19CDX-HW	38-1/8	37-1/4	30-1/8	34-3/4
20-25CDX-HW	44-1/8	43-1/4	36-1/8	40-3/4
26-31CDX-HW	50-1/8	49-1/4	42-1/8	46-3/4
32-37CDX-HW	57-1/8	56-1/4	49-1/8	53-3/4

(See P. 4 for Model Numbers)

BLOWER DATA													
UNIT MODEL	MOTOR (1)		MOTOR HP (120V)	MIN. CKT. AMPACITY (120V)	MAX. CKT. PROTECTION	CFM vs. EXTERNAL STATIC PRESSURE (3)							
	RPM	AMPS				0.05	0.10	0.15	0.20	0.25	0.30	0.35	0.40
18CDX-HW	1550	1.9	1/8	3	15	720	690	660	630	600	570	535	500
19/20CDX-HW	1550	2.3	1/5	3	15	710	680	650	620	590	560	530	500
24CDX-HW	1550	3.0	1/5	4	15	860	840	825	810	785	740	700	660
25/26CDX-HW	1550	3.6	1/4	5	15	880	840	800	760	720	680	640	600
30CDX-HW	1550	3.6	1/4	5	15	1050	1025	1000	970	930	890	845	800
31CDX-HW	1550	4.6	1/5	6	15	1100	1060	1020	980	930	880	830	780
32CDX-HW	1550	4.6	1/5	6	15	1160	1130	1095	1060	1025	990	950	910
36CDX-HW	1550	4.6	1/5	6	15	1340	1300	1250	1200	1150	1100	1050	1000
37CDX-HW	1550	4.6	1/5	6	15	1310	1260	1210	1160	1110	1060	1000	940

- (1) Units should not be applied to a system with less than 350 CFM/Ton airflow.
- (2) Motors are 120V and operate on high speed for cool and low speed for heating.
- (3) CFM vs. static at high motor speed.
- (4) Add .05 static when enclosure and/or ceiling panel are used.
- (5) 31, 32, 36 and 37CDX-HW have two motors and four blowers.

PERFORMANCE DATA						
UNIT MODEL	NOMINAL COOLING BTUH	HEATING GPM	PRESS. DROP (FT. WTR)	BTUH (1000) AT ENTERING WATER TEMPERATURE		
				120°F	140°F	180°F
18/19CDX-HW	18,000	1	0.7	10.3	14.4	22.6
		2	2.0	12.0	16.8	26.4
		3	3.3	12.9	18.0	28.3
20CDX-HW	18,000	1	0.8	10.9	15.3	24.0
		2	2.1	12.9	18.0	28.3
		3	4.1	13.7	19.2	30.2
24/25CDX-HW	24,000	2	2.1	14.7	20.6	32.4
		3	4.1	15.9	22.2	34.9
		4	6.6	16.5	23.1	36.3
26CDX-HW	24,000	2	2.2	15.7	22.0	34.6
		3	4.3	17.0	23.8	37.4
		4	6.8	17.6	24.7	38.8
30/31CDX-HW	30,000	2	2.2	17.3	24.2	38.0
		3	4.3	18.8	26.3	41.3
		4	6.8	19.6	27.5	43.2
32CDX-HW	30,000	2	2.8	18.4	25.8	40.5
		3	5.4	20.1	28.2	44.3
		4	8.5	21.1	29.5	46.4
36/37CDX-HW	36,000	2	2.8	19.7	27.6	43.4
		3	5.4	21.7	30.4	47.8
		4	8.5	22.8	31.9	50.1

EXPANSION VALVE KITS (Heat Pump or cooling only) (FIELD INSTALLED)		
PART NO.	TYPE	FOR
9EVR410-1	R410A	18 - 37CDX-HW (-C) (1-1/2 - 3 TON)

NOTES:

1. Above expansion valve kits are approved for both cooling only (non heat pump) or heat pump applications.
2. Valves are non-bleed type. Field added. Hard start kit may be required.
3. Valves have screw-on connections.

NOTES:

1. Heat BTUH is at 70 degree EAT.
2. 120 degree and 180 degree data is supplied for boiler applications.
3. Heating BTUH output will not exceed output of water heater.
4. Approved for installation with 0" clearance to combustible material.
5. Use the capacities when First Co. "Flow Control Module" is used (# 940-3CV)

Ceiling Access Panels - (For CDX-HW's installed without enclosure)

CEILING ACCESS PANELS							
FOR MODEL	PANEL NO. (STD.)	PANEL NO. (IAQ)	DESCRIPTION	CEILING PANEL OPENING		PANEL FRAME DIMS (OUTSIDE)	
18/19CDX-HW	966	966-M8	LOUVERED	24-1/2	46	27-1/2	49
	966-1	NA	NON-LOUVERED	24-1/2	46	27-1/2	49
20-25CDX-HW	967	967-M8	LOUVERED	24-1/2	52-1/2	27-1/2	55-1/2
	967-1	NA	NON-LOUVERED	24-1/2	52-1/2	27-1/2	55-1/2
26-31CDX-HW	967-6	967-6-M8	LOUVERED	24-1/2	60	27-1/2	63
	967-7	NA	NON-LOUVERED	24-1/2	60	27-1/2	63
32-37CDX-HW	967-8	967-8-MA	LOUVERED	24-1/2	67	27-1/2	70
	967-5	NA	NON-LOUVERED	24-1/2	67	27-1/2	70

STANDARD PANELS



965-1, 966-1, 967-1, 967-7



965, 966, 967, 967-6
(Louvers may differ from picture)
Louvered panels accept 20x20x1" filter
(field supplied)

IAQ PANELS



966-M8, 967-M8 (accepts 2-20x20x1 filter)
967-6-M8 (accepts 2-20x25x1 filter)
967-8-M8 (accepts 2-20x30x1 filter)
(GlasFloss © Industries Series
HV filter or equivalent is recommended)

Enclosures with Matching Ceiling Panels (Enclosures and panels are included as standard with ALL "-C" models or can be ordered separately for CDX-HW models)

ENCLOSURE DIMENSIONS					PANEL NO. (STD.)	PANEL NO. (IAQ)	DESCRIPTION	CEILING PANEL OPENING		PANEL FRAME DIMS (OUTSIDE)	
FOR MODEL	ENCLOSURE	A	B	C			(2)	W	L	W	L
18/19CDX-HW	9ECDX01 (1)	45-3/4	30-7/8	34	966	966-M8	LOUVERED	24-1/2	46	27-1/2	49
					966-1	NA	NON-LOUVERED	24-1/2	46	27-1/2	49
20-25CDX-HW	9ECDX02 (1)	51-3/4	36-7/8	40	967	967-M8	LOUVERED	24-1/2	52-1/2	27-1/2	55-1/2
					967-1	NA	NON-LOUVERED	24-1/2	52-1/2	27-1/2	55-1/2
26-31CDX-HW	9ECDX03 (1)	58-1/2	42-7/8	46-3/4	967-6	967-6-M8	LOUVERED	24-1/2	60	27-1/2	63
					967-7	NA	NON-LOUVERED	24-1/2	60	27-1/2	63
32-37CDX-HW	9ECDX04 (1)	66-1/2	49-7/8	54-3/4	967-8	967-8-M8	LOUVERED	24-1/2	67	27-1/2	70
					967-5	NA	NON-LOUVERED	24-1/2	67	27-1/2	70

(See Panel Pictures Above)

NOTES:

(1) Louvered is the "default" style and automatically shipped unless non-louvered is specified on order.

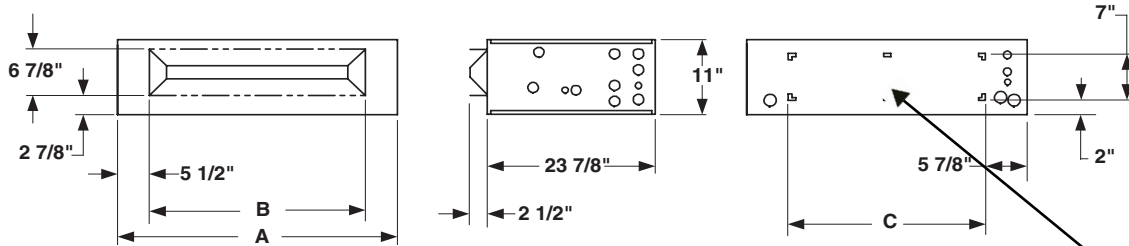

KNOCKOUT FOR DUCTED RETURN
(Ducted return requires remote filter grille
(field supplied) and non-louvered panel)



Picture shown is a "-C" model with installed CDX-HW
(Available from the factory as a complete unit)

CDX-HW(-C) Series

1-1/2 through 3 tons

MODEL NUMBERS:

MODEL SIZE (BTU)	UNCASED (NO ENCLOSURE)		FACTORY INSTALLED ENCLOSURE	
	MODEL (PISTON)	FACTORY INSTALLED TXV'S	MODEL (PISTON)	FACTORY INSTALLED TXV'S
		MODEL (R410A TXV)		MODEL (R410A TXV)
18,000	18CDX-HW	18CDX-HW R410 TXV	18CDX-HW-C	18CDX-HW-C R410 TXV
18,000	19CDX-HW	19CDX-HW R410 TXV	19CDX-HW-C	19CDX-HW-C R410 TXV
18,000	20CDX-HW	20CDX-HW R410 TXV	20CDX-HW-C	20CDX-HW-C R410 TXV
24,000	24CDX-HW	24CDX-HW R410 TXV	24CDX-HW-C	24CDX-HW-C R410 TXV
24,000	25CDX-HW	25CDX-HW R410 TXV	25CDX-HW-C	25CDX-HW-C R410 TXV
24,000	26CDX-HW	26CDX-HW R410 TXV	26CDX-HW-C	26CDX-HW-C R410 TXV
30,000	30CDX-HW	30CDX-HW R410 TXV	30CDX-HW-C	30CDX-HW-C R410 TXV
30,000	31CDX-HW	31CDX-HW R410 TXV	31CDX-HW-C	31CDX-HW-C R410 TXV
30,000	32CDX-HW	32CDX-HW R410 TXV	32CDX-HW-C	32CDX-HW-C R410 TXV
36,000	36CDX-HW	36CDX-HW R410 TXV	36CDX-HW-C	36CDX-HW-C R410 TXV
36,000	37CDX-HW	37CDX-HW R410 TXV	37CDX-HW-C	37CDX-HW-C R410 TXV

All TXV's are approved for cooling only or heat pump operation (non-bleed type).

NOTE:

Expansion valve requirement depends on the selected outdoor unit.
Go to: www.firstco.com or contact the factory for assistance.

ENCLOSURE INSTALLATION SUPPORT FRAMING

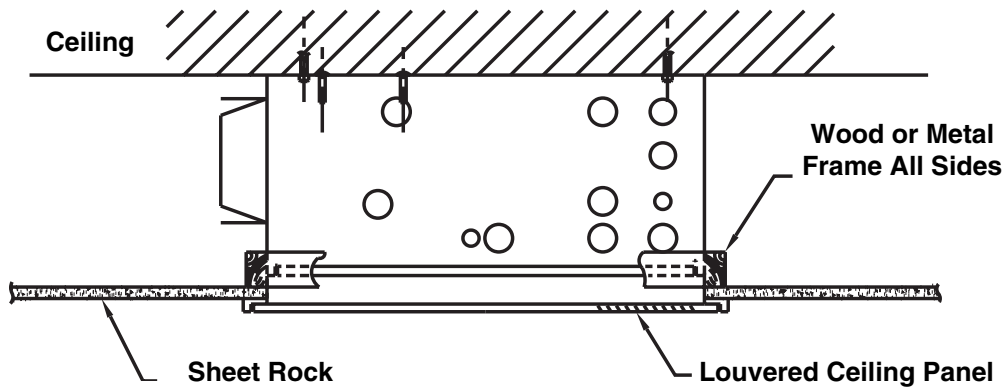

ENCLOSURE CONNECTION LOCATIONS

In keeping with its policy of continuous progress and product improvement, First Co. reserves the right to make changes without notice. Maintenance for all First Co. products is available under "Product Maintenance" at www.firstco.com.

