

The logo for AprilAire PARTNERS, featuring the brand name in a bold, sans-serif font with a stylized wave icon to the left, and the word PARTNERS in a smaller font below it.

AprilAire
PARTNERS

Dry Air Solutions

Whole-Home Humidifiers



Healthy Humidity in every home.



AprilAire

We are professional-grade Healthy Air solutions. AprilAire is on a mission to enhance people's health by improving the air in their homes. Healthy Air is essential to living a healthy lifestyle and improving our overall well-being. We are inspired by the needs of consumers and the expertise of professional contractors to create, design, and build innovative solutions.

AprilAire is Healthy Air.



5-year warranty on all installed products



Our customers are as important as the air we breathe.

We pride ourselves in providing the best service available.

- Answer all calls in 30 seconds or less
- Respond to emails within 24 hours
- Practice first call resolution
- Follow up quickly with a definitive answer if a call cannot be resolved immediately

We are only as good as our last interaction, so feedback is always welcome as we continue to strive for perfection.

Customer service agents are available Monday through Friday from 7:00 a.m. through 5:00 p.m. (CT) and can be reached by phone at 800.334.6011 or by email at support@aprilair.com.



For product advice and co-op advertising, visit aprilairpartners.com

Healthy Humidity



Health

When humidity is properly controlled within a home, it provides effective virus protection. Air that's too dry can lead to conditions that allow airborne viruses to thrive and proliferate. By adding humidity to air when needed, the amount of time a virus can survive in the air drops drastically. Beyond viruses, proper humidity control – ideally between 40–60% RH – can also help reduce the presence of other contaminants such as allergens, asthma triggers, and other respiratory irritants. A range of 40–60% RH may be considered ideal for comfort, but could cause condensation, which can subsequently cause damage to your home. AprilAire Humidifiers help maintain 35%–45% humidity in homes, helping you create better, healthier air.

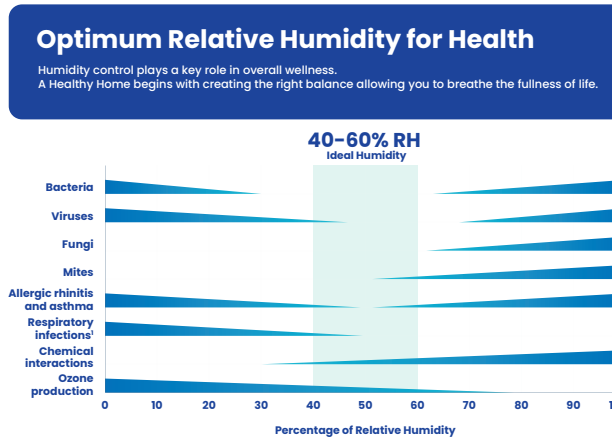

Indoor air temperature near 68°F, along with relative humidity near 50%, provides homeowners with healthy air quality while maintaining a comfortable house.



Comfort

Turning up the heat won't help make a home more comfortable if a home's relative humidity is too low. Maintaining proper humidity helps to remove the uncomfortable symptoms cold winter air can have on a home's occupants, like static shock, dry skin, and headaches.



Preservation

Humidity levels in the home greatly affect the quality, dimensions and weights of the materials used in a building's construction. Just as moisture is drawn out of human skin in dry air, so too it is drawn out of wood, leather, plaster, cloth and nearly every item in the home. It can also be damaging to some high-end electronics, musical instruments, and expensive wood floors.

In the winter, as moisture is pulled out of the wood, cracks and gaps will appear in the floor. In the summer the floors will expand again. The changes caused by these RH swings can ultimately lead to failure of the floor, leading to high replacement costs not covered by the manufacturer's warranty or the flooring installer. Make sure your customers know that wood flooring manufacturers expect consumers to maintain healthy levels of humidity to combat the effects of dry air.

The preservation benefit describes the change in the dimension of wood with a change in the surrounding RH. Heated air dries out and shrinks wood framing around doors and windows. Outside air infiltrates the home at these and additional locations, as a result of wind and chimney or stack effect.

Infiltration of outside air usually occurs at a home's envelope (perimeter walls, windows, and doors). Framing around windows and doors will not shrink or crack as much when proper RH levels are maintained inside the home. This will reduce infiltration and in turn improve energy conservation.



Energy Conservation

Dry indoor air can shrink the framing around doors and windows, resulting in gaps that let in cold air from the outside, making a home less energy efficient. When humidity is added to the air, these common points of infiltration won't shrink or crack as drastically as they might otherwise. When homes aren't letting cold air in, and the added humidity provides more comfort, heating systems don't have to work quite so hard, saving homeowners on their energy costs.



Sleep

One of the major benefits of a whole-home humidifier for your customers is protection from dry air, especially in the chilly winter months when we can become ill from seasonal flus and other viruses. A humidifier will help your customers breathe easy, protect their airways, and help get rid of pesky mucus build-up so they can sleep better.



Fresh Air Ventilation

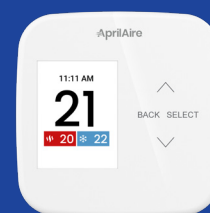

Controls



Air Filtration

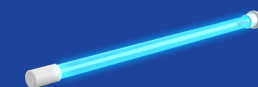

Sanitization



Radon Control



Humidity Control

Superior Performance

AprilAire Humidifiers Offer Healthy Humidity for Every Application, in Every Home.



Capacity

The average-size home requires about eleven gallons of water per day. If a humidifier can't deliver at least this much water, it is likely undersized and not recommended for most installations. AprilAire has evaporative humidifier models that can produce up to eighteen gallons per day and steam units that can provide more than thirty-four gallons per day. Refer to the sizing chart on page 8 for more information.



Ease of Installation

Besides being designed to ensure trouble-free operation and high-efficiency performance, AprilAire humidifiers were also designed to be a breeze to install. Whether it is a plenum-mounted evaporative unit or a steam unit, the installation process for all AprilAire humidifiers is fast and easy with little interruption to the customer's home.



Control

What good is having the right capacity if you don't have the control to get its moisture into the air? If the capacity is not there, you simply cannot reach the RH levels required for comfort. An AprilAire humidifier is designed not only to provide sufficient capacity, but to control it accurately.



Operational Efficiency

AprilAire Humidifiers operate efficiently with minimal maintenance required. They can maintain RH at the manually set humidistat level or automatically. When installed properly, they're engineered to give your customers peace of mind and make expensive, time-consuming call backs a thing of the past. Both our evaporative and steam humidifiers will perform to your customers' expectations and satisfaction with their precise operation.

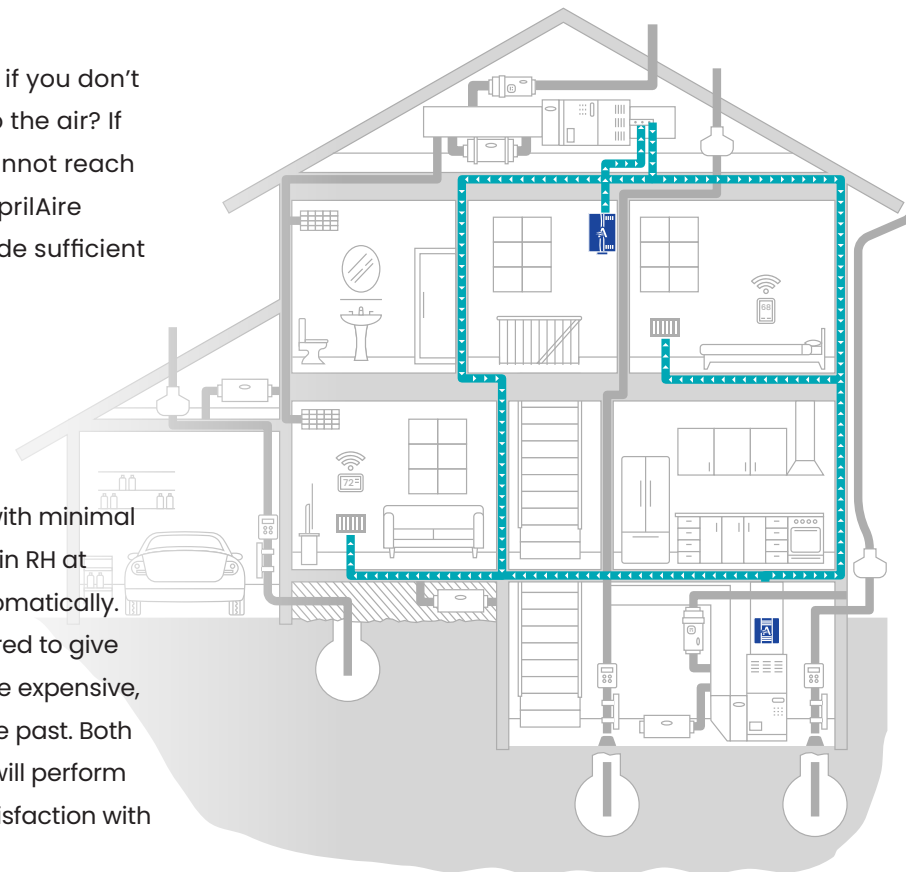

Different Climate Zones Have Different Humidity Levels but the Same Solution: AprilAire.

AprilAire Humidifiers can be installed on many different types of HVAC equipment and controlled to provide optimal humidity levels. This application guide is to assist in the selection of the appropriate AprilAire product based upon geography and heating equipment.

The AprilAire Humidifier product portfolio consists of evaporative flow through, fan-powered products and residential steam. It's important to consider the plenum temperature, air flow (fan speed) and run time (heat call primary, fan only call secondary) when selecting products.

AprilAire's control strategy will maximize the humidifier run time/capacity. The automatic humidity controls have an integrated blower activation relay. This relay is factory set to "ON". It will turn on the humidifier and the HVAC blower for humidification without a heat call. This will dramatically increase the capacity of the humidifier. Installations with a manual humidifier control can increase capacity by turning the thermostat fan to "ON". When installing evaporative humidifiers, it's recommended they are plumbed to hot water.

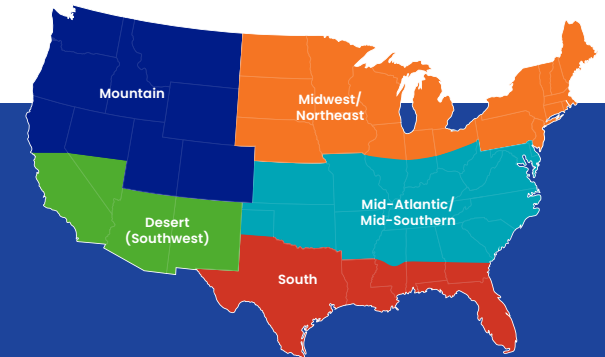

Application Map

This application map assists in the selection of the appropriate AprilAire product based upon geography and heating equipment.

CLIMATE ZONE/RECOMMENDED APRILAIRE HUMIDIFIER SOLUTION BY MODEL					
EQUIPMENT	MIDWEST/NORTHEAST	MID-ATLANTIC/MID-SOUTHERN	MOUNTAIN	SOUTH	DESERT (SOUTHWEST)
Gas/Oil Furnace-Single Stage or Multi Stage*	400/500/600/700/800	400/500/600/700/800	400/500/600/700/800	500/600/700/800	800
Gas/Oil Modulating Furnace**	700/800	700/800	700/800	700/800	800
Heat Pump/Geo-Single Stage or Multi Stage*	400†/500/600/700/800	400†/500/600/700/800	400†/500/600/700/800	500/600/700/800	800
Heat Pump/Geo-Modulating**	700/800	700/800	700/800	700/800	800
Boiler With AHU (No Heat Source)	800	800	800	800	800
Boiler With AHU and Hot Water Coil/Hydro Air Unit	700/800	700/800	800	800	800
Boiler	300/865	300/865	300/865	300/865	300/865
Electric Baseboard Heating	300/865	300/865	300/865	300/865	300/865
Humidifying with A/C Unit	800	800	800	800	800

*PSC, constant torque ECM

**Variable speed ECM

†Evaporative performance of bypass humidifiers decreases with lower airflow volume and lower air temperature. Bypass models can be used in these applications if the HVAC system pressure differential between supply and return ducts is at least 0.08 in. wg and air temperature, hot water and continuous fan in the supply duct is at least 100°F.

Evaporative or Steam Technology

Evaporative and steam humidifiers are very different technologies. As their names imply, one uses water vapor and one uses steam. Evaporative humidifiers use the HVAC system's heat to draw through a water panel to turn the water to vapor. Steam humidifiers heat water to the boiling point to produce steam. Both technologies then use the HVAC system blower to distribute humidity through the ductwork. If a ducting system is not available, steam units can be mounted with a blower pack.

Both technologies effectively deliver the right levels of humidity throughout the home. But it is important the right product is selected to ensure consumer satisfaction. Evaporative humidification is the best choice for applications where the unit can be mounted on the duct work. They're easier to install, extremely reliable, last the life of the equipment, and offer an attractive consumer price point.

Steam products fill in the gaps where evaporative products cannot be installed or do not offer enough capacity. These gaps include lack of duct space on the plenum, attic, or crawl space locations, in-floor heat, electric strip heat, boilers, hydronic heat, and where systems experience short run times like milder climates.

Humidification for Non-Ducted Systems

about

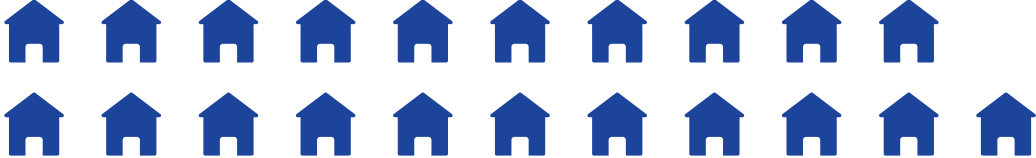
21 

million homes are heated without ductwork.
Differentiate your business by solving this problem in your region.

Dry air is not only unhealthy, it's uncomfortable. In addition to accelerating the transmission of airborne viruses, it can aggravate asthma and allergy symptoms, and cause wood floors and furnishings to warp. Maintaining healthy levels of humidity helps to reduce these symptoms and protect the wood in your home.

Our humidifiers provide whole-home humidification for every application. We utilize steam and evaporative technologies in our products to provide you with effective options based on such variables as square footage and existing heating/cooling system. When it comes to the 21 million homes with non-ducted systems such as boilers, mini-splits, and radiant heat, we have what you need to provide Healthy Air through humidity control to more customers.

Evaporative Humidification

Residential evaporative humidifiers are generally designed in one of two styles: bypass or fan powered. The difference is how the air is delivered to the humidifier. In the bypass design, air is passed from the supply to the return. In the powered version, a fan blows air through the unit.



Fan-Powered

Bypass

Self-Contained

Easy to Maintain

It only takes a couple minutes to replace the water panel. For best performance, it's recommended the water panel be replaced annually.*

Long Life — Trouble Free

AprilAire Evaporative Humidifiers were designed to ensure minimum maintenance and trouble-free performance. All humidifier housing parts that come in contact with water are non-metal so they will never rust or corrode. Neither heat nor water will affect them under normal operating conditions.

Periodic preventative maintenance should be conducted on the distribution tray which is directly on top of the water panel. It should be inspected annually and cleaned of excess mineral deposits. Yearly inspection of the feed tube and periodic cleaning of the orifice is all that's needed to extend the life of the humidifier. If properly maintained, an evaporative humidifier will last longer than the HVAC system on which it is installed.

Ease of Installation

Most models of evaporative humidifiers mount directly onto the plenum of the HVAC system.

The Model 300 is designed for use in homes without central forced air systems and mounts between or below floor joists, delivering healthy humidified air into the living space.

Convenience

The components that require significant cleaning can simply be replaced. Replacing a water panel is much easier and more cost effective than spending hours cleaning portable units. Many contractors will replace the water panel as part of a scheduled maintenance program for the HVAC system. This is a great way to grow revenue.

Capacity

Evaporative humidifiers efficiently use the HVAC system to operate. The plenum temperature and blower from the furnace or air handler are used to produce humidity. The amount of time the plenum temperature is raised from a heat call is variable and so is the actual temperature; with heat pumps around 90°F and gas furnaces at 120°F. The HVAC blower is required to humidify, however, a raised plenum temperature from a heat call is not required if plumbed to hot water. These variables are all considered in the capacity chart on the specifications page (see back cover).

*Twice per humidifier season for the Model 400

Sequence of Operation

The water in evaporative humidifiers flows to the distribution tray located at the top of the humidifier. The water is uniformly distributed across the width of the tray and through a scientifically designed system of outlets. It flows by gravity over the water panel evaporator. Dry, hot air from the HVAC system is moved through the moisture-laden water panel evaporator. Natural evaporation takes place, and the now-humidified air carrying moisture in vapor form (nature's own way) is circulated throughout the home.

The correct water flow is determined by an orifice. When the humidifier is operating, the water that is not evaporated passes on to the drain (in the drain-equipped models). Trouble-causing minerals that are the inevitable result of water evaporation are either trapped by the water panel, contained in the scale control insert or flushed down the drain.

Duct Location (for Models 400, 500, 600, 700)

Fan-powered humidifiers are designed to be installed on the warm air supply plenum of forced air furnaces or heat pumps. If there is no space on the warm air supply plenum for the humidifier, the unit may be installed on the cold air return duct; however, you will need to supply the humidifier with hot water because the hot water will be the only heat source.

Bypass humidifiers are designed to be installed on the warm air supply plenum or cold air return of a forced air upflow, or downflow, horizontal furnace or heat pump. The humidifier is then ducted to the opposite side return or supply. The operation is the same regardless of which duct is used for the installation. Correct operation requires a minimum static pressure of 0.2" w.c.

Water Quality

Evaporative humidifiers will perform with hard or soft water. It's recommended 140°F water be used for optimum performance; therefore, any time the humidifier will operate without a call for heat, you must plumb to hot water.

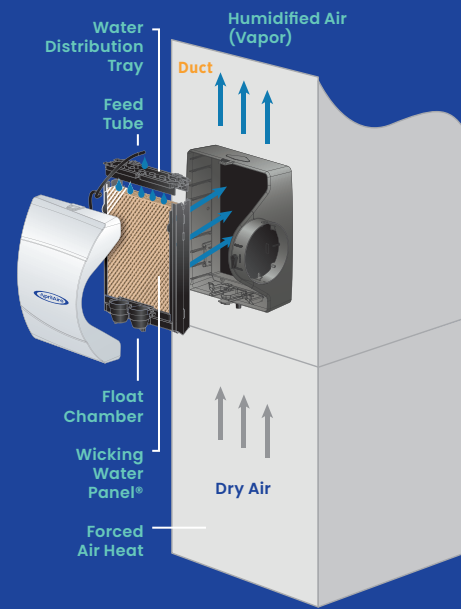

Upflow (Power)

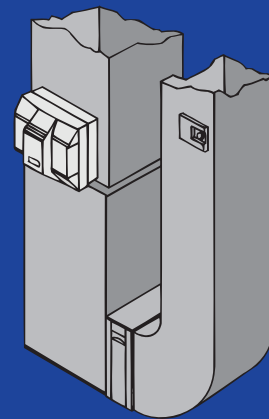

Horizontal (Bypass)

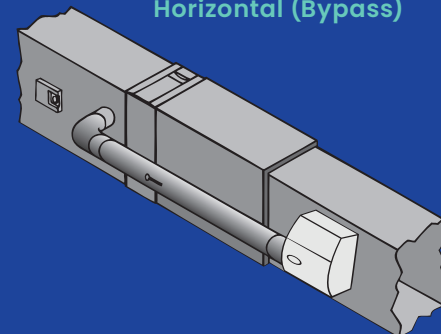

Steam Humidification

AprilAire Steam Humidifiers are simple to install, operate, and maintain. AprilAire steam units are offered with two operational technologies: on/off and modulation. With on/off control, the humidifier will operate at full capacity until the set point is reached. With modulating operation, the humidifier's output will vary depending on how close or far away indoor RH levels are from the desired set point.

Simple to Service and Maintain

To create steam, water needs to be heated. With electrode technology, electrical current flows between two submerged electrodes. Resistance of the water to the electric current heats the water. The submerged electrodes are found in a replaceable canister. At the end of a humidifier season, the canister should be replaced. The electrode wires should be replaced at least every three years, or sooner if they become loose or damaged. No cleaning, no scrubbing, simply replace the canister and you're ready for the next humidifier season.

Limited Water Quality Concerns

When water is heated, it boils and produces steam leaving behind deposits and minerals. Electrode technology requires impurities in the water to promote the flow of current. For this reason, water filtration is not required with electrode technology, minimizing the complexity of the installation and on-going operating costs. The unit will operate with water hardness between 3 and 36 grains—a very wide range. If reverse osmosis or deionized water is present, plumb unit to water line prior to those devices.

Simple Unit Selection

The AprilAire Steam Humidifier uses electricity to boil the water. The control algorithm in the unit manages the water level to ensure either 11.5 or 16.0 amps of current is maintained while operating, depending on installation. The 11.5/16.0 amps is the same if it's

installed with 240V or 120V, leading to an increase in steam produced based on the voltage that is selected. This flexibility allows the same unit to be used for small and large homes.

Easy to Install

Included with every AprilAire Steam Humidifier is a remote mounting kit, automatic digital humidifier control, dispersion tube, drain tube, saddle valve, and mounting hardware. All parts required for a remote or duct install are included with the unit. Simply mount the unit, connect water feed and drain lines, and mount the dispersion tube in the duct and you're done.

Capacity

The AprilAire Model 800 Steam Humidifier can add 11.5 to 34.6 gallons per day (GPD) of moisture to the air. Increased voltage leads to greater humidity capacity and 240 volts is recommended to achieve maximum potential.

Sequence of Operation

AprilAire Steam Humidifiers deliver humidity to a home's conditioned space through the HVAC system ductwork. The humidifier operates utilizing electrode technology: current flowing between two electrodes in the disposable steam canister boils water to generate steam. Drain and fill valves in the humidifier work together to maintain the correct water level in the canister to satisfy the demand for humidity based on the electrical conductivity of the water.

Dispersion Technology

The proper speed and method of dispersing steam into the air stream is essential to avoid rusting ducts. AprilAire Steam Humidifiers quickly deliver the hottest, driest steam to the air by utilizing “dispersion tubelets.” This technology prevents excess water from forming in the duct work when the dispersion tube is properly installed. Refer to the chart at the right for steam absorption distances within ductwork.

Water Conductivity

Our steam humidifiers are optimized to work with most water conditions and related conductivity and hardness – even artificially softened water. We also offer a low conductive (LC) canister for use in water that is by nature extremely soft – such as homes fed from a reservoir water source. The Model 80LC is also recommended in all 120 VAC installations. The Model 80LC canister is recommended in all 120 VAC applications but should not be used in homes where the water is artificially softened with a water softener. Use a Model 80 canister in those applications.



Model 800 Steam Humidifier

ABSORPTION DISTANCE (Minimum distance from dispersion tube downstream to any obstruction or bend in duct)					
Humidifier Output (gal/day)	Airflow Velocity*	75°F & 30% RH Setpoint	70°F & 45% RH Setpoint	65°F & 45% RH Setpoint	45°F & 45% RH Setpoint
Up to 16.0	300 fpm	13"	19"	23"	30"
	600 fpm	6"	10"	12"	18"
	1200 fpm	3"	5"	6"	13"
	1800 fpm	2"	3"	4"	10"
20.5-25.0	300 fpm	15"	23"	28"	45"
	600 fpm	6"	12"	13"	26"
	1200 fpm	5"	6"	7"	19"
	1800 fpm	3"	4"	5"	16"
25.0-35.0	300 fpm	24"	31"	36"	60"
	600 fpm	17"	22"	26"	48"
	1200 fpm	12"	15"	18"	25"
	1800 fpm	10"	13"	15"	20"

*Velocity in feet per minute = Duct airflow volume in cubic feet per minute/duct area in square feet. Example: 1,200 cfm through 16" X 12" duct = 1,200/(12 X 16/144 sq. in./sq. ft.) = 1,200/1.333 = 900 fpm

MODEL SELECTION BASED ON WATER CONDUCTIVITY			
Conductivity	Hardness	Water Characteristic	Recommended Model Installed at 208/240VAC
75-100	0-3	Naturally Soft	Model 800LC
100-300	3-9	Naturally Soft	Model 800LC
300-500	9-15	Slightly Hard	Model 800
500-650	15-20	Moderately Hard	Model 800
650-850	20-25	Hard	Model 800
850-1250	25-36	Very Hard	Model 800
Above 1250	Above 36	Extremely Hard	Installation Not Recommended

The Model 80LC will not work with water that has been artificially softened with a water softener. The Model 800LC is recommended for any installation regardless of water quality when installed at 120 VAC.

Electrode Wires



Replaceable Canister

Canister & Electrode Wire Replacement

It is recommended the canister is replaced after every humidifier season, and the electrode wires are inspected every year, and replaced every three years unless loose or damaged. Our steam humidifiers also have a service light that will turn on when the canister should be replaced due to low conductivity.

Simple Canister Replacement:

1. Turn off power at the unit – unit will automatically drain.
2. When drain is finished, turn off electrical power to unit.
3. Remove front panel.
4. Disconnect electrode wires, water sensor and hose clamp at top of canister.
5. Replace with correct canister (see “Model Selection” chart above) and provided O-ring.
6. If electrode wires are loose, damaged or over 3 years old, disconnect them from the control board and replace with #4978.

For full maintenance instructions, please refer to the AprilAire Steam Humidifier Install & Maintenance Instructions.



Fan Pack

For homes without ductwork or where ductwork is not accessible, we offer a Fan Pack which marries with the AprilAire Steam Humidifier to provide humidity.

Applications that do not have forced air through a duct system to distribute air into the home are typically installed with the AprilAire Model 865 Ductless Humidifier with Fan Pack. The fan pack is mounted in the conditioned space and distributes the humidity into the air. Humidity levels are adjusted in the living space by the Model 65 Humidifier Control.

Easy Installs, Versatile Applications



Sizing

Sizing a humidifier is similar to sizing a heating and cooling system. The humidifier capacity required will be determined by various factors, including: the volume of area being humidified, the air change rate (infiltration or ventilation), and humidification load.

Volume of Humidified Area

The volume can be determined from a floor plan or from measurements taken within the home. It's important to determine the volume, not just the square feet. Care should be taken to determine ceiling height or any open space such as vaulted ceilings. If the basement is heated and ventilated, its volume should also be included.

Air Change Rate (Infiltration or Ventilation)

The amount of infiltration is usually calculated when computing the heating and cooling load.

AHRI defines structure types as follows:

- **Tight construction:** ½ air changes per hour of air infiltration, well insulated with vapor retarders, tight storm doors, windows with weather stripping.
- **Average construction:** 1 air change per hour of air infiltration, insulated with vapor retarders, loose storm doors and windows, dampered fireplace.
- **Loose construction:** 1½ air changes per hour of air infiltration, usually built before 1930 with little or no insulation, no storm doors, no insulated windows, no weather stripping, no vapor retarders, undampered fireplace.

AHRI has also established a standard guideline for determining capacity ratings, which provides a means of comparing product specifications. Capacity is determined by the output of the device as if it operated 24 hours per day (AHRI Guideline F 2008).



Other Considerations

The typical family of four will generate two gallons per day of moisture from internal sources such as cooking, showering and breathing. This amount can be subtracted when sizing a humidifier.



Designed & Assembled in the USA
Using U.S. and Global Components

HUMIDIFIER SIZING GUIDELINES GPD NEEDED PER SQUARE FOOT** BASED ON BUILDING STRUCTURE TIGHTNESS							
STRUCTURE TIGHTNESS	VOLUME OF BUILDING (FT ³)						
	8000	12000	16000	20000	24000	32000	40000
	BUILDING FLOOR AREA (FT ²) WITH 8 FT CEILINGS						
	1000 Ft ²	1500 Ft ²	2000 Ft ²	2500 Ft ²	3000 Ft ²	4000 Ft ²	5000 Ft ²
Tight	3.3 GPD	5.0 GPD	6.7 GPD	8.3 GPD	10.0 GPD	13.4 GPD	16.7 GPD
Average	6.7 GPD	10.0 GPD	13.4 GPD	16.7 GPD	20.0 GPD	26.7 GPD	33.4 GPD
Loose	10.0 GPD	15.0 GPD	20.0 GPD	25.0 GPD	30.1 GPD	40.1 GPD	50.1 GPD

Humidifier Controls

Digital Control

AprilAire Digital Humidistats are simple to read and keep the homeowner informed on the status of the humidifier. The control has lights to indicate when the water panel should be replaced and when to contact you for service.



Controlling Humidity

Determining the correct level of indoor relative humidity requires consideration of more than one variable. While it's best for a home's occupants to have relative humidity set between 40-60%, the overall tightness of the home can limit that. Condensation or fogging on windows is usually a sign that indoor RH levels are too high based on their surface temperature. This same condensation could also be taking place inside walls and other areas vulnerable to damage from excessive moisture.

The best humidity control plan will set safe limits for indoor RH that achieve maximum benefits without damage or condensation. The table to the right shows the recommended indoor RH based on outdoor temperature.

RECOMMENDED INDOOR HUMIDITY LEVELS	
Outdoor Temperature (°F)	Recommended Humidity (%)
+40	45%
+30	40%
+20	35%
+10	30%
0	25%
-10	20%
-20	15%

Continuous Automatic Control

AprilAire humidifiers feature Automatic Humidifier Control, which monitors outdoor temperature and automatically adjusts the humidifier so that it provides the optimal RH level to the home. It can react to temperature changes quickly, which means it can provide up to 50% more moisture than other humidifier controls.

Modulating Humidifier Control Operation

To precisely adjust the steam output of the Model 801, a modulating control must be used. When it detects RH below the set point, the humidifier energizes the electrodes in the canister to provide steam. Humidification may be required when there

is no need for heating or cooling. For this to occur, the HVAC system's blower must be activated before steam is introduced to the duct. If the modulating control does not activate the HVAC system on a call for humidity, we recommend using a blower activation relay. The modulating control will vary the steam humidifier's output based on the difference between the set point and actual RH. The modulating control sends a proportional signal to the steam humidifier providing precise control of the living space humidity. Humidity can also be distributed directly into the living space via a Fan Pack. See Models 865 and 866.

Refer to the Model 866 operation and specifications for more detail.



Humidity Control

Humidifiers—Part of the AprilAire Healthy Air System

HUMIDIFIERS	TYPE OF HUMIDIFICATION	UNIT SIZE WIDTH X HEIGHT X DEPTH	PLENUM OPENING	CAPACITY GPD (GALLONS PER DAY)	ELECTRICAL DATA	WATER PANEL/ CANISTER
<p>#800 #801</p>	<p>Steam</p> <p>For larger homes and applications when evaporative units are less practical (attics, crawl spaces, closets, milder winter climates, non-forced air-heating source).</p>	10 1/8" x 20 7/8" x 7 1/8"	-	11.5 GPD 16.0 GPD 20.5 GPD	120V 60HZ 11.5 AMP 120V 60HZ 16.0 AMP 208V 60HZ 11.5 AMP	80††
<p>#865 #866***</p>	<p>Ductless Steam</p> <p>Includes the Model 800, Fan Pack, Model 65 Control, and Model 4028 Drain Trap. For homes without forced-air heating systems.</p>	<p>Fan Pack: 14" x 6 29/32" x 3 15/16"</p> <p>Finished Grille: 16 3/16" x 9" x 1 3/32"</p>	-	30.0 GPD 23.3 GPD 34.6 GPD	208V 60HZ 16.0 AMP 240V 60HZ 11.5 AMP 240V 60HZ 16.0 AMP	
<p>#700* #700M**</p>	<p>Fan Powered Evaporative</p> <p>Built-in fan that pulls heated air directly from the furnace.</p>	15 29/32" x 18" x 10 11/32"	W: 14 3/4" H: 14 31/100"	18 GPD	120V 60HZ 0.8 AMP	35
<p>#600* #600M**</p>	<p>Large Bypass Evaporative</p> <p>Uses the furnace blower to move air through a Water Panel.</p>	15 3/8" x 15 3/4" x 10 1/4" 6" dia. round opening	W: 10" H: 12 3/4"	17 GPD	24V 60HZ 0.5 AMP	35
<p>#500* #500M**</p>	<p>Small Bypass Evaporative</p> <p>Designed for smaller homes.</p>	15 5/8" x 13" x 10 1/4" 6" dia. round opening	W: 9 1/2" H: 9 1/2"	12 GPD	24V 60HZ 0.5 AMP	10
<p>#400* #400M**</p>	<p>Water Saver Bypass Evaporative</p> <p>Uses 100% of water and evaporative technology that eliminates the need for a drain. Conserves water.</p>	15 3/8" x 15 3/4" x 10 1/4"* 6" dia. round opening See note on heat pumps†	W: 10" H: 12 3/4"	17 GPD	24V 60HZ 0.5 AMP	45
<p>#300</p>	<p>Self-Contained Evaporative</p> <p>For boilers, mini-splits, radiant heat, and ductless systems.</p>	14 3/8" x 12 1/2" x 22 3/32"	-	13 GPD	120V 60HZ 0.7 AMP	35

* Automatic Digital Control (shown)

** Manual Control - For those rare occurrences where an automatic control is not practical, AprilAire offers the same great humidifiers with a mechanical control.

*** 801 & 866 Modulating Steam Humidifier - For precise RH control. Controls are sold separately.

† Heat Pumps - Model 400 can be installed in heat pump applications. However, due to the fact that heat pumps deliver lower temperature air to the home than gas furnaces, evaporation will be approximately 60% of rated capacity. (With other AprilAire models, hot water can be used instead of cold to maximize evaporation. However, due to the nature of the wicking water panel in Model 400, hot water provides less benefits). As such, your dealer will need to take the size and age of your home into consideration to ensure the Model 400 will provide satisfactory comfort and protection through adequate humidification.

†† Model 800LC available with 80LC canister for less conductive water 75-300µS/cm and 120VAC applications.

‡ AHRI Air Conditioning, Heating, and Refrigeration Institute GPD = Gallons Per Day Guideline F

A family of 4 will add 2 gallons of humidity per day through everyday activities like breathing, cooking, bathing and washing. Evaporative capacities assume blower is active 100% of the time, plenum temperature is at 12° F and water is cold.

Bypass Humidifiers - Can be installed on the supply or return plenum.

Water Usage Rate - Model 300 is 6 gph (gph=gallons per hour); Models 500, 600 and 700 are 3 gph; Model 400 is 0.7 gph; Model 800 is 0.6 to 1.8 gph depending on voltage, amp draw and water quality.

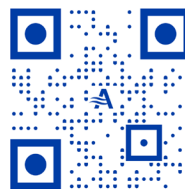

Download the AprilAire
Healthy Air App