

# PRPGE14

## PRODUCT SPECIFICATIONS

## 14 SEER GAS ELECTRIC PACKAGED UNIT

FORM NO. PRPGE14-100 (01/2017)

### REFRIGERANT SYSTEM

- Environmentally friendly R410A refrigerant
- Copper tubing with enhanced fin coils
- Internal service gauge ports
- Sleeved distributor tubes
- Microban Antimicrobial Drain Pan
- High and Low Threaded pressure switches for system protection

### HEAT EXCHANGER

- L models comply with California Energy Commission Low NOx regulations
- Aluminumized Tri-Dimple tubular heat exchanger for increased efficiency
- Pest protected flue outlet

### CABINET CONSTRUCTION

- Rounded corners for safety and an attractive, clean appearance
- One piece base design for strength and stability
- Drain ports for condensate management and coil runoff
- Low profile, with compact footprint
- Insulation to minimize heat loss plus reduce sound
- Textured pre-painted steel cabinet finish
- Superior service access to components
- Louvered coil guard protection
- One piece “no leak” top design

### BLOWER

- Insulated compartment to reduce sound
- Efficient multispeed motor for wide airflow range
- Slide out blower housing for easy service

### CONTROLS

- Solid state integrated blower control board with L.E.D. self diagnostics
- Direct spark ignition
- Color coded wiring for easy service

### INSTALLATION

- Horizontal or down discharge capable
- Utility connections on “right side”
- Tabbed duct flanges for simple duct connection

### ACCESSORIES

- Hinged roofcurb
- Lifting brackets
- LP Gas Conversion
- Internal Filter Kits



### WARRANTY

10 year limited parts and compressor warranty/lifetime heat exchanger warranty available. See limited warranty document for details.



**MODEL NUMBER GUIDE**

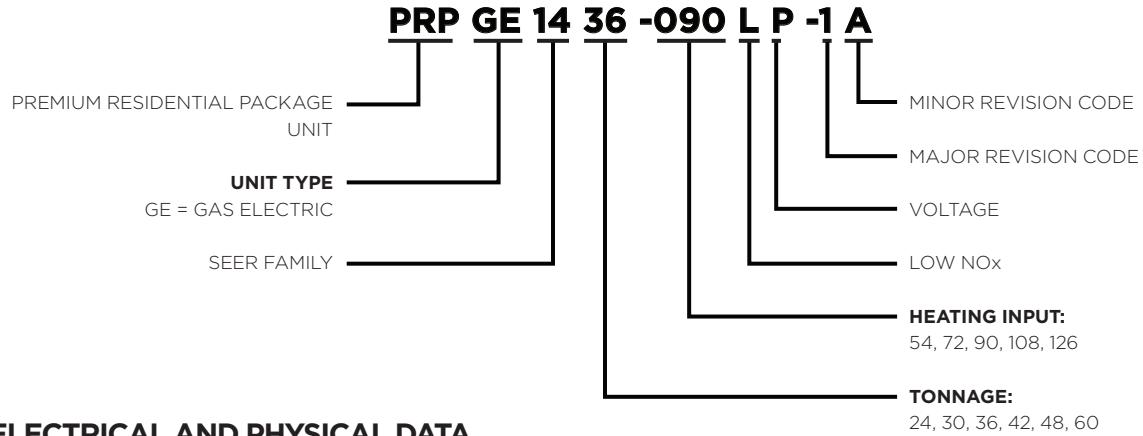

**ELECTRICAL AND PHYSICAL DATA**

Model	Voltage	Phase	Hz	Min Volts @ 60 hz	MCA	Max Fuse/HACR Breaker	Compressor		Condenser Motor		Blower Motor		Exhaust Motor		Refrig. Charge (oz.)	Weight (lbs.)	
							RLA	LRA	RLA	HP	RLA	HP	RLA	HP			
PRPGE1424-054(L)P	208-230	1	60	197	16.7	25	11.2	60.8	1.0	1/6	1.7	1/4	0.22	1/50	70	352	
PRPGE1424-072(L)P																358	
PRPGE1430-054(L)P																77	364
PRPGE1430-072(L)P																	370
PRPGE1436-054(L)P																79	377
PRPGE1436-072(L)P																	383
PRPGE1436-090(L)P																	389
PRPGE1442-072(L)P																84	454
PRPGE1442-090(L)P																	460
PRPGE1448-108(L)P																82	470
PRPGE1448-126(L)P																	476
PRPGE1460-108(L)P																125	507
PRPGE1460-126(L)P																	513

**PERFORMANCE**

MODEL	COOLING					HEATING				Sound dBA
	Rated AHRI Capacity Btuh	SEER	EER	Rated Sensible Capacity Btuh	CFM	Input BTUH	Output BTUH	Efficiency AFUE	Temp Rise Range F	
PRPGE1424-054(L)P	22,600	14.0	11.0	16,500	800	54,000	43,800	81%	30-60	78
PRPGE1424-072(L)P						72,000	58,400		40-70	
PRPGE1430-054(L)P	28,400			20,700	1000	54,000	43,800		30-60	
PRPGE1430-072(L)P						72,000	58,400		40-70	
PRPGE1436-054(L)P	34,000			25,800	1200	54,000	43,800		30-60	
PRPGE1436-072(L)P						72,000	58,400		35-65	
PRPGE1436-090(L)P						90,000	72,900		40-70	
PRPGE1442-072(L)P	40,000			30,000	1400	72,000	58,400		30-60	
PRPGE1442-090(L)P						90,000	72,900		40-70	
PRPGE1448-108(L)P	46,000			35,000	1600	108,000	87,500		40-70	
PRPGE1448-126(L)P						126,000	102,100		45-75	
PRPGE1460-108(L)P	57,000			41,600	1800	108,000	87,500		40-70	
PRPGE1460-126(L)P						126,000	102,100		45-75	

\*Certified in accordance with Unitary Air Conditioner Certification Program, which is based on AHRI Standard 210/240

**BLOWER PERFORMANCE**

Model	Blower Tap	CFM @ ext. Static Pressure in in. wc without filter, dry coil							
		0.1	0.2	0.3	0.4	0.5	0.6	0.7	0.8
PRPGE1424 PRPGE1430	2	1350	1310	1270	1210	1140	1080	1020	950
	3	1110	1080	1050	1000	970	920	870	800
	4	970	950	920	890	850	820	770	710
	5	840	820	800	770	750	720	680	620
PRPGE1436	2	1460	1380	1280	1190	1100	990	880	760
	3	1350	1280	1200	1130	1060	950	870	750
	4	1080	1030	960	900	830	750	700	650
PRPGE1442	2	1790	1740	1670	1590	1510	1410	1310	1210
	3	1500	1470	1430	1370	1310	1240	1140	1010
	4	1070	1050	1010	980	920	870	820	690
PRPGE1448	2	1970	1890	1790	1690	1600	1510	1400	1280
	3	1730	1690	1600	1540	1450	1360	1270	1150
	4	1520	1480	1430	1370	1310	1230	1140	1050
PRPGE1460*	1	1400	1320	1260	1200	1120	1060	980	900
	2	1920	1870	1820	1770	1720	1670	1450	1360
	3	2240	2200	2140	2100	2060	2020	1980	1950

\* TAPs 4 & 5 are for Furnace mid point rise.

**COOLING PERFORMANCE - EXTENDED RATINGS**

Outdoor Model	Indoor Temp DB/ WB °F	Outdoor Temperature - DB °F														
		65°			82°			95°			105°			115°		
		Btuh	S/T	kW	Btuh	S/T	kW	Btuh	S/T	kW	Btuh	S/T	kW	Btuh	S/T	kW
PRPGE1424	85/72	31,700	0.62	1.45	29,100	0.63	1.73	27,100	0.64	1.95	25,000	0.71	2.13	22,900	0.78	2.31
	80/67	28,600	0.68	1.45	25,700	0.71	1.72	23,600	0.73	1.98	22,200	0.78	2.15	20,900	0.84	2.33
	75/63	26,100	0.70	1.46	24,000	0.72	1.75	22,300	0.75	1.96	20,800	0.81	2.15	19,400	0.87	2.34
	75/57	22,400	1.00	1.46	20,800	1.00	1.75	19,600	1.00	1.98	19,100	1.00	2.16	18,700	1.00	2.35
PRPGE1430	85/72	36,800	0.64	1.80	34,200	0.65	2.11	32,200	0.66	2.35	29,800	0.72	2.61	27,300	0.77	2.87
	80/67	33,100	0.72	1.78	31,400	0.72	2.07	28,900	0.73	2.34	26,900	0.78	2.60	24,800	0.84	2.87
	75/63	30,000	0.76	1.78	28,200	0.75	2.09	26,800	0.75	2.34	25,100	0.81	2.61	23,300	0.88	2.88
	75/57	27,500	1.00	1.79	25,000	1.00	2.11	23,200	1.00	2.35	22,900	1.00	2.61	22,600	1.00	2.87
PRPGE1436	85/72	45,000	0.68	2.20	41,300	0.67	2.58	38,400	0.67	2.87	36,100	0.71	3.19	33,700	0.76	3.50
	80/67	41,200	0.73	2.20	37,400	0.73	2.53	34,500	0.76	2.86	32,800	0.79	3.18	31,100	0.82	3.50
	75/63	38,500	0.75	2.19	35,300	0.78	2.58	32,900	0.80	2.87	31,000	0.83	3.18	29,100	0.85	3.49
	75/57	35,500	1.00	2.19	33,000	1.00	2.57	31,000	1.00	2.87	29,500	1.00	3.18	27,900	1.00	3.49
PRPGE1442	85/72	53,600	0.63	2.66	50,200	0.65	3.14	47,600	0.67	3.51	43,600	0.73	3.84	39,500	0.79	4.18
	80/67	50,200	0.69	2.65	46,000	0.73	3.08	42,700	0.75	3.50	39,500	0.81	3.84	36,300	0.87	4.19
	75/63	47,200	0.73	2.64	42,800	0.76	3.10	39,500	0.79	3.45	36,600	0.84	3.82	33,800	0.89	4.20
	75/57	42,800	1.00	2.63	38,500	1.00	3.09	35,300	1.00	3.44	34,000	1.00	3.82	32,700	1.00	4.20
PRPGE1448	85/72	64,900	0.63	3.15	58,200	0.66	3.63	53,100	0.69	3.99	48,600	0.74	4.38	44,100	0.78	4.76
	80/67	59,200	0.71	3.04	52,300	0.73	3.52	47,500	0.76	3.97	44,100	0.81	4.36	40,800	0.87	4.76
	75/63	53,200	0.74	3.02	47,400	0.78	3.51	42,900	0.81	3.89	40,500	0.85	4.32	38,000	0.89	4.75
	75/57	46,500	1.00	2.99	42,100	1.00	3.49	38,700	1.00	3.87	37,800	1.00	4.31	36,800	1.00	4.75
PRPGE1460	85/72	70,300	0.63	3.50	66,100	0.64	4.19	62,800	0.65	4.72	59,100	0.70	5.27	55,500	0.76	5.82
	80/67	65,700	0.69	3.47	61,000	0.71	4.08	57,400	0.73	4.69	54,300	0.78	5.24	51,200	0.83	5.78
	75/63	61,400	0.72	3.45	56,300	0.74	4.12	52,300	0.76	4.63	50,200	0.80	5.19	48,000	0.85	5.75
	75/57	54,500	1.00	3.42	50,100	1.00	4.09	46,700	1.00	4.61	46,300	1.00	5.17	45,900	1.00	5.73

**DIMENSIONS (IN.)**

Model	A	B	C	D	E	F	G	H	J
PRPGE1424	36.82	46.77	13.33	13.31	5.86	16.75	14	28.14	22.14
PRPGE1430									
PRPGE1436									
PRPGE1442	40.88	55.27	18.14	18.14	4.67	19.75	19.5	32.14	26.14
PRPGE1448									
PRPGE1460									

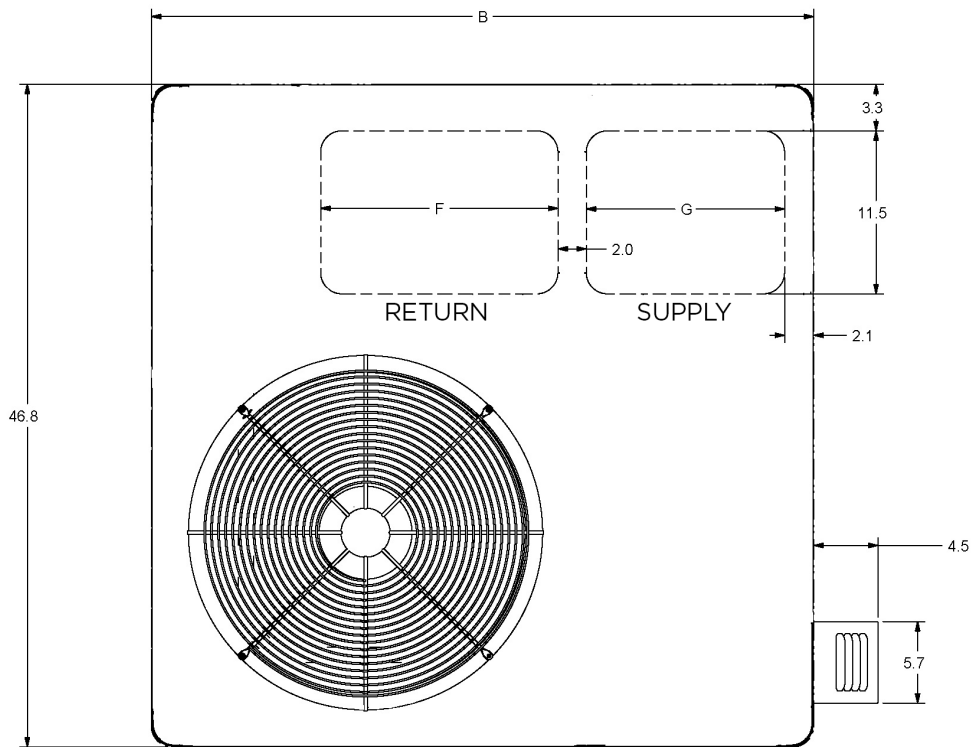
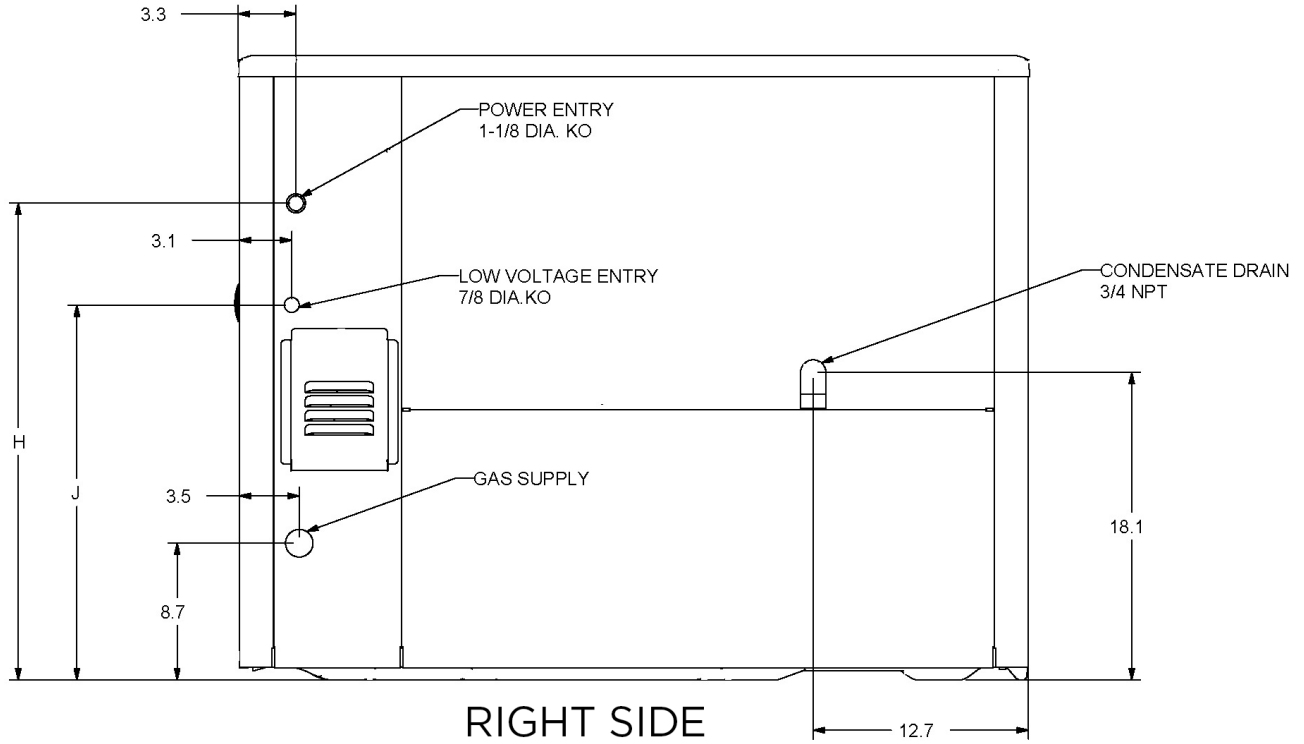

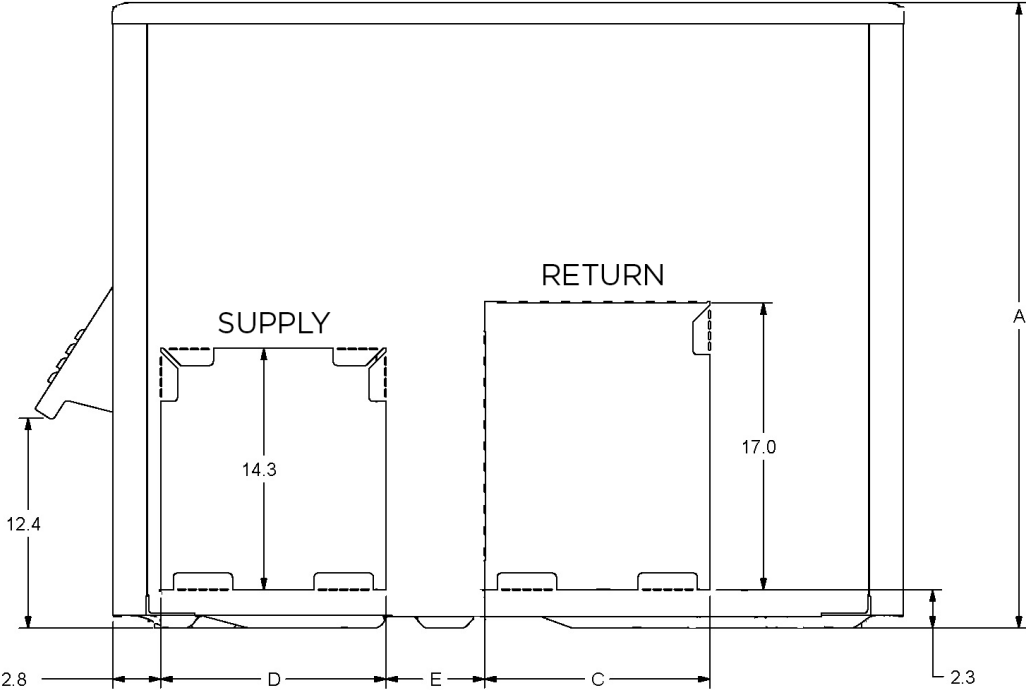

**ROOF CURB DIMENSIONS**

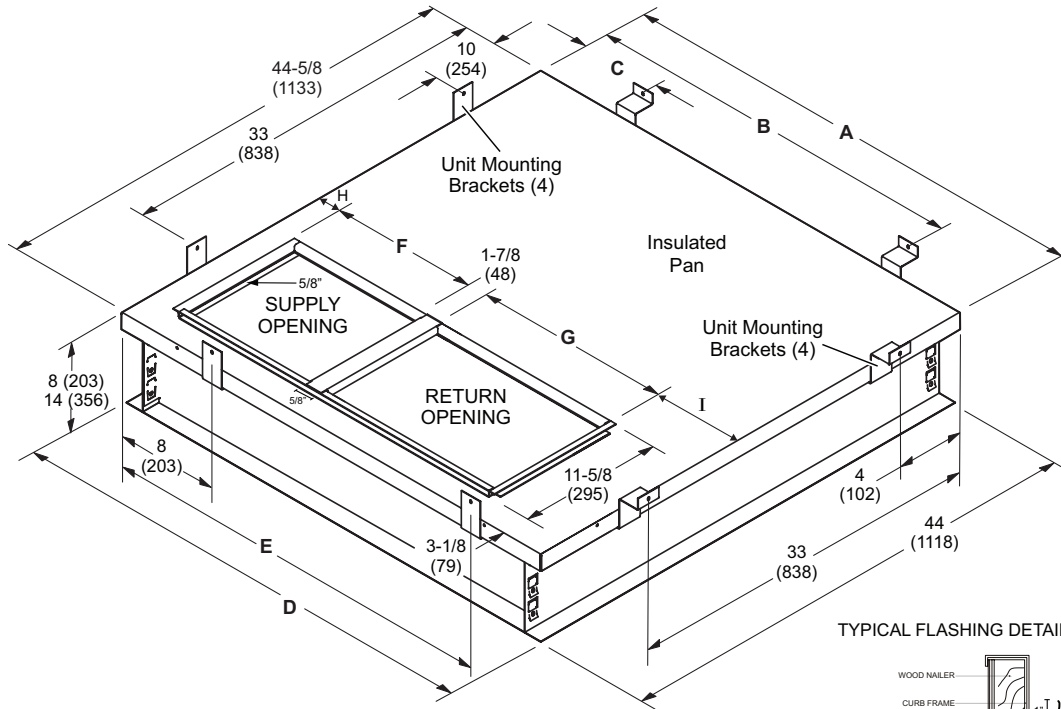

NOTE - Roof deck may be omitted within confines of curb.

TYPICAL FLASHING DETAIL

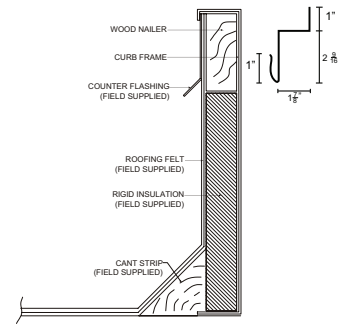

Usage	A		B		C		D		E	
	in.	mm	in.	mm	in.	mm	in.	mm	in.	mm
24, 36	44-5/8	1133	43	1092	18	457	44	1118	37	940
48, 60	53-1/8	1349	51	1295	24	610	52-1/2	1334	41	1041
Usage	F		G		H		I			
	in.	mm	in.	mm	in.	mm	in.	mm		
24, 36	16.75	356	14	425	2	51	9-3/4	248		
48, 60	19.75	495	19.50	502	2	51	10	254		

**ACCESSORIES**

Description	Where Used	Kit Number
Compressor Crankcase Heater	All	11X27
Compressor Hard Start Kit	24, 30, 36,60	10J42
Compressor Hard Start Kit	42,48	88M91
Compressor Timed-Off Control	All	47J27
Down Flow Conversion - ACONVR836	24, 30, 36	1.851401
Down Flow Conversion - ACONVR837	42,48,60	1.851402
Drain pan overflow switch	All	11U75
Filter Rack Kit	24, 30, 36	11U73
Filter Rack Kit	42,48,60	11U74
Lifting Brackets	All	11U76
LPG/Propane Conversion Kit	All	11U77
Roof Curb	24, 30, 36	11U78
Roof Curb	42,48,60	11U79
Sideflow Rect. to 14" Rounds Duct Adapter (Qty 25 sets)	24, 30, 36	R104617-01
	42, 48, 60	R104618-01
8" Height Full Perimeter Curb	24, 30, 36	14W71
8" Height Full Perimeter Curb	42, 48, 60	14W72
14" Height Full Perimeter Curb	24, 30, 36	14V68
14" Height Full Perimeter Curb	42, 48, 60	14V69



1-800-448-5872

All specifications and illustrations subject to change without notice and without incurring obligations.