



COMMERCIAL FABRICATION DIVISION

www.herculesIndustries.com

5050 Florence St. Denver Colorado 80238

Tel. 303 388-899 Fax. 303 388-8301

Toll Free. 1 800 870-4305

HERCULES HOLLOW TURN VANE & RAIL

LENGTH	GAUGE	PROD#	DESCRIP.	WT / FT
10'	24	2HTV	2" Turn Vane	.59
10'	22	2SR	Rail	.5

MATERIAL: GALVANIZED STEEL ASTM-A 653-00

HOLLOW TURN VANE

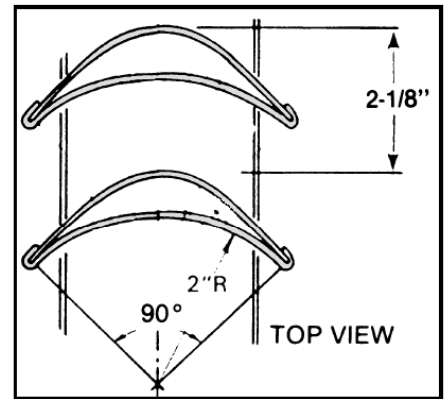

RAIL

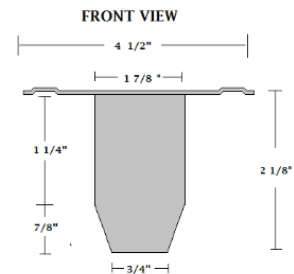
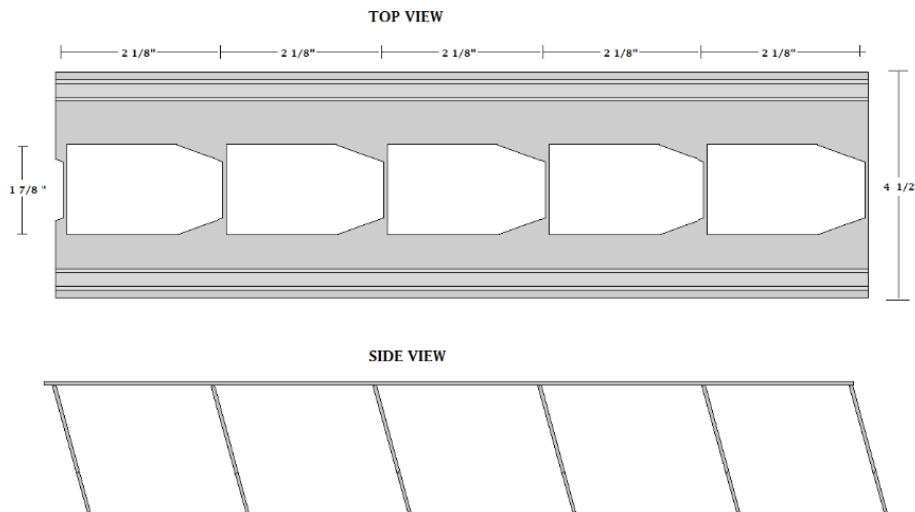

* All gauges and reinforcements are in compliance with 2005 SMACNA standards for duct fabrication.

