

# Installation Instructions & Owner's Manual



This symbol on the product means the product is listed by Underwriters Laboratories, Inc.

## **ULTRA-ZONE®** ELECTRONIC STEAM UNIT - POWER HUMIDIFIER MODELS S2000 AND S2020

FOR GAS OR OIL FORCED AIR FURNACES, HEAT PUMPS AND ELECTRIC FURNACES

The Ultra-Zone Residential Power Humidifier you have purchased has been designed to be simple to Install, Operate and Maintain.

**Read this manual before you install the Humidifier.**

Familiarizing yourself with the items listed in Figures 1 and 2 will assist you in installing and maintaining your Steam Power Humidifier. This product should be installed according to local and national codes and standards.

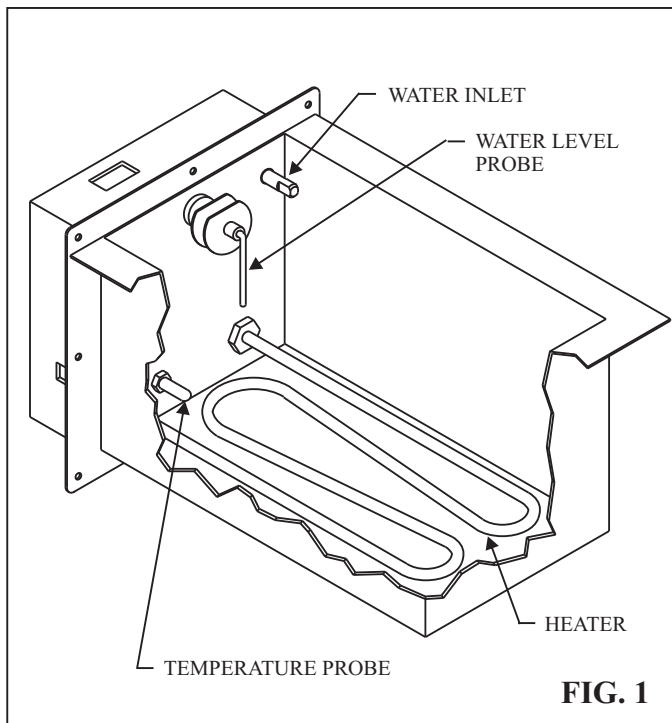

**FIG. 1**

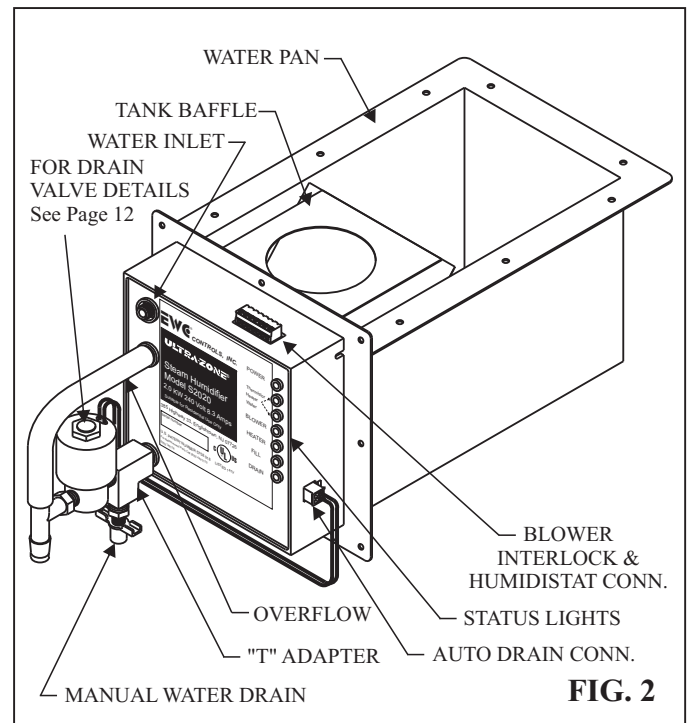

**FIG. 2**

### Parts included in the Steam Humidifier package are:

1. Self Piercing Saddle Valve
2. Installation Instructions and Owners Manual
3. Mounting Templates x2
4. Installation Hardware package
5. Insulation and tape
6. Automatic Drain Assembly
7. Humidistat - Model #062000 or 072000
8. 1/2" I.D. Drain Hose-8 FT.
9. Anode #Z100

### Options and additional parts recommended:

1. Water Hammer Arrester #WH 100
2. Anode #Z100
3. Decorative Under Duct Cover # SC100
4. Gasket Material to seal flanges (field provided)
5. Model APD Current Sensing Switch, Sail Switch or other Airflow Proving Device.
6. WFA-195 Water Filter Assembly

# SIMPLIFIED INSTALLATION INSTRUCTIONS

1. Insulate the water reservoir. See figure 3.
2. Select the mounting location on the duct and tape on the mounting template.
3. Drill the (8) 1/8" mountings holes.
4. Cut out the humidifier opening in the duct.
5. Insert the humidifier into the opening and screw in place.

6. Flush and connect the water line.
7. Connect the drain line.
8. Make 24 VAC electrical connections to achieve fan operation and interlock circuit.
9. Install and connect the humidistat.
10. Plug power cord into a grounded dedicated 120 VAC, 20 amp outlet for S2000 (240 VAC, 15 amp for S2020).

## DETAILED INSTALLATION INSTRUCTIONS

### 1. INSULATE WATER TANK RESERVOIR

With insulation foil side down, remove adhesive backing. Align humidifier so that front side of unit meets long edge of insulation. Fold insulation up onto sides of humidifier and press firmly. Apply 5 continuous strips from the tape provided to seal the foil as shown. The tape will prevent the sharp duct edges from damaging the foil. Use additional foil tape to repair damage to the foil. **The Insulation MUST be applied to the tank regardless of the mounting location.**

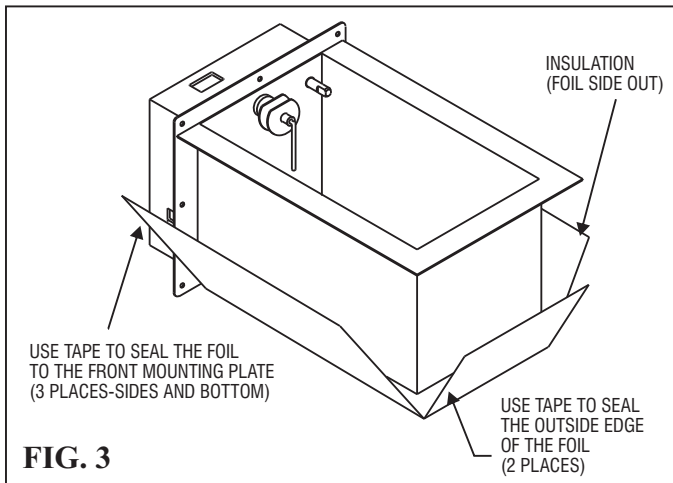

### 2. LOCATION-LOCATION - Required Criteria

**DO NOT INSTALL this unit in an attic period. Do Not Install this unit in any area that may fall below 35 degrees F. Doing so will void your warranty!** The steam humidifier can be installed in either the warm air supply or the cold air return ducts; however the **preferred** location would be in the warm air supply duct of the system. This humidifier does not require warm air to evaporate the water in order to provide humidity, but it will operate more efficiently in the warm air duct and condensation is less likely to occur on the surrounding cold surfaces. Efficiency is lost in a return air duct location.

When selecting a location on the duct, be certain that there is enough room in the duct for the water reservoir. There should be at least five (5) inches above the reservoir and the reservoir should not occupy more than about 25 percent of the duct space. If this criteria can not be met, you should install the unit under the duct by means of the tank flange. **See page 6.**

**If a suitable means of gravity draining the unit is not available or cannot be provided, the unit will work with the drain valve electrically disconnected. Call the Technical Support Hotline for Instructions.**

**It is highly recommended but not required that the use of Fiberglass duct-board with this product includes an anti-microbial treatment.**

### 3. WEIGHT - Required Criteria

**Providing Adequate Structural Support for this unit is the responsibility of the Installer. It is recommended to reinforce the cut openings with folded lengths of sheet-metal to provide rigidity to the duct opening. Now the screws must pass through 3 layers of metal when inserted.**

**DO NOT install this unit into fiberglass duct without adequate structural support!** Both models weigh approximately 9 lbs. empty and 15lbs. full of water.

### 4. MOUNTING TEMPLATE

Two mounting templates are provided. Choose the correct template for your mounting method. Tape the mounting template to the duct. The template must be leveled using the top of the cutout on the template. The template should be located so that the bottom of the reservoir cut-out is flush with the inside of the bottom of the duct for horizontal duct. Since most ducts are insulated this additional space, about one (1) inch, must be accounted for when determining the location for the bottom of the reservoir cut-out. If you are mounting it under the duct, make sure the duct is level.

### 5. DRILL HOLES AND CUT OPENINGS

Use an electric drill, with grounded power cord, to drill eight (8) mounting holes, 1/8" diameter, in the duct. These can be drilled through the template at the locations indicated on the template.

A saber saw or tin snips can be used to cut out the water reservoir opening.

Insert and/or mount the Humidifier and secure it to the duct with the provided screws.

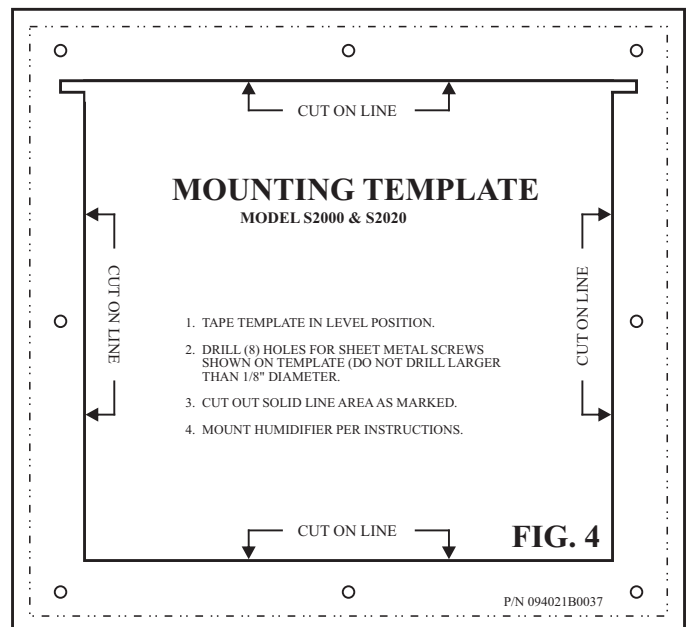

## 6. WATER SUPPLY - Required Criteria

### A. WATER SUPPLY USING THE SADDLE VALVE FURNISHED WITH UNIT. Important! See page 14.

Installation instructions for the saddle valve are printed on the plastic bag containing the saddle valve and its components. Tap into a 1/2" or 3/4" domestic cold water line. Avoid connecting to water lines from a Reverse Osmosis system or De-ionized water systems. **The supply water must read a minimum of 25 ppm in order for the Steam unit to reliably sense the water.**

**NOTE:** Never install the saddle valve on the bottom of the water pipe. Sediment in the water pipe may clog the saddle valve. **Flush the line before connecting to the unit.** When tightening the hex compression nut, tighten only enough to assure there are no leaks.

**NOTE:** Saddle valves do not meet plumbing codes in some areas. A "T" fitting with a valve may be required to meet code or, if low water pressure causes frequent water alerts on the steam humidifier. **NOTE: Flush the new water line before connecting it.**

**NOTE:** The use of City water or Municipal water is preferred. Softened water is preferred over untreated well water. **Specify the Optional WFA-195 disposable water filter for treating any water supply that is very high in mineral content.**

**NOTE:** Use a water hammer arrester (WH-100) if water spikes occur (pipes bang) during fill ups.

### B. OVERFLOW & DRAIN LINES - Required Criteria

**The use of an overflow line and drain line is always required.**

Use the supplied 1/2" ID high temperature hose. Slip the hose over the 1/2" OD "T" drain fitting and use a hose clamp to secure. **Route the hose to a suitable drain, avoiding kinks, traps and sharp objects. DO NOT route the hose above the humidifier. Failure to install all necessary drain lines may result in water leaks during normal operating conditions, and voids all warranties.**

When routing the S2000 drain hose into a condensate pump, be sure to cut the end of the hose at a sharp angle to prevent the hose from bottoming out in the pan. It could result in poor draining or no draining at all. Failure to do so may result in water backing up into the S2000 reservoir and eventual overflow. See Figure 5.

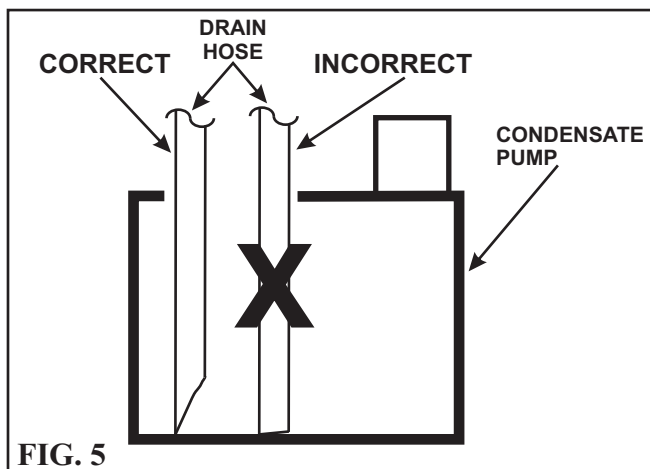

## 7. MOUNTING THE STEAM HUMIDIFIER

**Use gasket material to seal** where the front plate or tank flange contacts the duct-work. Place the humidifier reservoir into the opening in the duct and secure with eight (8) sheet metal screws.

**NOTE: If the duct-work will not support the unit in a level position with the water pan full of water, the duct-work must be reinforced. Both steam models weigh approximately 9 Lbs. empty and approximately 15 Lbs. when full of water.**

## 8. STEAM OPERATION - Required Criteria

**Because of the high output of this Humidifier, it must not be operated without the blower operating. The steam humidifier is designed to be "Dominant" over the HVAC System Blower. The "System" Blower will be operated by the humidifier when the water tank temperature reaches 170 degrees F.** A minimum of 800 cfm @ 800-900 fpm is required for proper operation of the steam humidifier. Lower velocities may result in excessive condensation inside the duct. See **Air Proving Feature** on the next column! See **Variable Speed** on Page 7.

A temperature sensor is mounted in the water reservoir of the humidifier. As the water temperature increases to about 170 degrees F, the computer closes a set of blower relay contacts to start the system fan. When the water cools to about 140 degrees F, the computer will open the relay contacts to shut off the fan. This operational sequence drastically decreases the chances of condensation occurring inside the duct-work.

## 9. WIRING THE STEAM HUMIDIFIER

**IMPORTANT: Dedicated fused circuits and outlets of the proper voltage and current ratings must be provided. Use a NEMA 5-20R receptacle for the S2000 and a NEMA 6-15R receptacle for the S2020. All wiring must conform to local and national codes. Failure to do so will void all warranties.**

**DO NOT cut off the grounded plug and/or hard wire this unit to line voltage! DO NOT use extension cords to operate this unit! Doing so will void all warranties.**

### A. INSTALLING AND WIRING THE HUMIDISTAT

A humidistat, such as the Model #072000 is required to control the Steam Humidifier. The humidistat may be installed on the wall in the living space or on the return air duct. **NOTE: Continuous fan operation should be initiated if the humidistat is installed on the return air duct!** Instructions for installation are packaged with each humidistat. Follow wiring instructions carefully!

**DO NOT connect any foreign voltage to the "H" terminals of the humidifier!** The Humidifier supplies it's own control voltage. Simply connect the two "H" terminals straight to any dry contact humidistat terminals. **If you are using a 3rd party Humidistat that has powered terminals, you must use an isolating relay to operate the Steam Humidifier. Failure to do so will result in circuit board failure and will void all warranties.**

### B. FIELD WIRING

Schematics on the following pages describe the suggested interlock wiring arrangement for different HVAC systems. Interlocking may be performed on systems that provide a 24vac NEC Class 2 terminal block for system control.

**AIR PROVING FEATURE:** The Steam Humidifier has an integrated air proving feature that allows the user to install a sail switch and/or high humidity switch in the duct and easily achieve fail safe shutdown in the event of fan/blower failure. This feature prevents the Steam Humidifier from operating unless adequate airflow is proven thereby avoiding a saturated duct condition. **WARNING: It is highly recommended to use an airflow proving device. In particular Duct-Board applications should always use an airflow proving device.**

A factory jumper wire is provided and must be removed when connecting the sail switch or other field supplied air flow proving device. Leave the jumper in place if you decide not to use the airflow proving feature.

**IMPORTANT NOTE: If the Steam Humidifier is removed and disconnected from the system, the blower interlock circuit must be restored to it's original configuration. Failure to do so may result in loss of blower operation during cooling modes!**

# CONTROL WIRING SOLUTIONS FOR VARIOUS HVAC SYSTEMS

Additional diagram shown on page 7.

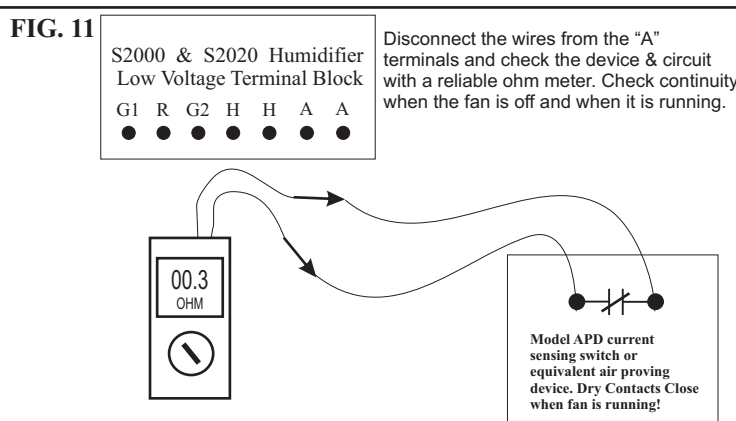
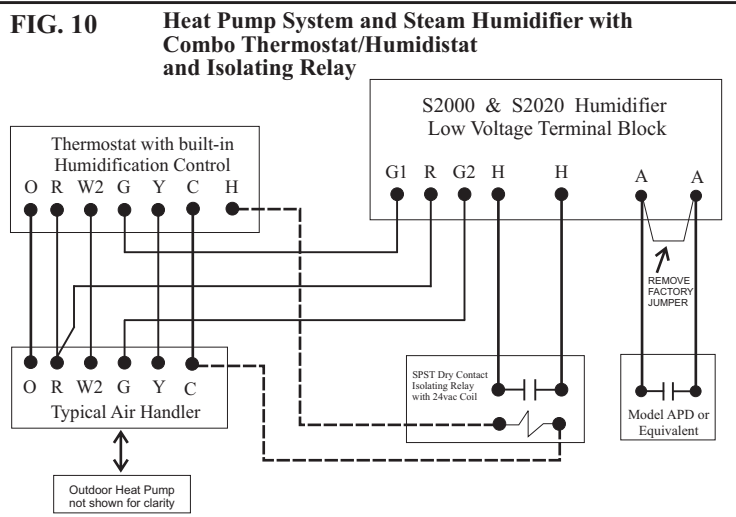
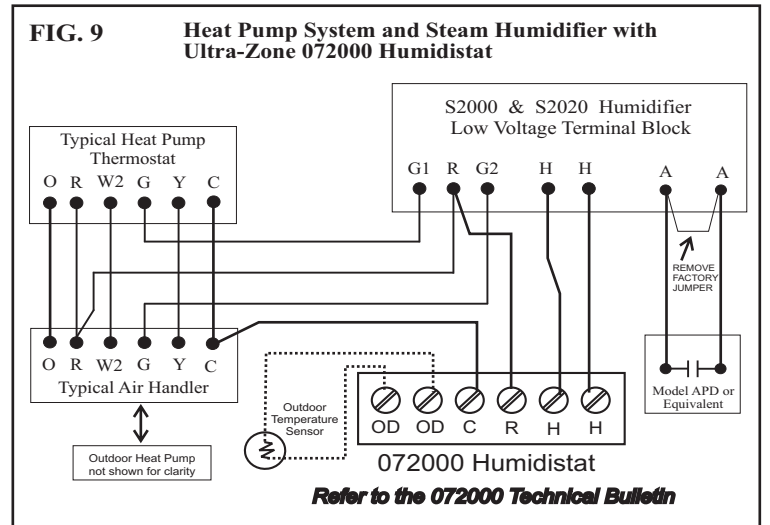
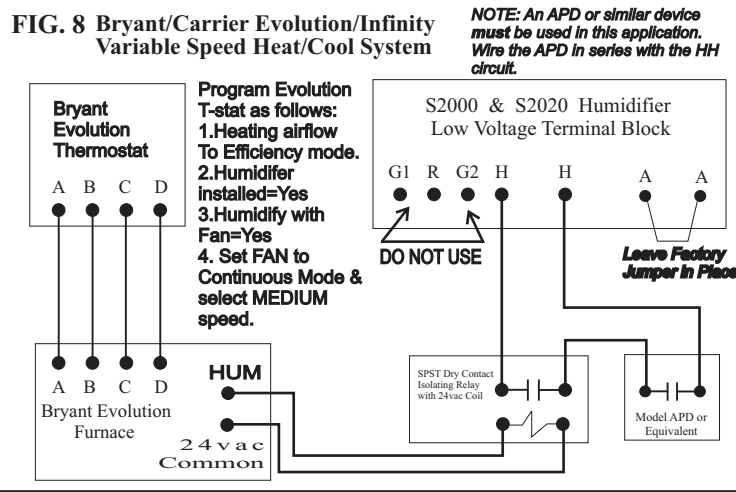
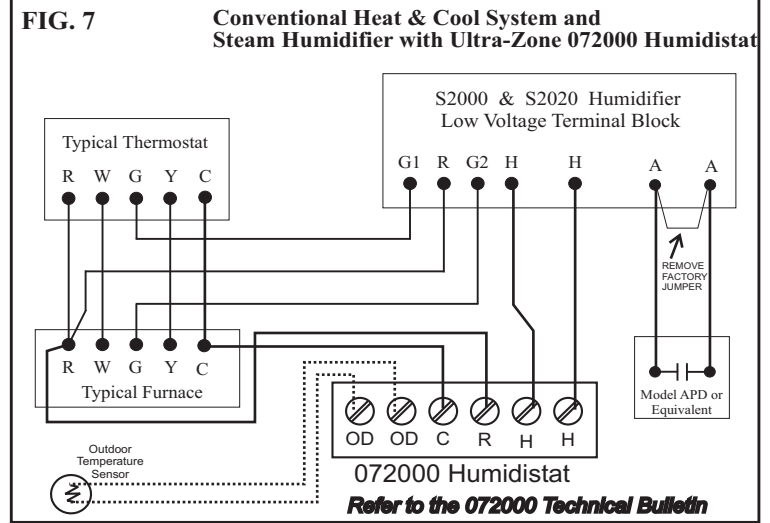
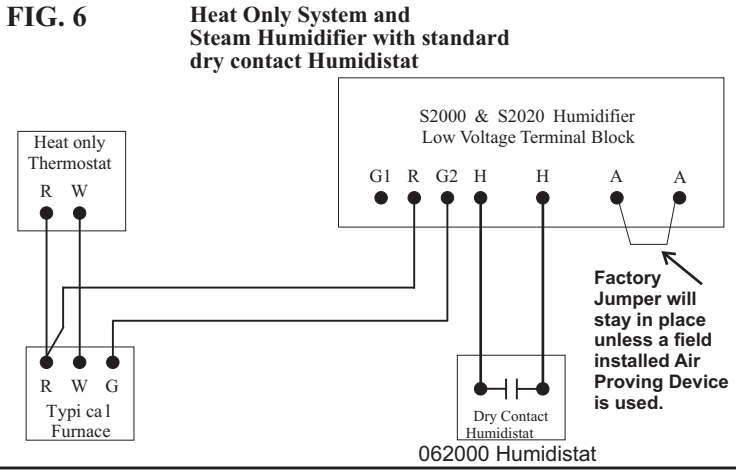

The latest improvement to the Ultra-Zone "S" series humidifiers is the new "Airflow Interlock Feature" provided on the low voltage terminal block. Due to popular demand we have made it easier for you to achieve fail safe lockout in the event the fan or blower on the HVAC system does not operate when called upon. A high humidity or airflow proving device is necessary.

You must still determine the type of proving device you want to use. **We recommend our new Model APD switch.** But then all you have to do is connect two low voltage wires from your air proving device straight to the Steam Humidifier's "A" terminals. No additional field relays or components are needed.

The Steam Humidifier monitors the airflow circuit anytime it is operating the blower on the HVAC system. If the Steam Humidifier detects a loss of airflow longer than 1 minute, it will shutdown the heating element and stop producing steam to avoid saturating the duct.

**You must test the air proving device** when you install it to make sure it will function properly. **WARNING: DO NOT** perform this test with the wires connected to the Steam Humidifier. Temporarily disconnect them. **Refer to Figure 11.**

1. After installing the air proving device, test for continuity across the normally open contacts with the fan/blower off. You should read infinity (no continuity) when the fan/blower is off.
2. Turn on the fan/blower at the thermostat and test for continuity across the normally open contacts with the fan/blower running. You should now read continuity (a complete circuit) when the fan/blower is running.



**Ultra-Zone Steam Humidifiers  
Model S2000 & S2020  
Dimensional Data**

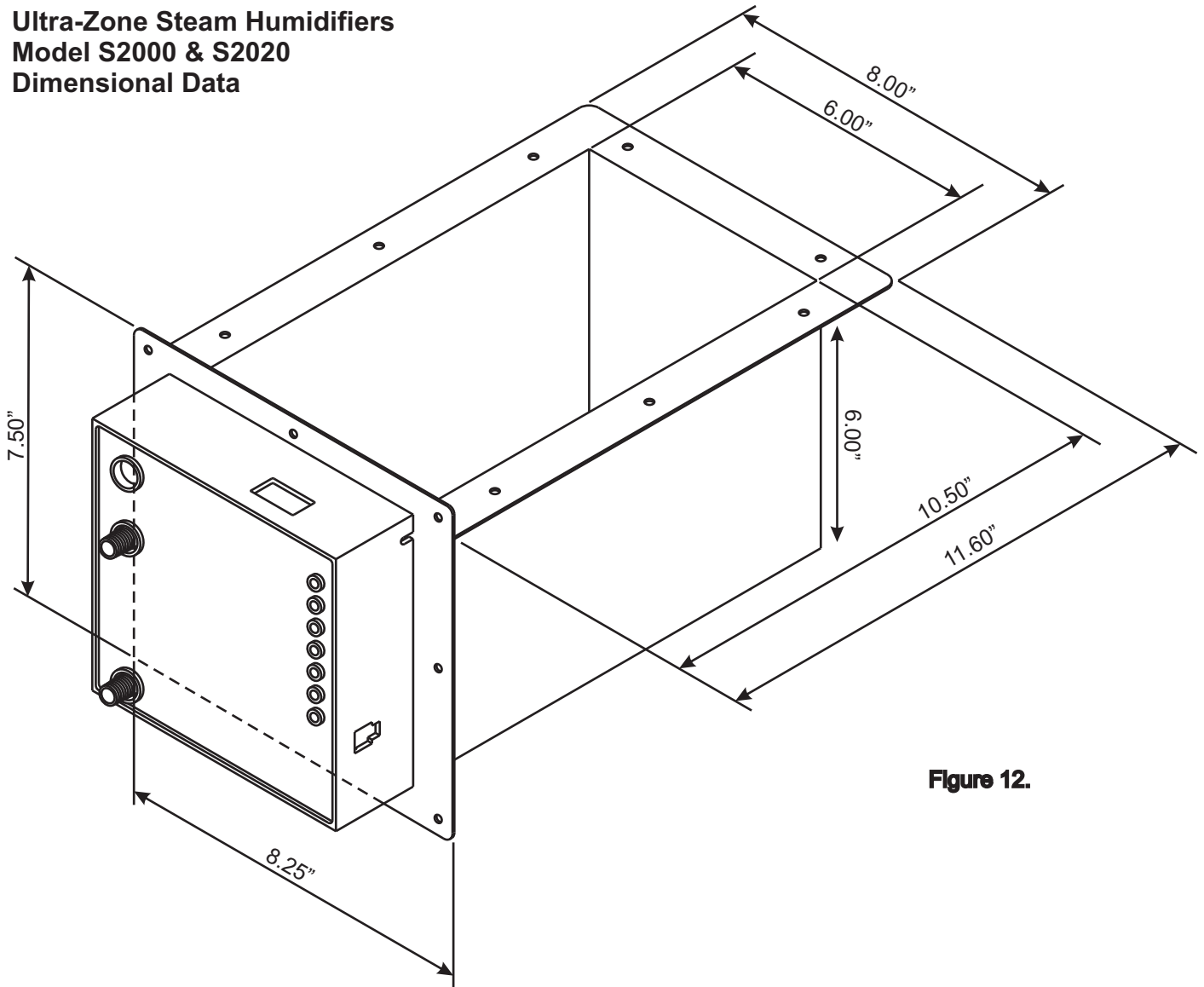

**Figure 12.**

Figure 12 reflects the basic dimensions of the Ultra-Zone S2000 or S2020 Steam Humidifier. This data is useful in determining the room needed to install the unit in a certain location. The data can also be used to determine the minimum duct size the Steam Humidifier can be inserted into. The Steam Humidifier should not obstruct more than 25% of the cross sectional area of the selected duct. For Example: The humidifier tank measures 8 inches wide (including the flange) times the length of 11.6 inches=92.8 square inches. We are only concerned with the obstruction on a flat plane. Which is why the flange is taken into account but not the depth of the tank. This assumes an up-flow configuration. If the configuration is horizontal, then the Steam Humidifier will obstruct approximately 70 square inches of duct area. The tank flange is no longer a factor.

At 92.8 square inches, the smallest duct plenum that can accommodate the Steam Humidifier mounted internally would be approximately 20" by 19". 20x19=380 square inches multiplied by .25 = 95 square inches.

Steam Humidifier square inches of obstruction= **92.8 square inches. Up-flow configuration.**  
25 percent of 20x19 duct= **95 square inches.**

Steam Humidifier square inches of obstruction= **69.6 square inches. Horizontal-flow configuration.**  
25 percent of 12x24 duct=**72 square inches.**

In either case, avoid installing the Steam Humidifier on any duct size where the unit will consume more than 25% of the cross sectional area of the duct at the point of insertion. Doing so may result in turbulent airflow, lower velocities and condensation inside the duct. Avoid all of these conditions by selecting an "under the duct" location and specify the SC100 decorative tank cover to give it a finished look.

**Suitable locations** to install your Ultra-Zone Steam Humidifier on an Up-flow or Horizontal HVAC System. Notice that some of the locations are X'd out. These are poor locations for the Steam Humidifier and may result in lower capacity output and/or excessive condensation. Try to avoid mounting the unit within 2 feet of any 90 degree turns. Allow at least 5 inches of clearance above the tank. The unit should not be installed within 5 feet of an Electronic Air Cleaner, 4-5 inch thick Media filters, or a UV Lamp. **Caution:** UV lamps may destroy certain plastics/rubber unless shielding is applied to those surfaces. **DO NOT install the Steam Humidifier on a Down-flow HVAC system.** **Avoid Fiberglass Duct-Board** as it cannot support the weight of the Steam unit when full of water. **DO NOT install the Steam Humidifier in an attic or crawl space exposed to freezing temperatures.**

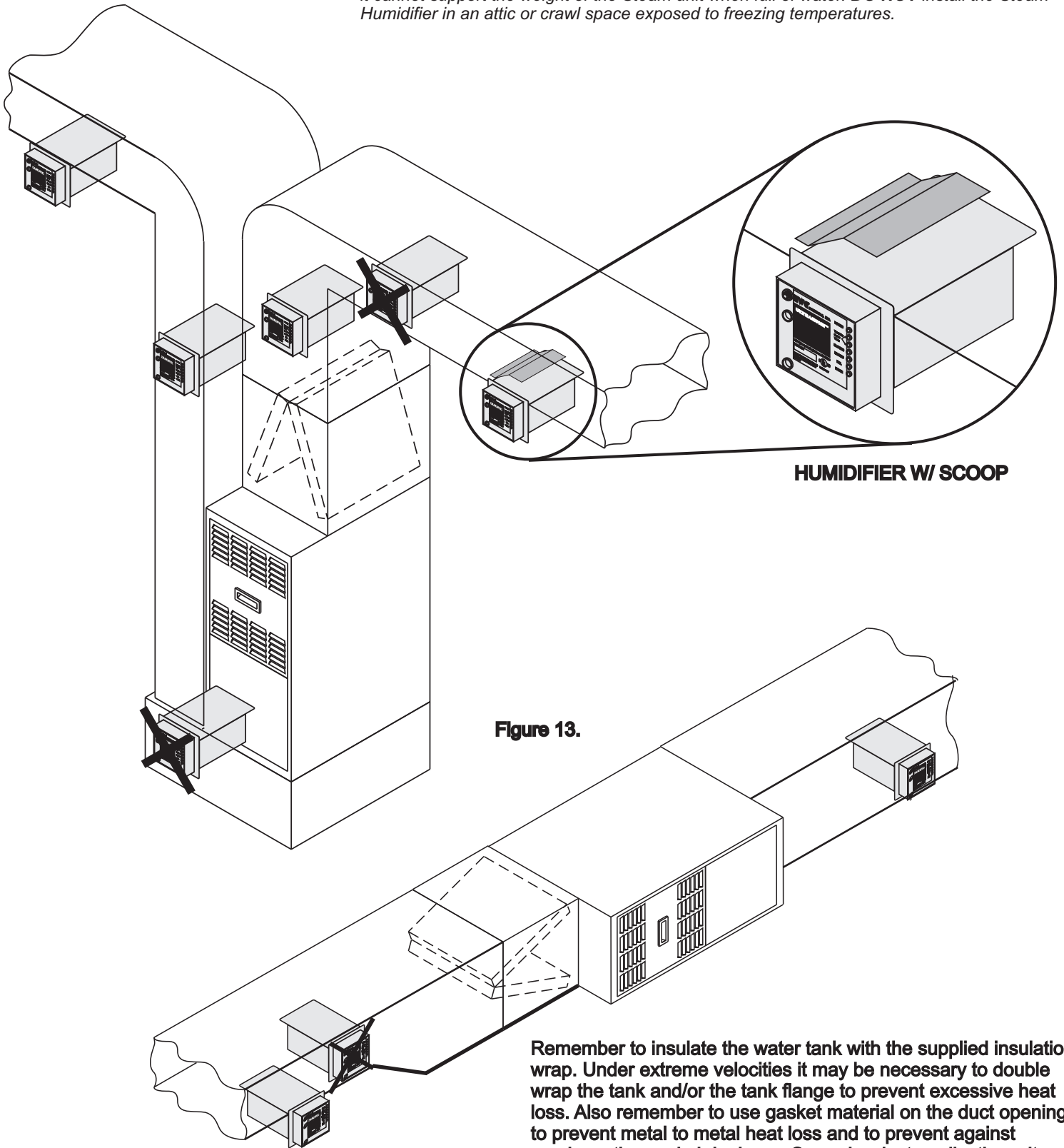

**Figure 13.**

**Remember to insulate the water tank with the supplied insulation wrap. Under extreme velocities it may be necessary to double wrap the tank and/or the tank flange to prevent excessive heat loss. Also remember to use gasket material on the duct opening to prevent metal to metal heat loss and to prevent against condensation and air leakage. On under-duct applications, it may be necessary to insert an Air-Ramp in the duct to induce the steam out of the tank. Contact Technical Support for assistance.**

## 10. SETTING THE HUMIDISTAT

It is recommended that humidistat settings of 30-45% not be exceeded. If condensation is noticed on windows during very cold outside temperatures, the humidistat setting should be lowered.

The maximum recommended relative humidity for your home depends upon many factors such as outdoor air temperature, type and placement of insulation, vapor barriers, effectiveness of weather stripping, type of windows and doors (including frames and jambs) and whether or not storm windows and doors are used. With all these variables it is nearly impossible to recommend a proper humidity setting. The best humidistat setting is one that you are most comfortable with. Also, as the outdoor temperature fluctuates, it may be necessary to adjust the humidity level of your system a few times during the heating season.

Refer to the "Relative Humidity Chart" as a starting point for your proper humidistat setting. Generally, in a tighter and better insulated house, the humidistat may be set higher than in a drafty, un-insulated house.

**IMPORTANT:** If the humidifier is installed in the return air plenum the humidistat must be located at least five (5) feet upstream from the humidifier. Fan should be operated in continuous mode when the humidistat is mounted in the return air plenum. Mounting the humidistat on an interior wall is always preferable to mounting on the return duct. But mounting the humidistat on an interior wall takes more time, material and labor than a return duct location. Sometimes it may be impossible to mount a humidistat on an interior wall and the return duct location is the only solution.

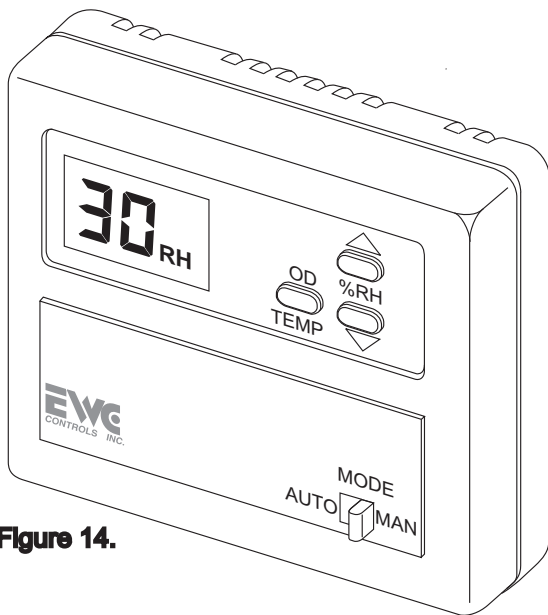

Figure 14.

Installation instructions for the 072000 model Humidistat are packaged with the 072000.

Your humidifier may include Model 062000 Humidistat. Installation instructions for the 062000 model are packaged with the 062000.

There are many ways to wire and control a humidifier. Refer to the wiring diagrams on pages 4 and 7.

### Variable Speed WIRING DIAGRAM

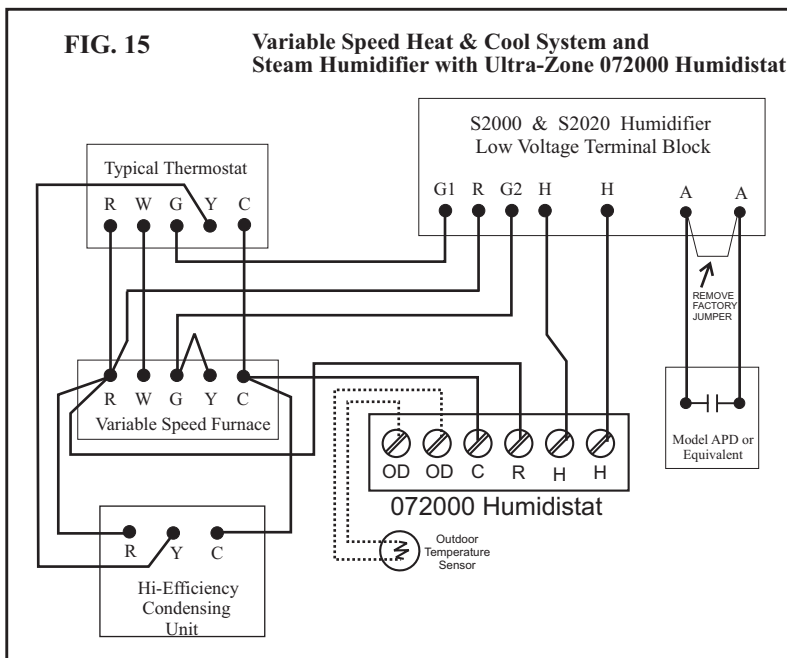

The diagram above should be followed if it is required to operate the fan system at high speed during the humidify operation. Such a requirement may be necessary if condensation occurs inside the duct-work due to the lower velocities of a variable speed system when only the fan is running. The "Y" circuit must be wired exactly as shown to achieve the correct operation. This wiring configuration may result in the loss of the "enhanced" latent effect operations of your variable speed HVAC system. If you do not want this to happen, you should consider installing a different type of whole house humidifier that does not require dominance over the HVAC fan and full CFM capacities while operating. Variations on this diagram are available. Contact EWC Controls Technical Support Hotline.

### RELATIVE HUMIDITY CHART

Outside Dry Bulb Temperature	Recommended Indoor Relative Humidity Setting
0 Deg. F	15%
10 Deg. F	20%
20 Deg. F	25%
30 Deg. F	35%
35 Deg. F and up	40-45%

# INITIAL START-UP \* SEQUENCE OF OPERATION \* SERVICE "LED" INDICATORS

## 11. START -UP & OPERATING SEQUENCE

Once the Steam Humidifier has been installed and the water, drain, humidistat and blower interlock connections completed, the humidifier may be started.

A. Disconnect the water line. Turn on the water supply and flush the line into a bucket. Reconnect the water line.

B. Set the humidistat to a setting higher than the room RH level.

C. Plug the S2000 Humidifier line cord into a 120 VAC, 20 amp source. (240VAC, 15amp for S2020).

D. The Green "POWER" LED should blink rapidly and the drain valve will open momentarily upon initial start up. The "FILL" LED will illuminate and water should begin to fill the Water Pan. The Power LED will now blink slowly.

E. When the water has reached the probe level the "FILL" lamp and fill valve will be turned off, and the "HEATER" LED and heater element will be turned on. The "POWER" LED will blink slow and steady.

F. Once the water reaches 170 deg. F. the "BLOWER" LED will illuminate and the system blower should start up.

G. If the above steps have been successfully completed, the humidifier is operating properly.

## 12. SERVICE "LED" INDICATORS

A. **POWER:** In normal standby mode, when the humidistat is not calling for humidity and the power cord is plugged in, the "POWER" LED should be blinking slowly. If the green "POWER" LED is not flashing when there is power to the unit, the CPU and/or circuit board may have failed.

B. **FILL:** When the humidistat closes, on a call for humidity, the "FILL" LED is illuminated, the Solenoid Valve is open and the water reservoir is filling.

C. **HEATER:** When the water reaches it's proper level the valve closes, the "FILL" LED goes out, the "HEATER" LED is illuminated, and the Heater begins to heat the water.

**NOTE:** *If the humidifier is unplugged while in steaming operation and then plugged back in, A rapid flashing of the "POWER" LED will occur and all other functions will stop! The unit wants to perform a water probe test, but cannot perform this test until the water cools down. Simply wait until the unit cools down and it will resume normal operations. To accelerate a cool down, simply turn the HVAC system fan on via the thermostat.*

D. **BLOWER:** When the water in the reservoir reaches approximately 170 deg. F. the "BLOWER" LED will be illuminated and the interlock wiring should turn the system blower on. Depending upon the water and ambient temperatures, it may take anywhere from four to twelve minutes for the water to heat to 170 deg. F. If the humidistat remains closed the "HEATER" and "BLOWER" LED's will both be illuminated at the same time and the "POWER" LED will be blinking slowly.

E. The "FILL" LED will illuminate and the water reservoir will refill at irregular intervals, depending on the boil off rate. The "HEATER" LED should remain illuminated unless the humidistat opens or the humidifier enters a drain cycle or failure mode.

F. **DRAIN:** This LED will be illuminated when the microprocessor cycles the humidifier into a Maintenance Mode. ***After a fan forced cool down period, the water is allowed to drain at 140 degrees F.*** The drain valve will then close and the fill valve will open to refill the reservoir and resume normal operation. This mode will last about one hour and the microprocessor will automatically restart the unit afterwards, if there is a call for humidity. This drain cycle will occur once every 8-12hours, to reduce the mineral concentration in the tank and let the heater cool-down. That will shed most deposits that have built up on the heater. **NOTE: The "POWER" LED will blink rapidly during Maintenance mode.**

**NOTE:** *A unique feature of the "S" series humidifiers is called "Fill on Request". The unit will not refill with water after a maintenance cycle, unless there is a demand for humidity from the humidistat. This ensures that the unit will not sit idle with standing water, which can stagnate over time.*

G. **FAILURE LED'S:** When service is required, these LED's will illuminate. If the humidifier enters a failure mode, it must be manually reset by disconnecting the power and then reconnecting it. **If the "Air" failure LED occurs, simply turn the Humidistat off or down then back up again to reset.**

**WATER:** This will occur when the reservoir is not filling up with water, not filling fast enough or the microprocessor cannot recognize that the water is touching the probe. Reverse Osmosis water or purified (distilled/deionized) water sources should be avoided, unless the final feed water measures at least 25 ppm conductivity.

**HEATER:** This will occur if the humidifier is not boiling off water during the "HEATER" cycle. Water in the reservoir is not reaching 170 deg. F. temperature, or the unit has not detected a request for water in a 50 minute steaming time period. Both red LED's will illuminate in this condition.

**AIR:** This will occur if the humidifier detects a loss of air flow for more than 4 minutes. A field supplied air proving device must be installed, wired and tested.

**THERMISTOR:** This will occur if a short or open is detected in the temperature probe.



### 13. MAINTENANCE/SPRING SHUTDOWN

Proper maintenance and removal of mineral deposits is still required on your steam humidifier in order to optimize performance. Annual cleaning is a must and more frequent cleaning may be necessary depending on the mineral content of the water in your area.

A post winter cleaning and shutdown, will prevent hard deposits from accumulating inside the bin, while the humidifier is idle over the summer. Do not allow the unit to sit idle for long periods without a proper cleaning and shutdown. Failure to do so will affect the performance of your steam humidifier.

**Maintenance and inspection of the unit requires removal of the humidifier from the duct. This can be done following these steps.**

- A. Unplug the power cord from the 120 volt source for S2000 (240 volt for S2020) and allow the water to cool for at least 30 minutes prior to removal.
- B. Turn off the water supply at the saddle tapping valve.
- C. Remove the cable assembly wire plug from the top of the plastic control housing.
- D. Drain the water with the manual drain valve. NOTE: The drain valve will be hot if the humidifier has not been allowed to cool.
- E. Disconnect the water and drain lines. NOTE: Some water may drain out of the water line. Have a small container ready to catch the water.

NOTE: Although the water has been drained, some water may still remain in the humidifier reservoir along with sediment. Be careful not to tip the unit over when removing it from the duct.

Remove the eight (8) screws from the front mounting plate.

- F. Slide the humidifier out of the duct.
- G. Remove the two (2) screws holding the tank baffle to the pan flange and remove the baffle from the unit. Scrape all mineral deposits from the baffle and wash baffle off as described in step J. Remove the Anode from the baffle plate and purchase a new one. Operating the unit without the Anode will degrade the performance and increase maintenance.
- H. Use a putty knife to scrape the minerals from the sides and bottom of the water reservoir. DO NOT scrape on the small temperature probe, or the heater element. Use a soft emory cloth or stiff nylon brush. *If necessary, fill the tank with vinegar and let it sit for several hours or even overnight allowing the scale to soften and making it easier to remove.*
- I. Carefully scrape the Water Level Probe to remove mineral deposits. Use soft emory cloth if necessary.

Clean the Water Probe Insulator, inside the pan, with a cloth and 50-50 mixture of water and vinegar, rinse with fresh water. Inspect for any mineral deposits on the plastic insulator. Repeat cleaning if necessary and thoroughly dry. Use a small nylon brush to clean deposits off the heater element and thermistor probe. **Be careful not to damage any of the components.**

- K. Rinse out the reservoir. Be careful to keep water off of the wiring compartment and the front cover of the humidifier. **Allow the unit to dry thoroughly before using!**
  - L. Reinstall the tank baffle and tighten the two (2) screws.
  - M. Re-install the unit in the duct and connect the water line and the drain lines. **Store the unit in this condition for the summer, or continue to the next step.**
- START -UP**
- N. Turn on the water supply. Inspect the water connections and drain fittings for leaks.
  - O. Plug-in the S2000 power cord to the 120 VAC (240 VAC for S2020) grounded outlet. DO NOT use an extension cord.

1. The green POWER light should blink rapidly until it detects a demand to humidify, then it will blink slowly.
2. If the humidistat is calling for humidity the water valve will energize and the water pan will fill with water.
3. The Heater element will energize to heat the water, and the Fan will start up to distribute the moisture

### 14. SERVICE INDICATORS

Seven LED lamps provided on the front panel indicate the functional status of the humidifier as shown in Figure 7 below.

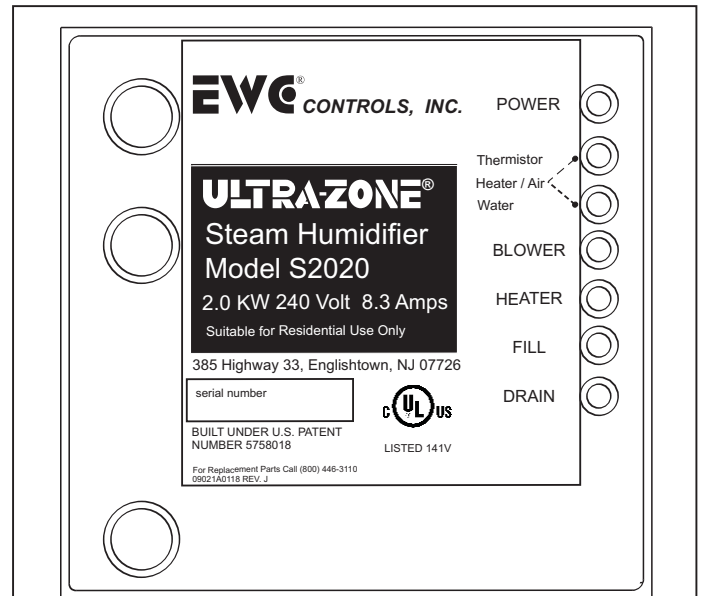

#### LED LIGHT EXPLANATION

POWER	- GREEN - BLINKING SLOWLY-IF POWER TO UNIT
THERMISTOR FAILURE	- RED - ON STEADY
HEATER FAILURE	- RED - BOTH LED'S ON STEADY
AIR FLOW FAILURE	- RED - BOTH LED'S ON FLASHING
WATER FAILURE	- RED - ON STEADY
BLOWER	- AMBER - ON STEADY WHILE PAN ABOVE 170 DEG F.
HEATER	- AMBER - ON STEADY WHILE HEATING (BOILING)
FILL	- AMBER - ON STEADY WHILE FILLING PAN
DRAIN	- AMBER - ON STEADY WHILE DRAINING PAN

#### IMPORTANT NOTE

ON THE INITIAL FILL AFTER INSTALLATION OR ANY TIME THE WATER PAN IS DRAINED THE PAN MUST FILL WITH ABOUT THREE (3) TIMES THE AMOUNT OF WATER AS REQUIRED IN THE NORMAL CYCLE OF FILLING. THE 'FILL TIMER' MAY TIME OUT BEFORE THE WATER LEVEL REACHES THE WATER LEVEL PROBE CAUSING THE 'SERVICE CYCLE' TO BE STARTED. **IF THE WATER FAILURE ILLUMINATES, UNPLUG THE UNIT FROM ITS POWER SOURCE, WAIT ABOUT 15 SECONDS AND RECONNECT THE POWER SOURCE. THE SERVICE LIGHT WILL GO OUT AND THE UNIT WILL CONTINUE FILLING TO THE CORRECT LEVEL.**

**FIG. 16**

## SERVICE INDICATORS

### A. The green "Power" light does not blink off and on.

1. The S2000 is not connected to an active 120 VAC 15 Amp power source. (S2020, 240 VAC, 10 AMP).
2. Call the Technical Support Hotline.

### B. The "HEATER" LED does not illuminate.

1. The humidistat is not closed, calling for humidity or the humidistat is wired incorrectly.
2. The unit is in the maintenance cycle.

### C. The HVAC Blower will not operate, but the "Blower" LED is on.

1. The blower "Field" wiring and/or interlock circuitry is incorrect.
2. The HVAC electric power is disconnected.
3. The humidifier internal "Blower" relay is defective. Call the Technical Support Hotline.
4. The HVAC Blower motor has failed.

### D. The HVAC Blower will not operate and the "Blower" LED is not on.

1. The water pan temperature has not reached a high enough temperature to activate the "Blower" relay, about 170 degrees Fahrenheit. This takes several minutes after the "HEATER" LED is illuminated. Depending on the water temperature and the surrounding condition, this may take up to 12 minutes. If the problem continues, the heater element may be defective or the thermistor temperature probe may be defective. Contact the Technical Support Hotline.

### E. Red Service Light (error #1) is on constantly.

THERMISTOR FAILURE ... This is an indication that the temperature probe is open or shorted to ground. May also indicate the probe has detected a pan temperature below 32 degrees F. Or in excess of 230 degrees F., resulting in a total shutdown. Try to reset the unit by unplugging the cord and reconnecting, or call Technical Support.

### F. Red Service Light (error #2) is on constantly.

WATER FAILURE ... This is an indication that the water fill time has been exceeded. The water level did not reach the probe tip in the given amount of time. It may also indicate an unsuccessful drain cycle.

1. The water line is shut off at the saddle valve.
2. The water line is crimped or pinched.
3. The water valve inlet screen is plugged. Remove the water line from the unit and check the screen found inside the inlet side of the valve.
4. Unit is connected to a water source which is distilled, over-filtered, de-mineralized, or from a reverse osmosis system. **Minimum 25 ppm water conductivity is required. \*The unit supply water must contain dissolved solids in the water, or the processor will not be able to detect the water level.**

5. The water valve may be defective and must be replaced See replacement parts.

6. The drain valve is unplugged or defective.

7. Debris is clogging the drain valve or drain line.

8. Reset the unit by unplugging the power cord and re-connecting.

### G. Both Red Service Lights (error #3) are on constantly. HEATER FAILURE... This is an indication that the water temperature is not increasing or reaching the boiling point.

1. Faulty heater element or faulty wire connection.

2. This can happen if the unit is operated without water in the pan as a result of a water level probe malfunction, due to lack of maintenance. The pan boils dry and overheats the water pan. If this condition occurs, call the Technical Support Hotline.

3. The unit has operated for 45-50 minutes without a request for water, due to a leaking water fill valve, which is filling the tank continuously.

### H. Both Red Service Lights (error #4) are flashing.

AIRFLOW FAILURE ... This is an indication that the system blower is not running or the blower/fan proving device has failed, is malfunctioning, or is not wired correctly. Check the blower motor and the interlock wiring. Refer to page 4, Figure 11.

### I. If the humidifier seems to operate in a random manner that doesn't seem to fit any of the pre-described conditions, check the following:

1. Check to make sure that the wires used to connect the humidifier to the humidistat are separate wires and not part of a multi-wire bundle used to hook up the furnace thermostat or any other device. The associated close wires may create an induced voltage in the humidistat wiring.

2. Make sure that the water level probe and plastic insulator are clean and free of mineral build-up. It may become electrically conductive to ground, sensing a false indication that the water level is correct.

3. If the electric solenoid valve makes a loud noise when it closes, install an optional water hammer arrester to absorb the spike. Frequent or erratic water fill cycles can be due to air turbulence, when mounted in the supply air plenum.

4. The water probe uses the natural conductivity of the water, to determine the proper water level in the reservoir. Water that has been de-mineralized or over filtered may not allow the unit to function properly. **Minimum 25 ppm of total dissolved solids must be present in the water. Add approximately 1 tablespoon of salt to the tank, to temporarily fix this problem.**

5. These steam humidifiers must be connected to dedicated outlets of the proper current and voltage ratings. The use of extension cords is not recommended.

**DO NOT cut off the grounded plug and/or hard wire this humidifier to line voltage.**

***This will void the warranty.***

ITEM	S2000 PART NO.	S2020 PART NO.	DESCRIPTION OF PART
1	2120	—	120 VOLT HEATER ASSEMBLY
1	—	2240	240 VOLT HEATER ASSEMBLY
2	2001	2001	24 VOLT SOLENOID VALVE ASSEMBLY
3	2002	2002	THERMISTOR PROBE ASSEMBLY
4	2003	2003	WATER LEVEL PROBE ASSEMBLY
5	2004	2005	CIRCUIT BOARD ASSEMBLY
6	2006	2006	DRAIN VALVE ASSEMBLY
7	2007	2007	TANK BAFFLE
8	2008	2008	INSULATION KIT (not shown)
9	WH 100	WH 100	WATER HAMMERARRESTER (not shown)
10	Z 100	Z 100	ANODE
11	2009	2009	UNDER DUCT STEAM COVER (not shown)
12	APD	APD	AIRFLOW PROVING DEVICE (not shown)

## SERVICE AND REPLACEMENT PARTS

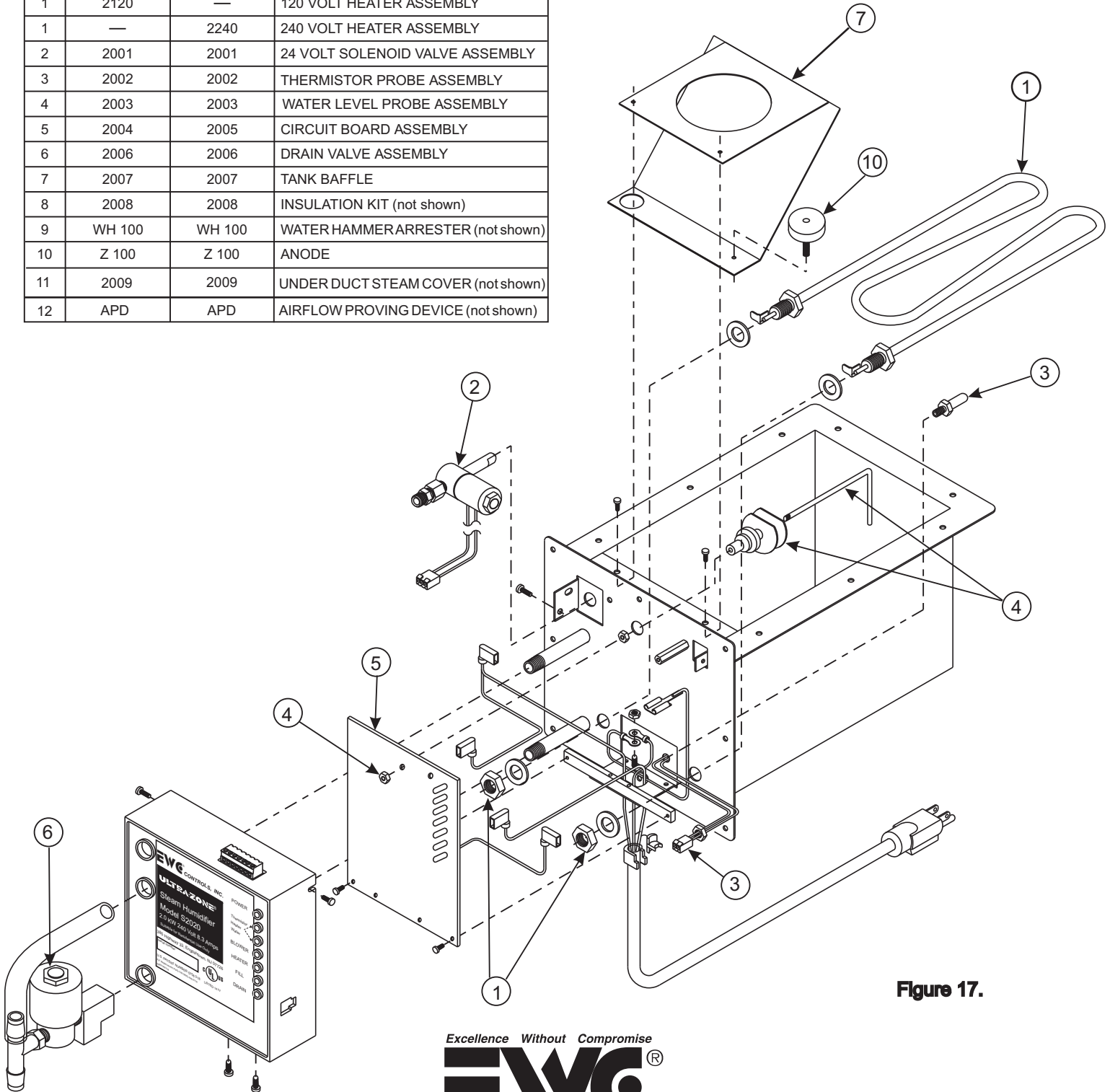

Figure 17.

Excellence Without Compromise

**EWC**<sup>®</sup>  
CONTROLS INC.

385 Highway 33 • Englishtown, NJ 07726

www.ewcccontrols.com

e-mail: Info@ewcccontrols.com

Tel. (800) 446-3110

Fax: (732) 446-5362

Figure 18

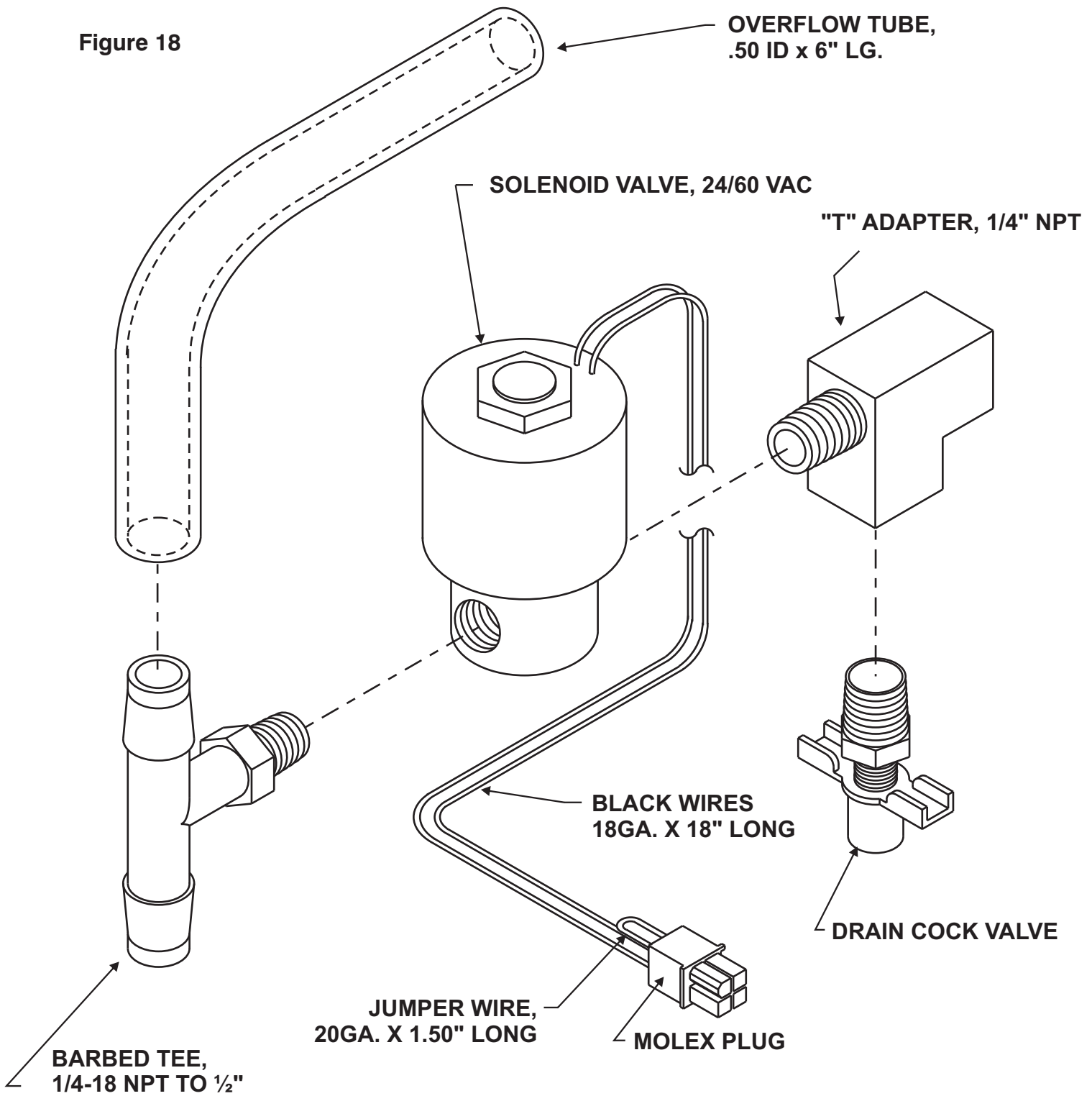

Excellence Without Compromise

**EWC**<sup>®</sup>  
CONTROLS INC.

385 Highway 33 • Englishtown, NJ 07726  
www.ewcccontrols.com e-mail: info@ewcccontrols.com  
Tel. (800) 446-3110 Fax: (732) 446-5362



**Your new  
Steam  
Humidifier may  
include this  
control. The  
instructions are  
included!  
Please refer to  
this Bulletin.**

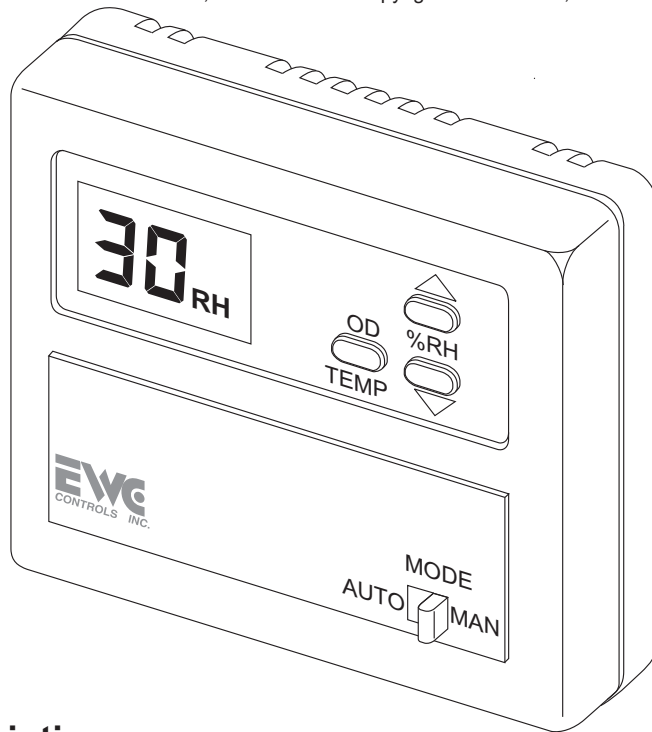

Package includes:  
1 #072000 Smart Humidistat  
1 Foam Gasket  
1 Mounting Template  
1 Technical Bulletin #TB213  
2 Mounting screws  
2 Wall anchors  
1 #OAS Outside Air Sensor

## General Description

The 072000 is a digital humidifier control that can automatically adjust the indoor humidity set point as the outside air temperature changes. This intelligent control will maintain accurate humidity levels and a more comfortable indoor environment.

The actual indoor relative humidity is always displayed on the LCD screen. When the **up** or **down** keys are pressed, the humidity set point is displayed and can be adjusted using the **up** and **down** arrow keys.

An outdoor temperature sensor is included, and must be connected in order to fully utilize the features of the 072000. The outdoor temperature sensor allows the humidistat to automatically adjust the humidity set point, to avoid condensation on windows. It is also a convenient way to read the outdoor air temperature at any time.

*The outdoor sensor is not required to use the Humidistat in the basic or manual mode.*

The 072000 operates on 24vac, and has a set of isolated dry contacts for activating the humidifier. Terminals are also provided for the Outdoor air Temperature Sensor. (Part# OAS)

The 072000 can be installed on the return air duct or, it can be installed on an interior wall within the conditioned space. EWC Controls recommends an interior wall installation. NOTE: If the return air duct is chosen as the location, the HVAC fan should be set to run continuously, in order to obtain an accurate sampling of the actual living space relative humidity condition.

## **Ultra-Zone HUMIDIFIER**

### Z100 ASSEMBLY

# APPLICATION NOTE **AN 131**

INSTALLATION INSTRUCTIONS & OWNER'S MANUAL  
Z100 REPLACEMENT INSTRUCTIONS  
SUPPLEMENT TO THE Ultra-Zone  
ELECTRONIC STEAM POWER HUMIDIFIERS  
MODEL # S2000 AND S2020

The Ultra-Zone steam humidifier now comes equipped with a factory installed Z100, which acts as a sacrificial metal. Put simply, minerals in the water will attack and cling to the Z100. The minerals will not attack the other components inside the humidifier as long as the Z100 is present and active.

This results in a dramatic decrease in mineral and scale build up on the critical components inside the tank. In particular, it means less scale build up on the heating element which is subject to damage from excessive scaling and over heating. This also means that efficiency stays high and preventive maintenance is faster and easier.

The Z100 is positioned on the baffle plate inside the tank and is easily removed and replaced. Remember that the Z100's job is to become the target of mineral attack, so it will be heavily covered with scale and *should be replaced annually for best results.*

To remove the Z100 you must have already unplugged and shutdown your steam humidifier and allowed it to cool. The water tank has been drained, the water supply, drain lines and electrical wiring have been disconnected and the unit has been removed from the duct.

Refer to the blow up view on Page 11. Using a phillips screwdriver, remove the two screws that hold the baffle plate to the tank. Lift the baffle slightly back to clear the water probe and then straight up and out of the tank. You can then see the round Z100, or rather what is left of it after a single season. Notice the heavy scale build up on the Z100 that would have been on your element, if the Z100 was not there. Use a rag or pliers to grasp the edges of the Z100 and simply unscrew it from the baffle plate. Rinse off or wipe away any residual scale from the baffle plate and install a new Z100. Leave a slight gap between the bottom of the Z100 and the baffle plate. Now re-insert the baffle plate into the tank and secure with the two screws that were removed previously. It's that simple.

The Z100 can also benefit the older model steam humidifiers. Simply lay the Z100 down into the baffle plate in the same location as the factory installed model. *DO NOT lay the Z100 down into the main tank. It may come in contact with the heating element and damage it.* The dimensions of the baffle plate prevent the Z100 from falling down into the tank.

The Z100 is just the latest innovation in the Ultra-Zone Steam Humidifier line as we continue in our pursuit of Excellence Without Compromise.

## **SC100** PART # 2009 Installation Instructions

SUPPLEMENT TO THE Ultra-Zone ELECTRONIC STEAM  
POWER HUMIDIFIERS  
MODEL # S2000 AND S2020

The Ultra-Zone steam humidifier can be equipped with a field installed Decorative and Protective Cover for Under the Duct Installations only. The SC100 provides a protective shell around the exposed insulated tank and provides a visually pleasing finish to the installation.

The SC100 is just the latest innovation in the Ultra-Zone Steam Humidifier line as we continue in our pursuit of Excellence Without Compromise.

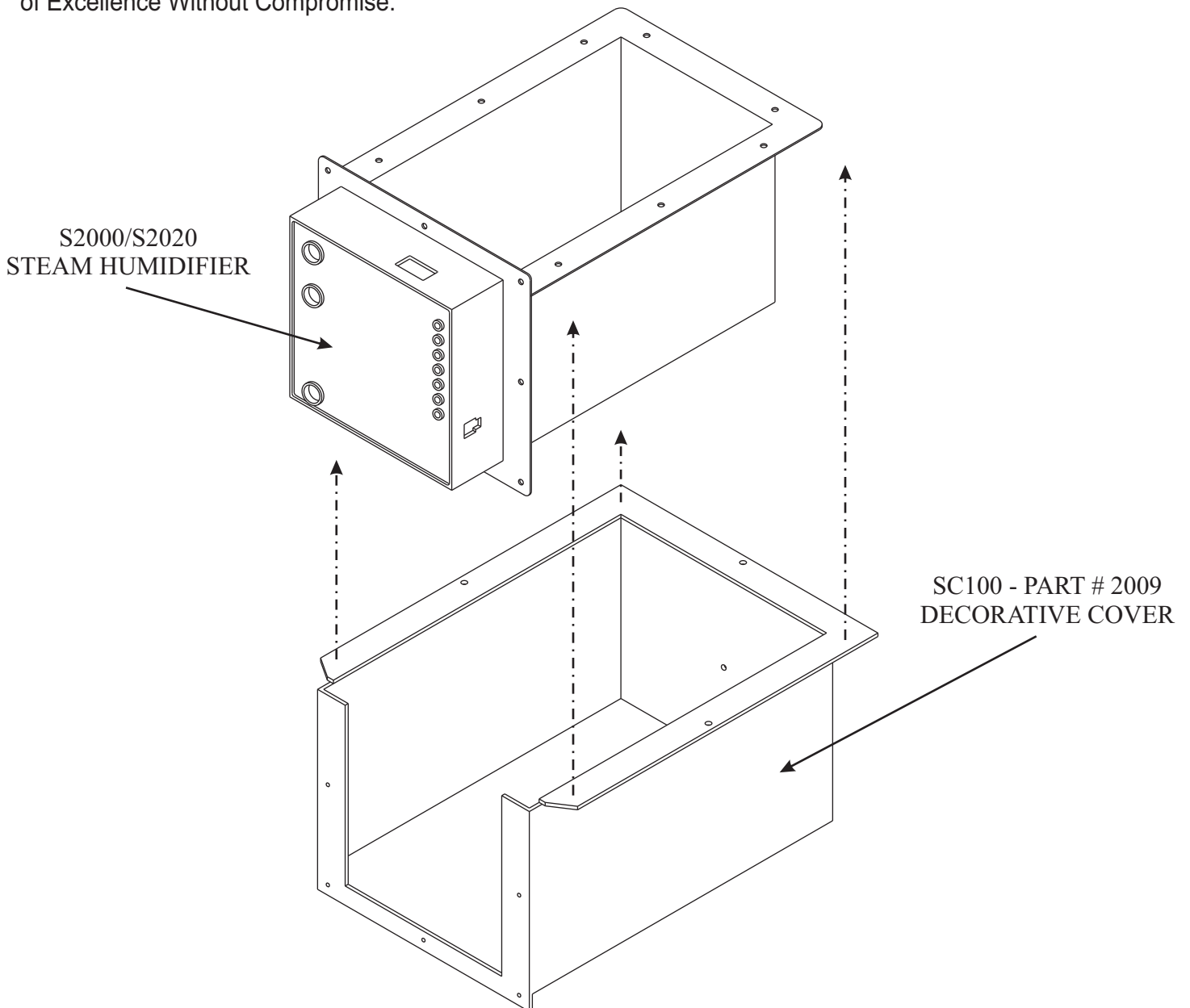

**DOCUMENT YOUR PRODUCT, INSTALLATION & MAINTENANCE DATA HERE FOR FUTURE REFERENCE!**

Model Number: \_\_\_\_\_ Serial Number: \_\_\_\_\_ Date Code: \_\_\_\_\_

Date Purchased: \_\_\_\_\_

Date Installed: \_\_\_\_\_

Date Inspected: \_\_\_\_\_

**Maintenance Schedule:**

Annually      Bi-Annually      Quarterly      Monthly

Date of Service: \_\_\_\_\_ Service Performed: \_\_\_\_\_

Date of Service: \_\_\_\_\_ Service Performed: \_\_\_\_\_

Date of Service: \_\_\_\_\_ Service Performed: \_\_\_\_\_

Date of Service: \_\_\_\_\_ Service Performed: \_\_\_\_\_

Date of Service: \_\_\_\_\_ Service Performed: \_\_\_\_\_

Date of Service: \_\_\_\_\_ Service Performed: \_\_\_\_\_

Date of Service: \_\_\_\_\_ Service Performed: \_\_\_\_\_

Date of Service: \_\_\_\_\_ Service Performed: \_\_\_\_\_

Date of Service: \_\_\_\_\_ Service Performed: \_\_\_\_\_

Date of Service: \_\_\_\_\_ Service Performed: \_\_\_\_\_

Date of Service: \_\_\_\_\_ Service Performed: \_\_\_\_\_

Date of Service: \_\_\_\_\_ Service Performed: \_\_\_\_\_

Date of Service: \_\_\_\_\_ Service Performed: \_\_\_\_\_

Date of Service: \_\_\_\_\_ Service Performed: \_\_\_\_\_

Date of Service: \_\_\_\_\_ Service Performed: \_\_\_\_\_

Date of Service: \_\_\_\_\_ Service Performed: \_\_\_\_\_

**COMMENTS:** \_\_\_\_\_

\_\_\_\_\_  
\_\_\_\_\_  
\_\_\_\_\_  
\_\_\_\_\_  
\_\_\_\_\_  
\_\_\_\_\_  
\_\_\_\_\_