

D U C T M A T E

# SpiralMate®

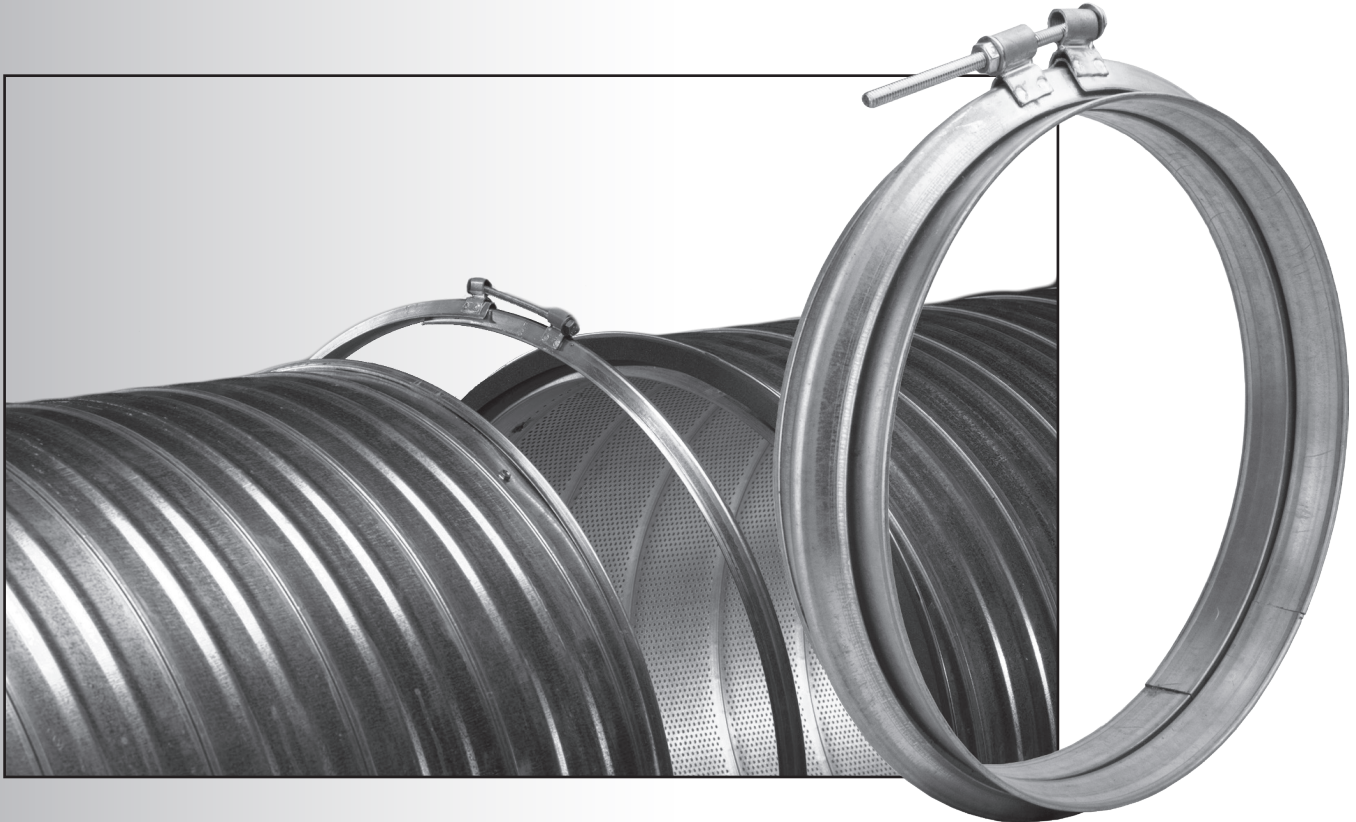

## Round Duct Connection System

**Superior Installation Speed, Versatility, Airtight Integrity and Aesthetics**

- Considerably less overall cost than light gauge angle rings
- Eliminates sealant costs and the associated labor
- One piece seamless connector clamp eliminates unsightly screws between connections, is used as an architectural feature, plus it is safer and easier to install
- Strong, split ring design “adjusts” to fit duct and fitting diameter variations
- Available in two profile sizes and virtually any alloy to fit duct ranging from 8” to over 100” diameters
- Replaces welding on gored fittings and allows elbows to be fully adjustable
- New Press-on Inner ring makes double wall duct systems a snap



**DUCTMATE®**  
**Industries, Inc.**

### DESCRIPTION

A 3 piece round connector system consisting of 2 precision roll-formed mating flanged rings injected with specially formulated 5511M integral mastic designed to seal on contact with the duct-wall. A specialized high density neoprene gasket is used to seal the mating flanges and the connection is completed with a one piece precision roll formed connector clamp with a specially designed adjustable single point fastener that fits effortlessly around the two mating flanged rings. For mining or unique application an alternative "Ventmate" connector clamp with the same high quality neoprene gasket embedded into it can be used. Consult factory for Ventmate applications.

### BASIC USE

The Spiralmate Round Duct Connector was developed to provide a strong and leak free connection without the use of duct sealants.

### SPECIAL CHARACTERISTICS

The Spiramate System is a self-contained connector system that was specially developed to simplify and lower the installed cost of round duct systems compared to light gauge angle rings and traditional couplers. By eliminating the need for external sealant, fasteners at the joint along with the additional manpower associated with other connections, the Spiralmate can be installed and connected by one person in a fraction of the time it takes for two or more workers to complete other round connections.

Spiralmate has been tested to 18" w.g. positive pressure and 10" w.g. negative pressure (complete test data available upon request)

Flange/Closure Ring Steel: Hot dipped galvanized steel  
 Mastic: DM5511M  
 Gasket: Ductmate Neoprene and Ductmate 440

### LIMITATIONS

The Spiralmate Small Profile (8" - 38" Duct Diameters) Round Duct Connector is not recommended for applications with spiral duct gauges heavier than 20 GA or lighter than 28 GA.

The Spiralmate Large Profile (30" - 72" Duct Diameters)\* Round Duct Connector is not recommended for applications with spiral duct gauges heavier than 16 GA or lighter than 28 GA.

Both Spiralmate Profiles will accept 12 GA longitudinal duct seam.

Some duct manufacturers may weld on the seams to keep them from falling apart once the duct is manufactured. These welds may need to be ground down so they can fit the pocket, this will not compromise the duct seam as long as the spiral flanges are attached just after grinding.

*\* For Large Profile sizes 30" - 38", consult factory for availability*

### PACKAGING INFORMATION

The Spiralmate Round Duct Connector system consists of the following components:

- Two mating Round Duct Connector Flanges with an integral mastic in the duct receiving pocket.
- A Closure Ring roll-formed from hot dipped galvanized steel.

#### Quick Ship Program

- 50 pieces or less ships in 24 hrs, if entered before Noon
- If after Noon; ships in 48 hrs
- Sizes 8" - 44" **Galvanized Only**

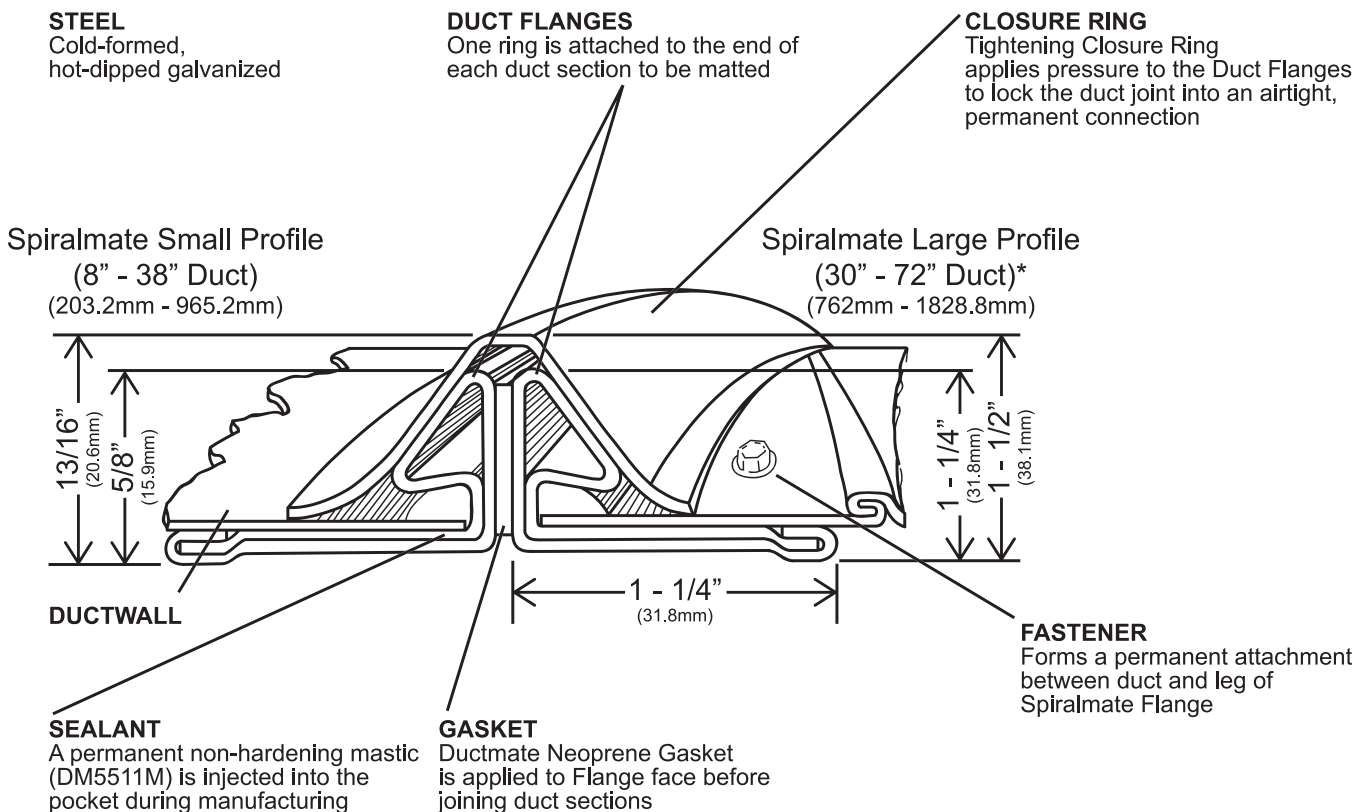

\* For Large Profile sizes 30" - 38", consult factory for availability

## INSTALLATION INSTRUCTIONS

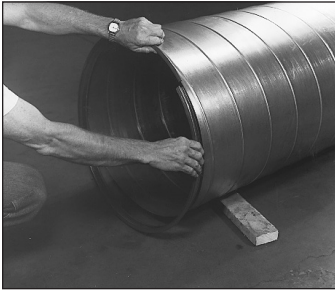

1. Start duct flange by inserting duct end into flange pocket at the break in the ring.



5. The break in the flange will allow a portion of the leading edge of the duct to be visible. Apply a short piece of Ductmate 440 gasket to the flange face over this visible leading edge on **both** mating flanges.\*

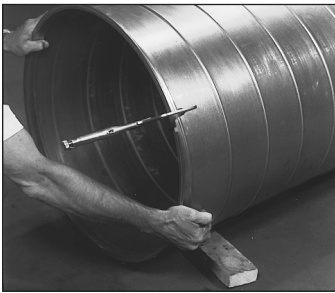

2. Seat flange permanently by pressing it so the leading edge of the duct is seated in the pocket of the flange and penetrates the sealant.

Hold flange in position with vise-grip a few inches from the break.

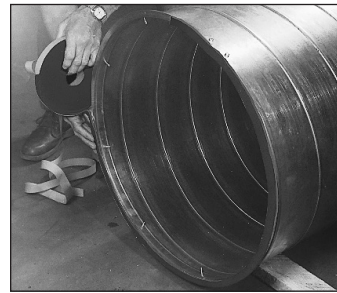

6. Complete the gasket application by installing Ductmate Neoprene gasket on the face of the flange around the entire circumference of **one** of the mating flanges.

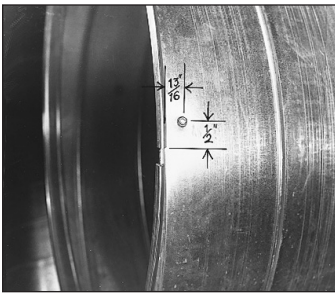

3. Begin securing the leg of the flange to the duct section by placing a pop rivet, screw, or spot weld within 1/2" of the end of the flange break. The fastener should be placed no closer than 3/4" or further than 1" from the face of the flange.

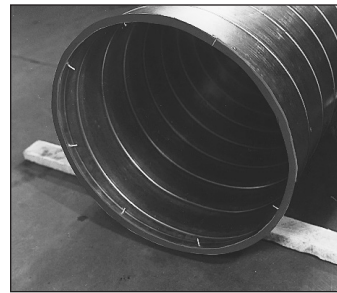

7. The end of the gasket should butt up to the beginning.

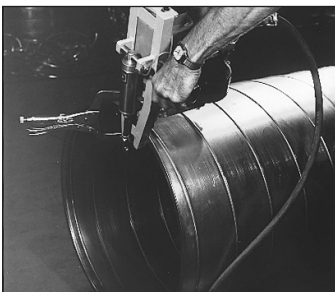

4. Continue in the same direction around the duct at evenly spaced intervals, as noted below left. Place the last fastener within 1/2" of the end of the duct flange.

*Using the Ductmater or Repeater Pro is optional but can save time and increase product consistency.*



8. Slip outer closure ring over end of duct. Align flanges using Spiralmate alignment grips.

8" - 18" duct - 8" on center  
 20" - 28" duct - 12" on center  
 30" and larger duct - 18" on center

\* Because most spiral duct is not true to size it may be necessary to cut a larger gap in the flange at the break. There **must be** a gap at the break.

## INSTALLATION INSTRUCTIONS



9. Slide closure ring over mating flanges and insert bolt.

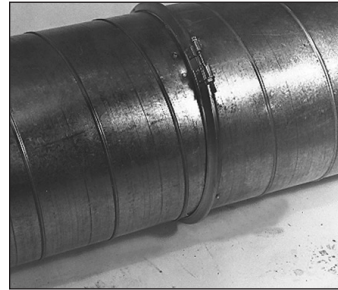

11. A completed, air-tight, round transverse duct joint. Fast, neat and clean.



10. Tighten the bolt on the closure ring until it makes even contact around the circumference of the duct sections. Tap around joint with hammer if necessary to seat flange while tightening.

### IMPORTANT:

On duct sizes 72" and larger consult factory for additional assembly and installation information.

## SPECIAL TOOLS



### Spiralmate Alignment Grips

These modified Alignment Grips help you quickly align your Spiralmate flanges, further reducing your labor time and costs.

**Part Number:**  
AG2001



### Spiralmate Nut Runners

Custom deep dish sockets designed to open and close the Spiralmate Closure Band. Available in two sizes 7/16" small and 9/16" large.

**Part Numbers:**  
NUTRUNS/NUTRUNL

Frequently a contractor installing a high velocity duct system will employ a duct joint with which either he or his work force have no experience. In such a case, it is strongly recommended that the contractor promptly test the initial 100 to 300 feet of duct before installing any more duct. This test will quickly reveal whether or not the workmen can make this joint air-tight in an economical manner.

*Reprinted from SMACNA High Pressure Manual.*

# Press-On Inner Rings

## Revolutionary Design For Quick, Hassle-Free Installation

### DESCRIPTION

The Press-On Inner Ring was specifically designed to significantly reduce installation time and labor cost. This system uses a double-sided pressure sensitive adhesive to bond the outer flange and inner ring without the need for costly welding. There are also no issues with aligning the rings to fit around the insulation and inner diameter of the duct because the outer flange and Press-On Inner Ring are installed on the ductwork separately.

### BASIC USE

Designed to protect insulation installed inside spiral duct from damage and prevent fibers from breaking away into the airstream. Installs with an easy to use peel and stick press-on gasket that quickly secures the cut edges of insulation to the duct wall.

### SPECIAL CHARACTERISTICS

- Double Sided high strength PSA tape to adhere
- Simplifies installation of double wall duct
- Available in 1" and 2" rings
- Inner-ring adjusts to fit the variations in pipe diameter
- Tested to 10" W.G. positive pressure
- Eliminates welding or fasteners
- Can be installed on-site

### INSTALLATION INSTRUCTIONS

1. Remove backing from adhesive gasket and starting with the split in the Inner Ring apply on the opposite side of the Spiralmate flange split.
2. Working in one direction around the Inner Ring, apply pressure to the areas where the adhesive gasket makes contact with the flange face to attach.

### PACKAGING

The Press-On Inner Rings are sold as single rings.

### ORDERING INFORMATION

Part Number Example:  
IIR\*30GAPSA

Insulation Thickness	Product Type	Size of Inner Diameter		Alloy	Adhesive
1 = 1" 2 = 2"	IR = Inner Ring	†8 = 8"	40 = 40"	GA = Galvanized GN = Galvannealed AL = Aluminum AZ = Aluminized S4 = 304 Stainless Steel S6 = 316 Stainless Steel  <b>1" Only</b> PVC = PVC Coated	PSA = Pressure Sensitive Adhesive
		†10 = 10"	42 = 42"		
		12 = 12"	50 = 50"		
		14 = 14"	52 = 52"		
		16 = 16"	54 = 54"		
		18 = 18"	56 = 56"		
		20 = 20"	58 = 58"		
		22 = 22"	60 = 60"		
		24 = 24"	62 = 62"		
		26 = 26"	64 = 64"		
		28 = 28"	66 = 66"		
		30 = 30"	68 = 68"		
		32 = 32"	70 = 70"		
		34 = 34"	72 = 72"		
		36 = 36"			
		38 = 38"			

† Only available for 1" insulation

\*Insert W for a welded split

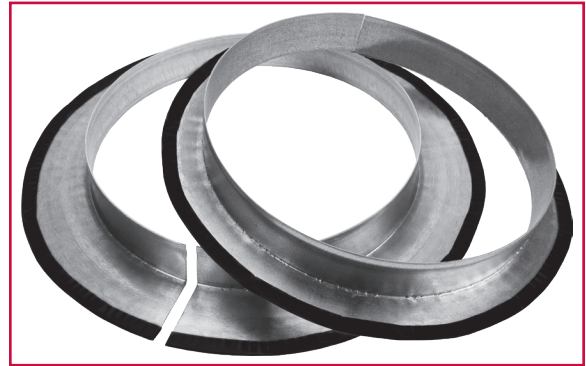

Small Profile Dimensions

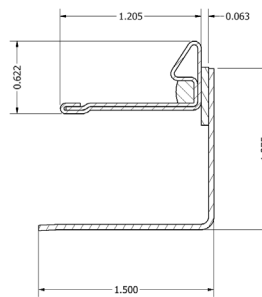

Large Profile Dimensions

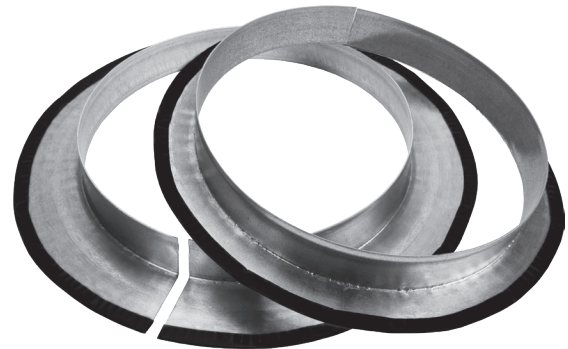
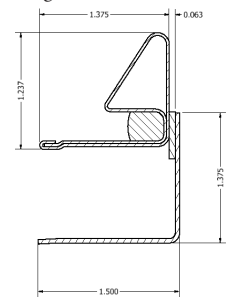

# LIMITED PRODUCT WARRANTY

Ductmate warrants that Spiralmate® and Press-On Inner Rings when properly installed and maintained, will be free from defects in material and workmanship, and will comply with all written specifications made by Ductmate at the time of sale. Ductmate's warranty shall run for a period of one year from the date of manufacture.

**Warranty Product Limitation:**

The warranty stated above is in lieu of all other warranties, express or implied, including but not limited to the implied warranties of MERCHANTABILITY AND FITNESS FOR A PARTICULAR PURPOSE. Although Ductmate may have suggested the product, or provided written or oral advice to the Purchaser, it is the Purchaser's responsibility to test and determine the suitability of Spiralmate® and Press-On Inner Rings for the intended use and purpose, and Purchaser and/or its customer assumes all risk and liability whatsoever regarding such suitability.

**Limitation of Liability:**

In the event of a breach of the above warranty, Ductmate's sole obligation, and Purchaser's sole and exclusive remedy, shall be, at Ductmate's option, repair or replacement of any defective products, or refund of an applicable portion of the purchase price. Ductmate shall have no liability for costs of removal or reinstallation of the product. The Purchaser agrees that no other remedy, including but not limited to loss of profits, loss sales, injury to person or property, or any other special, incidental or consequential damages, shall be available to the Purchaser for any claim arising out of this Agreement, regardless of whether such claim is made in contract or in tort, including strict liability in tort. In no event will Ductmate be obligated to pay damages to the Purchaser in any amount exceeding the purchase price that the Purchaser paid to Ductmate for the allegedly defective product. This product must be used in conjunction with the correct duct diameter.



**Charleroi, PA**  
210 Fifth Street  
Charleroi, PA 15022  
724-258-0500

**Lodi, CA**  
810 S. Cluff Avenue  
Lodi, CA 95240-9141  
209-333-4680

*Additional Manufacturing and Warehousing in  
Monongahela, PA and Wagoner, OK*

1-800-245-3188 • [www.ductmate.com](http://www.ductmate.com)

© Copyright Ductmate Industries, Inc. All rights reserved.



Ductmate Is A Proud Member Of The Following Organizations:



Distributed By: