

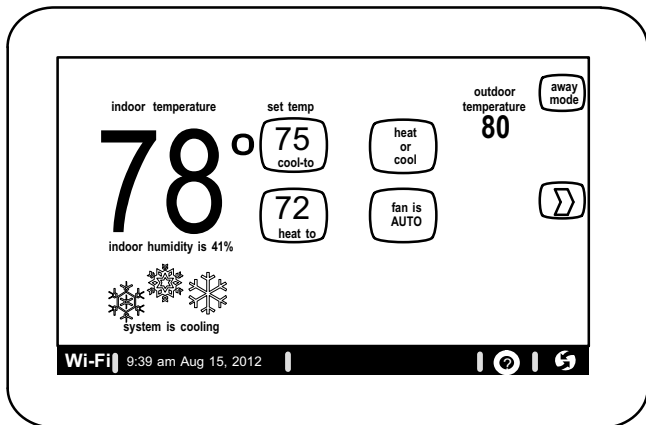

© 2012
ALLIED AIR ENTERPRISES
215 METROPOLITAN DR.
WEST COLUMBIA, SC 29170



**THIS MANUAL MUST BE LEFT WITH THE HOMEOWNER
FOR FUTURE REFERENCE**

NOTICE

**Read this manual before programming this thermostat.
Use this thermostat only as described in this manual.**

INSTALLER'S SYSTEM SETUP GUIDE

Comfort Sync™ Thermostat

Touch Screen Programmable Communicating Thermostat

CONTROLS

507064-01
11/12
Supersedes 09/12

TP Technical
Publications

Comfort Sync-Enabled Units

A97USMV	A97DSMV	A80US2V	A80DS2V
4SCU18LS	4SHP18LS	4SCU16LS	4SHP16LS
BCS2M_S			

Shipping and Packing List

- 1 - Comfort Sync™ thermostat
- 4 - Mounting Screws
- 4 - Wall Anchors
- 1 - Installation Quick-Start Guide
- 1 - Installer's System Setup Guide
- 1 - Homeowner's Manual
- 1 - Warranty card



Table of Contents Page

Technical Description/Features	3
Installation and Setup	4
System Settings screen	4
Change settings (dealer info, daylight savings, fan circulate)	5
Table 1. System settings defaults and ranges	6
Set Time and Date	7
Add or Remove Non-communicating equipment	9
Maintenance Timers	9
Outdoor Unit	10
Humidifier	11
Dehumidifier	12
Adjust a setting screen	13
Configure Humidifier	15
Configure Dehumidifier (Aux. Dehum. installed)	16
Configure Dehumidification (no dehumidifier installed)	17
Humidification and Dehumidification Modes—how they work	18
Use the Test Features	19
Set up Equipment Parameters	20
Use the Diagnostic Features	21
View and Clear Alerts	22
Enable Wi-Fi from User Home Screen	24
Register the Comfort Sync™ thermostat	25
Personal Computer account registration to Comfort Sync™ server	26
Access Installer Program from User Home Screen	28
Reconfigure a System	29
Stage Delay Timers & Differentials	30
Smooth Setback Recovery (SSR)	31
Heat Pump, Dual Fuel and Balance Points	32
Gas Heat Control Mode	34
Table 2. Variable Capacity Furnace Operation	35
Table 3. Adjustable Parameters (Installer)	37
Table 4. Adjustable Parameters (User)	43
Table 5. Alert Codes and Troubleshooting	45
Table 6. Troubleshooting Tips	55
Wiring Diagrams	59
Thermostat wire termination in communicating system	63

Setting up typical Comfort Sync systems

Indoor Unit	Outdoor Unit	page
Comfort Sync-enabled furnace	Comfort Sync-enabled AC	65
	non-communicating AC	66
Comfort Sync-enabled furnace (dual fuel)	Comfort Sync-enabled HP	67
	non-communicating HP	not supported
Comfort Sync-enabled air handler	Comfort Sync-enabled AC	68
	non-communicating AC	69
Comfort Sync-enabled air handler	Comfort Sync-enabled HP	70
	non-communicating HP	71



CAUTION

This is a 24VAC Class 2 thermostat. Do not install on voltages higher than 30VAC.

Do not switch system to cool if the outdoor temperature is below 45°F (7°C). This can damage the cooling system.



WARNING

Electric shock hazard.

Always turn off power at the main power source by switching the circuit breaker to the OFF position before installing or removing this thermostat.

All wiring must conform to local and national building and electrical codes and ordinances.

Revision History

07-2012	Preliminary release (draft)
09-2012	3rd draft

Comfort Sync™ Thermostat - Technical Description and Features

The 24VAC Comfort Sync™ thermostat (figure 1) is an electronic communicating, color display touchscreen, 7-day programmable thermostat. It stores system parameters and settings in nonvolatile memory (i.e., it retains data when electrical power fails or is turned off). It is designed for 4-wire connection to other communication devices as listed in figure 1.

The Comfort Sync thermostat can connect to online services via the internet through the homeowner's Wi-Fi access point. After online registration is completed, the system may then be accessed by the homeowner from anywhere using a remote internet connection via computer or personal communicating device.

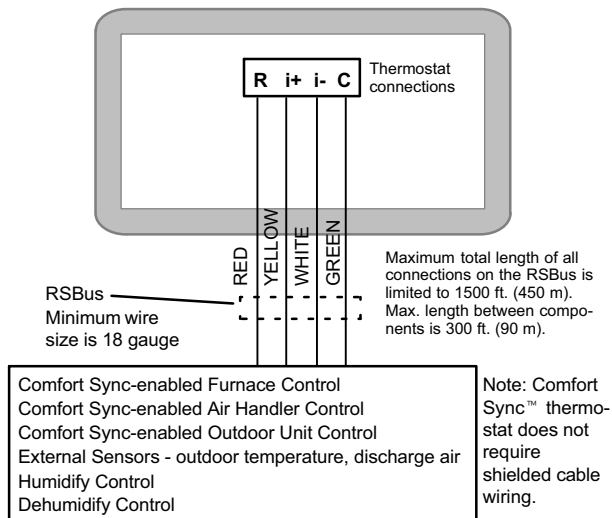

Figure 1. Comfort Sync system

BEST PRACTICES! Keep all communication wiring as far away from house electrical wiring and large electrical appliances as possible (15' [5m] recommended).

The thermostat also:

- supports three languages (English, French, Spanish),
- supports air conditioning units or heat pump units with up to four stages of heat / two stages of compressor operation (2 stages of heat pump heating, 2 stages of auxiliary back-up heating, 2 stages of emergency heating),
- supports Indoor Air Quality with time-based notification of consumables including media filters, UVC bulbs, and humidifier pads service / replacement,
- supports variable-capacity / multi-stage heat/cool, universal compatibility (gas/electric/heat pump/ac), and is dual fuel capable (Comfort Sync-enabled HP only) with two balance points.

Important

Connections to non-communicating outdoor units and accessories are described in the Quick-Start Installation guide. (Wiring diagrams are also shown beginning on Page 59 of this manual.)

Supports

- Humidification Measurement and Control,
- Dew Point Adjustment Control
- Dehumidification Measurement and Control
- Auxiliary Dehumidifier
- Multi-Stage HVAC Systems
- Equipment Maintenance Reminders
- Autochangeover Mode -- Permits control of heating, cooling, humidification, and dehumidification without user involvement.

Outdoor Temperature Sensor (option)

Communicating outdoor units contain a built-in outdoor temperature sensor.

Installation and Setup

IMPORTANT! When determining the location for the W-Fi thermostat, be sure it is in an area near enough to the homeowner's Wi-Fi router to ensure good communications signal between the thermostat and the router. (**Hint:** use a smart phone with Wi-Fi to find and determine signal strength.)

Refer to the *Quick Start Guide* for information about installing the thermostat on a wall and for wiring diagrams for field wiring the thermostat to the system using one of a number of possible configurations. (Wiring diagrams are also shown beginning on Page 59 of this manual.)

NOTE - If electric heat strips are used with an Comfort Sync-enabled air handler, the strips **MUST** be configured on the air handler control (AHC) board before beginning the "discovery" sequence below.

After all wiring connections are made, apply power to the system. 24VAC will power up the thermostat.

After power is applied to the thermostat for the first time, the processor checks the system for installed communicating devices, the screen display changes then is followed by "Use this thermostat?" screen.

Touch **press here** to continue. During the setup process, alerts may pop open to provide the installer with information that affects the setup. **Correct the cause of any such alerts prior to continuing setup.**



"System settings" (figure 2) appear first. As you use the up/down arrows to scroll through the settings, the right hand side will show the current value. For example, **current value:** 9:39 am Aug 15, 2012 shows the current date for Time and Date.

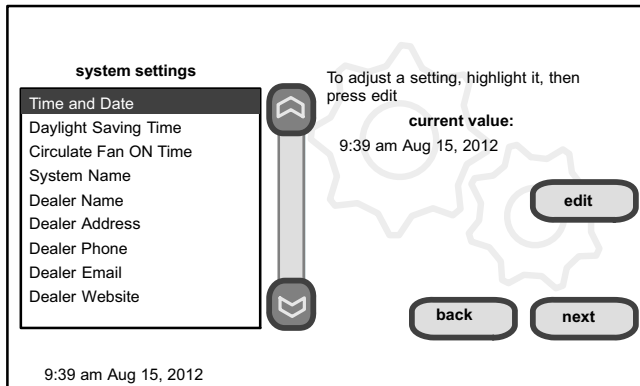

Figure 2. "System settings" screen

Change settings

If you want to change a setting, use one of the *Settings change tools* shown

in figure 3. (Also, see **Set time and date** on Page 7.) After changes have been made, use **save** to store the changed data or **cancel** to exit the screen and return to the list of settings.

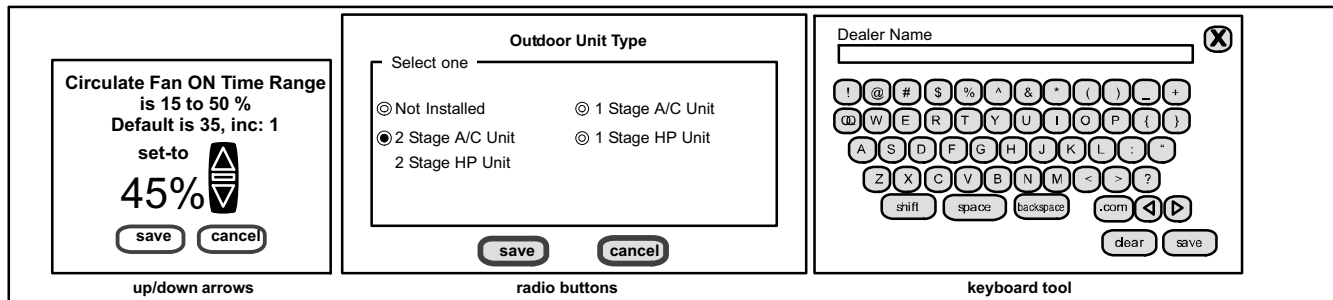

Figure 3. Settings change tools

Circulate fan ON time setting



NOTE - If the circulate fan mode is on, a timer is set to measure all the time that the fan is blowing, regardless if it is running to deliver heating or cooling or just for circulation.

“Circulate” is enabled on the user’s **home** screen or **system settings** page. It keeps air circulating from 15% to 50% percent of time. The following settings approximate how long the fan will run at these typical settings:

- 15% (9 minutes fan run time per hour)
- 25% (15 minutes fan run time per hour)
- 35% (21 minutes fan run time per hour)
- 45% (27 minutes fan run time per hour).

Table 1 shows the range/condition and defaults for the system settings and indicates the tools used to make changes.

Table 1. System setting defaults and range

system setting	range/condition	default	use
Time and Date	see Page 7		
Daylight Saving Time	Enabled/Disabled	Enabled	 
Circulate Fan ON Time	15 to 50% (in 1% increments)	35%	
System Name	(alpha-numeric characters)	—	use keyboard tool to change
Dealer Name	(alpha-numeric characters)	your dealer	use keyboard tool to change
Dealer Address		—	
Dealer Phone		1-800-448-5872	
Dealer Email		—	
Dealer Website		—	

Set time and date

Use the arrows to select **Time and Date**; press **edit** (see figure 4) to proceed to the "Set current time and date" screen (figure 5).

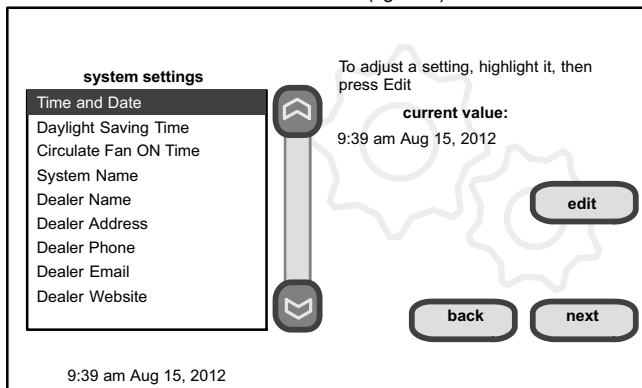
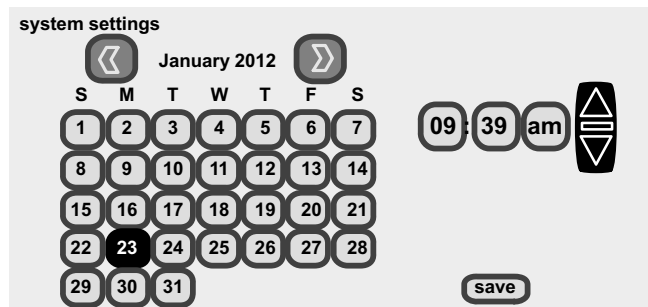

Figure 4. View/edit time and date

When "Time and Date" screen (figure 5) appears, enter the correct date as follows:

- Use the left and right arrows to change the month and year.
- Touch a day of the month to select it.
- Press on the hour or minute; up down arrows appear to allow change.
- Touch the **am/pm** field to toggle it between am and pm.
- When the correct date and time is set, press **save** to save settings and return to previous settings screen.

Touch **next** to continue to next screen.



9:39 am Aug 15, 2012

Figure 5. Set current time and date

Use “about” screen & access “Add or Remove Non-communicating equipment” screen

The “about” screen shows details of discovered installed equipment.

From the “system devices” screen, use arrow buttons to scroll to a device; then press the **about** button. Use the up/down arrows to scroll through and view additional information about the selected device. When finished viewing, press the **back** button.

Press **next** to advance to the “Add or Remove Non-communicating equipment?” screen.

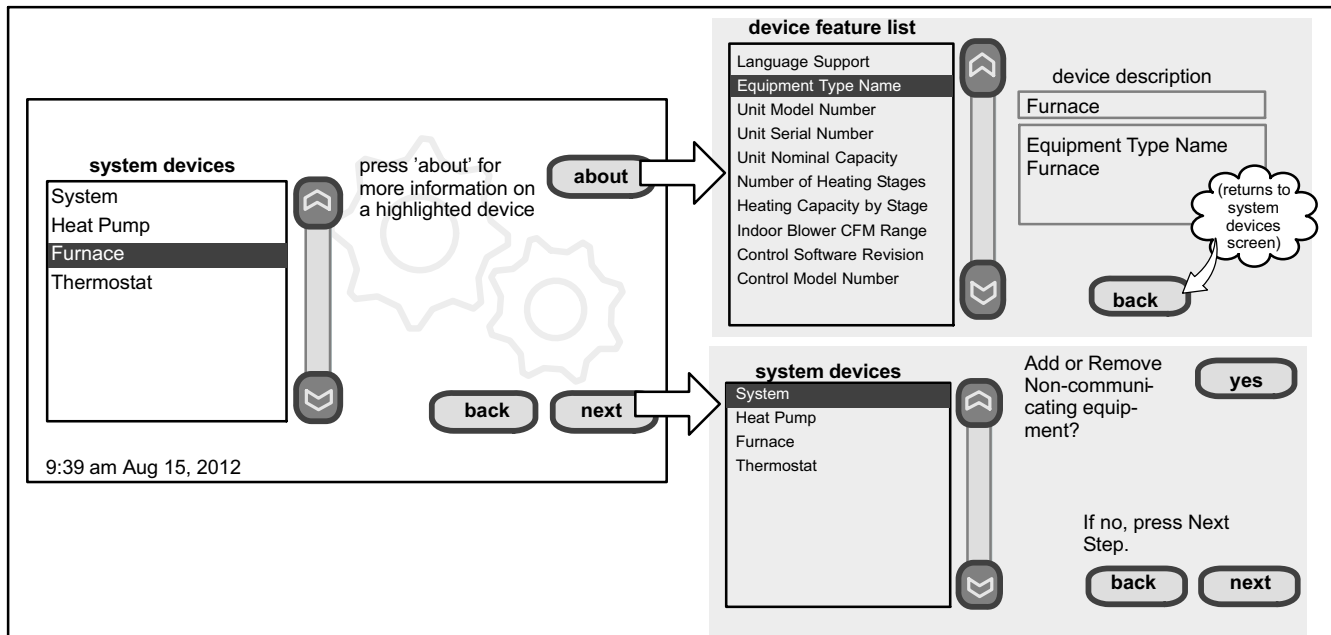

Figure 6. “About” & “Add or Remove Non-communicating equipment” screens

Add or Remove Non-communicating equipment

Figure 6 (previous page) shows how to access the “Add or Remove Non-communicating equipment” screen.

Adding Non-Communicating Outdoor unit—See figure 7 for details for adding/removing an outdoor unit.

Adding Humidifier—The procedures in figure 8 describe adding a non-communicating humidifier which will be controlled by the Comfort Sync™ thermostat through the “H” or “HUM” terminals on the furnace or air handler.

Adding Dehumidifier—The procedures in figure 9 describe adding a non-communicating dehumidifier controlled by the Comfort Sync™ thermostat through the “DH” output on the furnace or air handler.



NOTICE

For details about how the humidification and dehumidification modes operate and how to configure those modes, see additional information beginning on Page 18.

HUMIDITY CONTROL TIPS

- The standard humidification mode is “Basic” (humidifier is energized during a call for heat, if there is a humidification demand).
- Sensed outdoor temperature, required for some features, is provided from one of the following sources:
 - A** downloaded via Wi-Fi when available (primary source),
 - B** sensor furnished with Comfort Sync-enabled outdoor units,
 - C** separate outdoor sensor connected to the furnace or air handler “outdoor sensor” connections.

NOTE - If no source for outdoor temperature is present, “Basic and Precision Dew Point Control” modes are not available.

- If you do not have the ability to select or adjust the Humidity RH set-point on the “Indoor Humidity” button, the control is set for “Display Only.” In the installer program, go the **equipment** button and select “System” and press the **edit** button. Select “Humidification Control Mode” and press **edit**. Choose “Basic,” “Precision,” “Basic Dew Point Control” or “Precision Dew Point Control” and press **save**.

Adding non-communicating accessories—Adding maintenance timer reminders to accessories is a simple process of “installing” the device, which effectively tells the thermostat to activate access to its service timers. Timers are available for two (2) filters, Humidifier pad and UV bulb maintenance.

Add Non-Communicating Outdoor unit

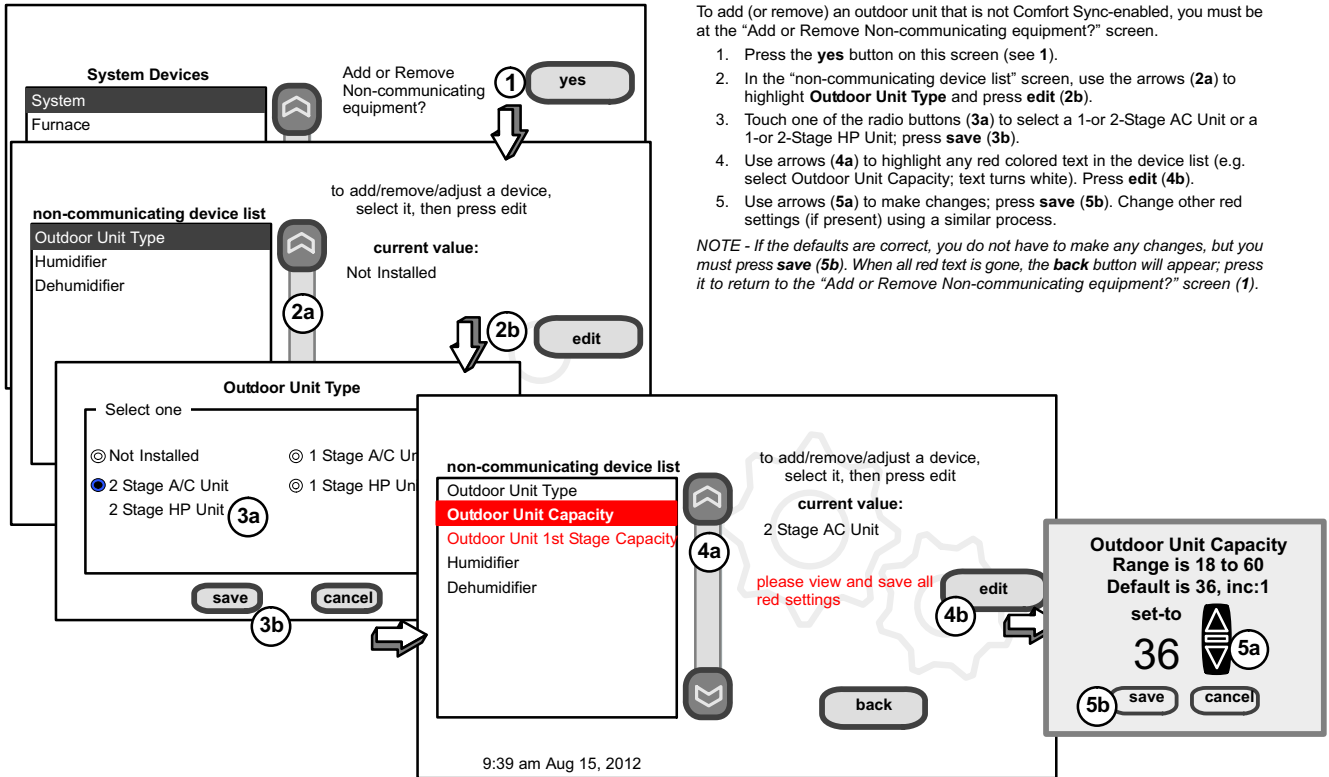

To add (or remove) an outdoor unit that is not Comfort Sync-enabled, you must be at the "Add or Remove Non-communicating equipment?" screen.

1. Press the **yes** button on this screen (see 1).
2. In the "non-communicating device list" screen, use the arrows (2a) to highlight **Outdoor Unit Type** and press **edit** (2b).
3. Touch one of the radio buttons (3a) to select a 1-or 2-Stage AC Unit or a 1-or 2-Stage HP Unit; press **save** (3b).
4. Use arrows (4a) to highlight any red colored text in the device list (e.g. select Outdoor Unit Capacity; text turns white). Press **edit** (4b).
5. Use arrows (5a) to make changes; press **save** (5b). Change other red settings (if present) using a similar process.

*NOTE - If the defaults are correct, you do not have to make any changes, but you must press **save** (5b). When all red text is gone, the **back** button will appear; press it to return to the "Add or Remove Non-communicating equipment?" screen (1).*

Figure 7. Add non-communicating device—OUTDOOR UNIT

Add (or Remove) Humidifier *(skip if no humidifier is being used)*

Before adding a humidifier, be sure that:

- the humidifier is wired to the furnace or air handler control as shown on the Optional Accessories wiring diagram (see Page 61),
- the entire system is wired, powered up, and the thermostat has detected the system's installed communicating devices, and you are at the "Add or Remove Non-communicating equipment?" screen (see figure 6, Page 8).

NOTE - Adding humidity regulating non-communicating devices may be a 2-step procedure: **1st**, the device must be installed (this page; after the humidifier is installed, the operation mode defaults to "Basic").

2nd, (if you want another mode, i.e. Precision, Basic Dew Point, or Precision Dew Point, the device requires further configuration (see Page 15).

To add (or remove) a humidifier,:

- Press the **yes** button on this screen (see 1).
- In the "non-communicating device list" screen, use the arrows (2a) to highlight **Humidifier** (note the current value, **Not Installed**) and press **edit** (2b).
- Touch one of the radio buttons (3a) to select the type of humidifier (or select **Not Installed**, if removing humidifier); press **save** (3b).
- The previous screen returns, but the current value now shows your selection (4a). Press the **back** (4b) button.
- The "Add or Remove..." screen reappears with your addition shown in the system devices list (5a). At this point, you may add more equipment (press **yes**) or if finished, press the **next** (5b) button to advance to the "Adjust a setting..." screen (see page 15).
- (If you want other than the default "Basic" mode of operation)** Configure the humidifier as described on Page 15.

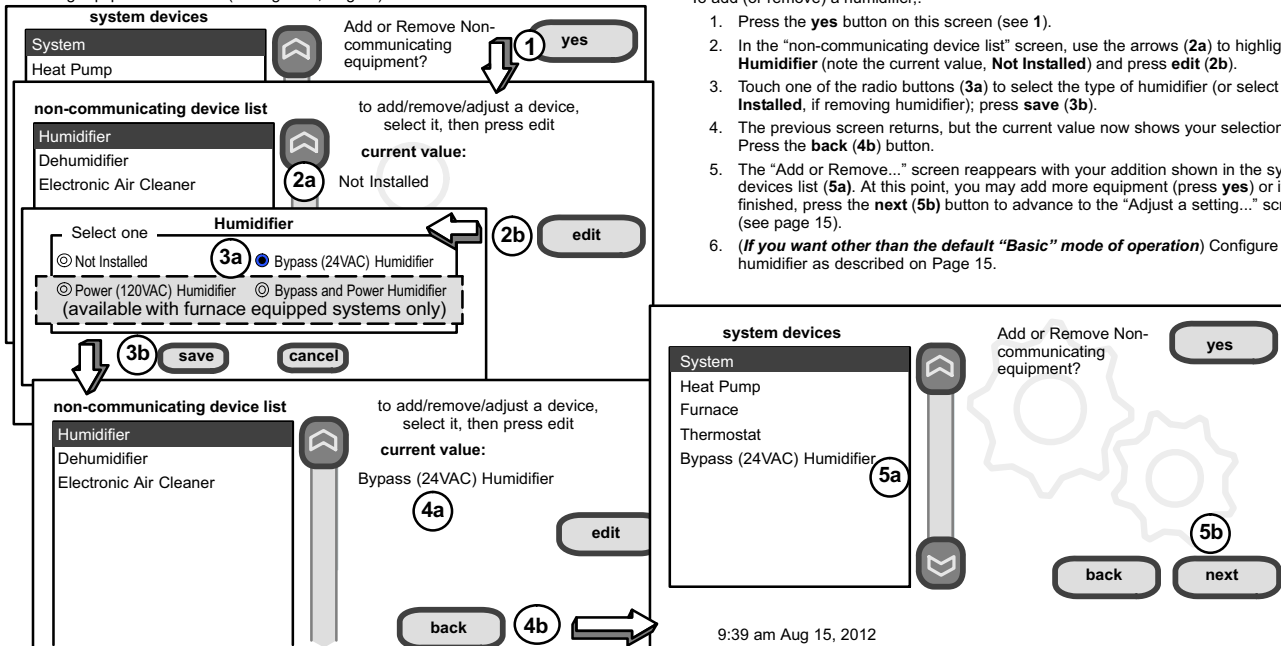

Figure 8. Add or remove non-communicating device—HUMIDIFIER

Add (or Remove) Auxiliary Dehumidifier (skip if no dehumidifying device is being used)

Before adding a dehumidifier, be sure that:

- the dehumidifier is wired to the furnace or air handler control as shown on the Optional Accessories wiring diagram (see Page 61),
- the entire system is wired, powered up, and the thermostat has detected the system's installed communicating devices, and you are at the "Add or Remove Non-communicating equipment?" screen (see figure 6, Page 8).

NOTE - Adding humidity regulating non-communicating devices may be a 2-step procedure: 1st, the device must be installed (this page; after the dehumidifier is installed, the operation mode defaults to "Basic"). 2nd, set the min/max dehumidification setpoints if desired (see Page 16).

To add (or remove) a dehumidifier, you must be at the "Add or Remove Non-communicating equipment?" screen.

- Press the **yes** button on this screen (see 1).
- In the "non-communicating device list" screen, use the arrows (2a) to highlight **Dehumidifier** and press **edit** (2b). Note the current value (e.g. Not Installed).
- Touch one of the radio buttons (3a) to select the type of dehumidifier (or select **Not Installed**, if removing dehumidifier); press **save** (3b).
- When you scroll to the Dehumidifier device (4a), (Note the current value, e.g. Aux. Dehumidifier.) Click **back** (4b) to return to the "Add or Remove..." screen (1).
- The "Add or Remove..." screen reappears with your addition shown in the system devices list (5a). At this point, you may add more equipment (press **yes**) or if finished, press the **next** button (5b) to advance to the "Adjust a setting..." screen (see Page 13).

Note—By default, the minimum dehumidification setpoint of 40% RH. If these settings are satisfactory, no further configuration is necessary. If another setting is needed, change setpoint as described on Page 16.

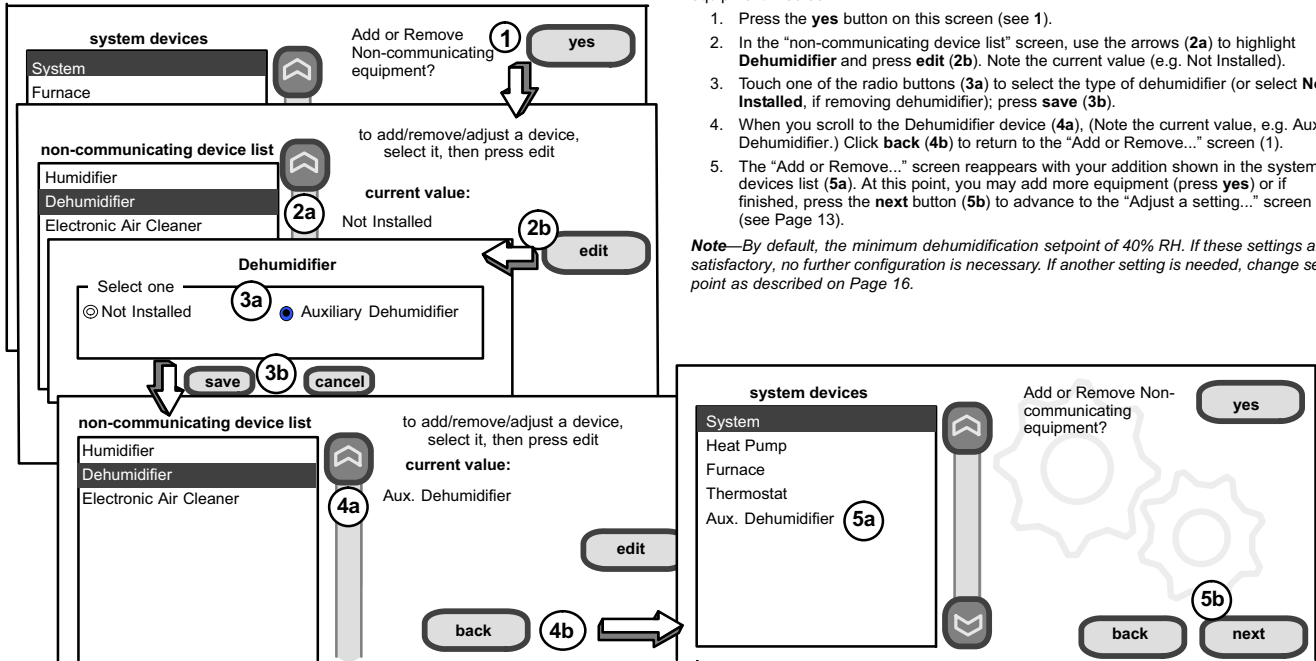

Figure 9. Add or remove non-communicating device—DEHUMIDIFIER

Adjust a setting screen (communicating devices)

Use arrows to select a device from the “system devices” list; then use the **about** button to view information (shown on Page 8) about **communicating** devices (information about other devices is not available).

Use **resetAll** button to un-install all non-communicating devices that were added through “Add or Remove...” screen and to reset any device settings made through this “Adjust a setting...” screen to the factory defaults. (While editing a communicating device, the **reset** button is limited to only the selected device. You are asked to **confirm** (shown in figure 10) before resetting all.

Use this screen to access communicating devices’ settings (pressing buttons numbered from 1 to 6 in figure 10 for an example of changing heating airflow; more examples are shown on the next page). Use **back** to return to the previous screen or **next** to go on. A complete list of parameters, their defaults and setting ranges, begins on page 37.

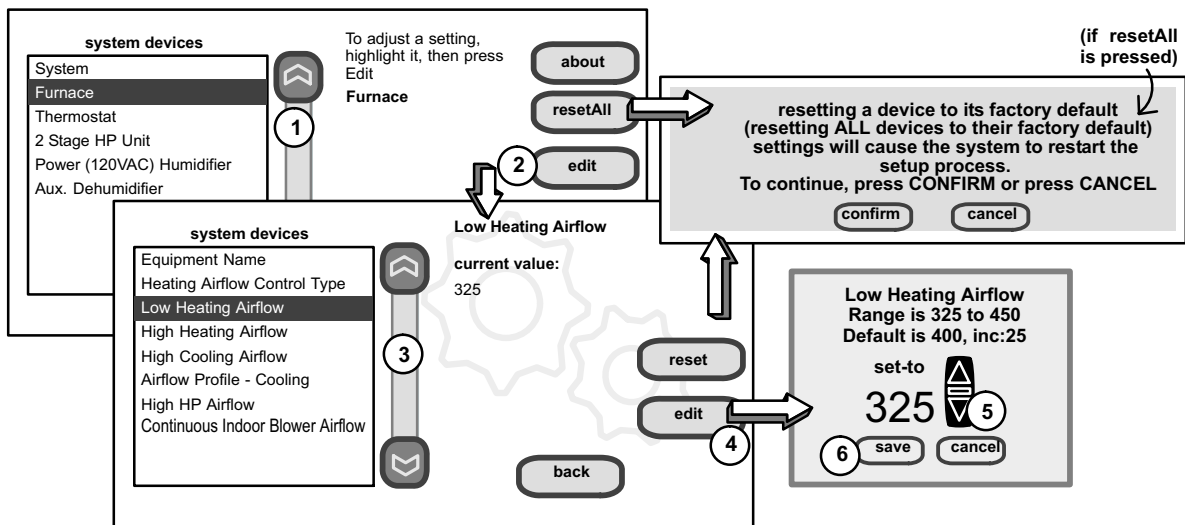

Figure 10. Adjust communicating device screens

Use the up/down arrows to scroll through the device's settings. The current setting will be displayed on the right-hand side of the screen (figure 11). For example, **current value: disabled**. Press **edit** if you want to modify that setting, or press **back** to return to the previous screen.

Available settings for the devices depend on the installed components. Shown below is an example of enabling and changing the balance point control from default (Disabled) to Enabled. After selecting **Enabled**, press **save** to save the changes and return to the previous screen.

The returning screen may appear with the message in red "please view and save all red settings." In the example in figure 12, note that two additional items are listed in red. Use the arrows to scroll and highlight each item appearing in red. Press **edit**, make any desired changes, and press **save**.

When all affected settings have been edited/saved, the red message disappears. Press back to return to the "To adjust a setting..." screen.

If no more adjustments are necessary, press **next** to advance to the "select tests to run" screen (see Page 19).

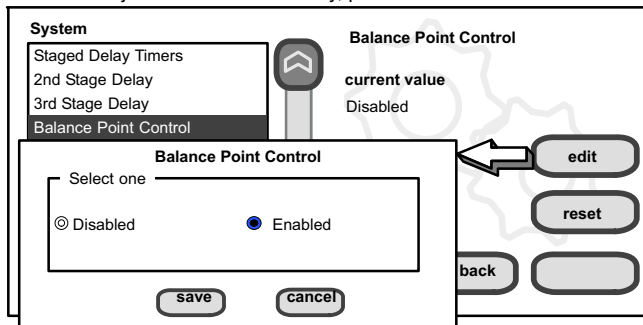

Figure 11. Accessing device to modify

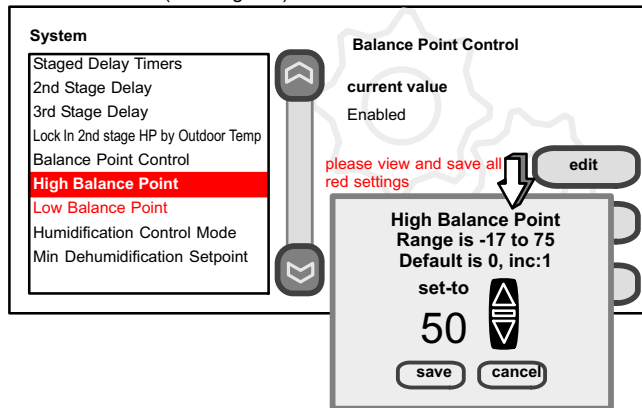

Figure 12. Modify device settings

A97MV Furnace Note:

If your ComfortSync™ thermostat is being used with a n A97MV furnace and is set to variable-capacity mode of operation (the Comfort Sync default with these units), the thermostat's settings for stage timers are ignored (even if shown enabled in the thermostat). The stage timer will be used on the cooling side. The furnace software sets and controls the firing rates. The only other controlling factor is the stage temperature differentials. In Load-Tracking Variable Capacity (default for these furnaces), both stage timers and temperature differentials are ignored.

Adjust a setting... Configure Humidifier (skip if no humidifier is being used or if humidifier is being used and default "Basic" humidification mode is desired)

To adjust a setting, highlight it, then press Edit

System Devices

System
Air Conditioner
Furnace
Thermostat
Power (120VAC) Humidifier

1a

System

about

edit

1b

Humidification Control Mode

current value: Basic

2nd Stage Differential
Staged Delay Timers
2nd Stage Delay
Dehumidification Control Mode
Humidification Control Mode

2a

edit

2b

Humidification Control Mode

Select one

- Display Only
- Precision
- Precision Dew Point

3a

Basic

Basic Dew Point Control

save

cancel

3b

System

1st Stage Differential
2nd Stage Differential
Staged Delay Timers
2nd Stage Delay
Dehumidification Control Mode
Humidification Control Mode
Max Humidification Setpoint
OK/Humid Boundary
Outdoor Temperature Reading

4a

Max Humidification Setpoint

current value: 45

please view and save all red settings

edit

reset

back

(returns to adjust a setting... screen)

Max Humidification Setpoint

Range is 15 to 45

Default is 45, inc:1

set-to

45

5a

5b save cancel

9:39 am Aug 15, 2012

Pre-adjustment REQUIREMENTS:

1st, the device has been **installed** (see Page 11).

2nd, you pressed **next** at the "Add or Remove..." screen (see Page 11).

Configure the device as follows:

1. In the "system devices" list, use the arrows (1a) to highlight **System**. Press **edit** (1b).
2. In the "System" list, use the arrows (2a) to highlight **Humidification Control Mode**. The current value defaults to Basic mode. Press **edit** (2b).
3. Touch one of the radio buttons (3a) to select the mode of humidification control; press **save** (3b). (After saving, check that the current value now shows the new selection).
4. Use arrows (4a) to highlight any red colored text in the list (e.g. select **Max Humidification Setpoint**). Press **edit** (4b).
5. Use arrows (5a) to make changes; press **save** (5b). Repeat for other red settings. **You will not be able to advance to the next step until all red settings have been removed..**
6. Press the **back** button to return to "Adjust a setting..." screen.

NOTE - If the defaults for the settings shown in red, you are not required to make any changes, but you must go into the edit tool, and press **save** (5b). When all red text is gone, the **back** button will appear; press it to return to the "Adjust a setting..." screen.

Figure 13. Adjust a non-communicating device setting—HUMIDIFIER

Adjust a setting... Configure Auxiliary Dehumidifier

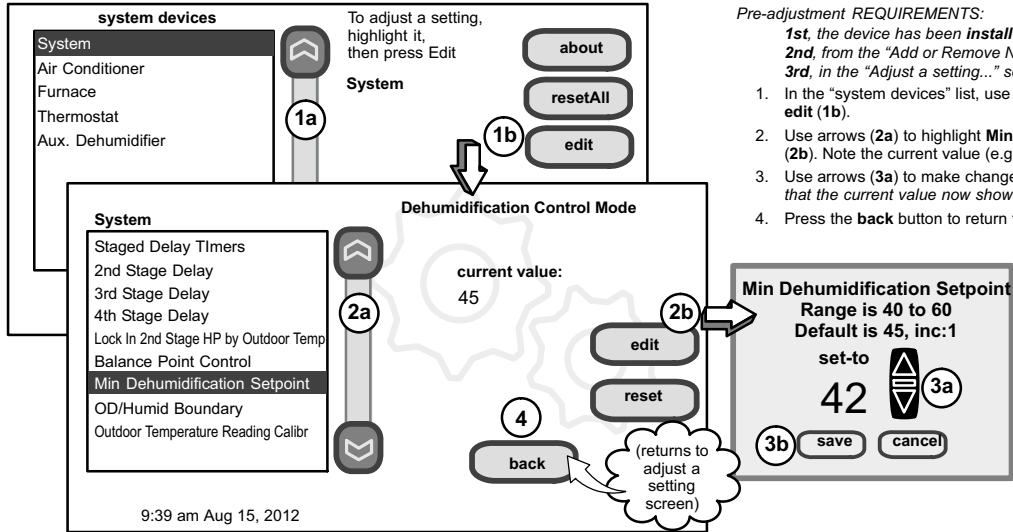

Pre-adjustment REQUIREMENTS:

1st, the device has been **installed** (see Page 12).

2nd, from the "Add or Remove Non-communicating equipment?", press **next**.

3rd, in the "Adjust a setting..." screen, configure the device as follows:

1. In the "system devices" list, use the arrows (1a) to highlight **System**. Press **edit** (1b).
2. Use arrows (2a) to highlight **Min Dehumidification Setpoint**; press **edit** (2b). Note the current value (e.g. 45).
3. Use arrows (3a) to make changes; press **save** (3b). (After saving, check that the current value now shows the new selection).
4. Press the **back** button to return to "Adjust a setting..." screen.

Figure 14. Adjust a non-communicating device setting—DEHUMIDIFIER

Adjust a setting... Configure Dehumidification (no dehumidifying device installed) (skip if default "Basic" dehumidification mode is desired)

To adjust a setting, highlight it, then press Edit

System Devices

- System
- Furnace
- Thermostat
- 2 Stage AC Unit
- Power (120VAC) Humidifier

System

- 2nd Stage Differential
- Staged Delay Timers
- 2nd Stage Delay
- Dehumidification Control Mode
- Humidification Control Mode
- OK/Humid Boundary
- Outdoor Temperature Reading

Dehumidification Control Mode

current value:
Display Only

Select one **Dehumidification Control Mode**

- Display Only
- Precision
- Basic

System

- Staged Delay Timers
- Balance Point Control
- Dehumidification Control Mode
- Humidification Control Mode
- Auto Changeover - Humidif. Deadband
- Max Humidification Setpoint
- Min Dehumidification Setpoint**
- OK/Humid Boundary
- Outdoor Temperature Reading

Dehumidification Control Mode

current value:
Precision

please view and save all red settings

Min Dehumidification Setpoint

Range is 40 to 60
Default is 45, inc:1

set-to
45

9:39 am Aug 15, 2012

Pre-adjustment REQUIREMENTS:

- 1st, **NO** physical dehumidification device has been installed.
- 2nd, configure the thermostat for dehumidification as follows:
 1. In the "system devices" list, use the arrows (1a) to highlight **System**. Press **edit** (1b).
 2. In the "System" list, use the arrows (2a) to highlight **Dehumidification Control Mode**. The current value defaults to Display Only. Press **edit** (2b).
 3. Touch one of the radio buttons (3a) to select the mode of dehumidification control; press **save** (3b).
 4. Use arrows (4a) to highlight any red colored text in the list (e.g. select Min Dehumidification Setpoint). Press **edit** (4b).
 5. Use arrows (5a) to make changes; press **save** (5b). Change other red settings (e.g. Auto Changeover - Humidif. Deadband) using a similar process.
 6. Press the **back** button to return to "Adjust a setting..." screen.

NOTE - If the defaults are correct, you do not have to make any changes, but you must press **save** (5b). When all red text is gone, the **back** button will appear; press it to return to the "Add or Remove Non-communicating equipment?" screen.

Figure 15. Adjust dehumidification when not using an auxiliary dehumidifier

Humidification and Dehumidification Modes—how they work

HUMIDIFICATION modes

BASIC & PRECISION—These modes allow user control of RH between 15 and 45%. These conditions must be met for either mode to operate:

- humidification mode has been enabled, and
- the unit is in HEAT mode, and
- humidification demand exists (24V present at H), and
- **BASIC** mode also requires presence of heating demand [Y for HP heat, or W for gas heat (W may be energized with G de-energized)].

DEW POINT—(Available only if Wi-Fi is operational or outdoor sensor is attached)

Basic Dew Point Control—Basic Dew Point Control adjustment mode will change the humidification setpoint based on the outdoor temperature and a user-defined dew point adjustment setting.

Precision Dew Point Control—Precision Dew Point Control adjustment mode will operate when these conditions are met:

- humidification mode has been enabled, and
- the unit is in HEAT mode, and
- humidification demand exists (24V present at H).

DEHUMIDIFICATION modes

NOTE - Basic and Precision dehumidification modes are functions of the HVAC system with NO external dehumidification devices installed. Auxiliary Dehumidifiers do not use these modes.

In **BASIC** mode, dehumidification occurs if these conditions are met and signals are present at specific terminals:

- dehumidification has been enabled on installer settings, and
- the unit is in COOL mode, and
- dehumidification demand exists (RH above setpoint), and
- cooling demand exists (Y1 energized).

In **PRECISION** mode, dehumidification occurs if all BASIC conditions are true, except cooling demand may or may not be present. Also note that:

- **Maximum overcool from cooling setpoint is 2°F.**
- **Deadband** temperature is limited to 5°F. (instead of 3°F in **BASIC** or **DISPLAY ONLY** mode) because of 2°F overcooling.

Auxiliary Dehumidifier mode requires:

NOTE - Systems using Comfort Sync and a dehumidifier - "Dehum" jumper on furnace/air handler control does not need to be cut when using with a Comfort Sync™ thermostat.

- Wi-Fi is operational or outdoor sensor is installed and set up
- dehumidification has been enabled on installer settings, and
- the unit is in COOL mode, (or if in AUTO, at least one thermostat cooling call made prior to the dehumidification demand), and
- a dehumidification demand exists (RH above setpoint), and
- outdoor temp. below 95°F; indoor temp. above 65°F, and

Auxiliary Dehumidifier NOTE

When an auxiliary dehumidifier is used, dehumidification will be allowed under the following conditions, provided **there is NO call for humidification**:

- In the absence of heating or cooling calls, or
- Simultaneous with blower only calls.

If the blower is required to operate while the auxiliary dehumidifier is running, a separate wire must be installed from the auxiliary dehumidifier to the indoor unit's G thermostat input that will energize G when the auxiliary dehumidifier is running (see wiring diagram on Page 61).

Auxiliary dehumidification is controlled by the thermostat dehumidification demand.

NOTE - Refer to the Auxiliary Dehumidifier Installation Instructions for installation recommendations.

Use the Tests / Diagnostics features

NOTE - Test mode lasts for 30 minutes (with the temperature updating every 30 seconds) except for the defrost test, which lasts 30 seconds. Tests feature provides the technician time to manually verify the equipment operation.

The **tests** feature is available after **setup** has been completed once. After you press **next** in the final **setup** screen, the “select tests to run” screen (figure 17) will appear. (If you want you may skip tests; press **skip tests**.)

If you re-select the **tests** button from the full option screen (figure 16), a message to “press Start button below to begin system testing” appears. Press **start**. The resulting screen will be identical to figure 17.

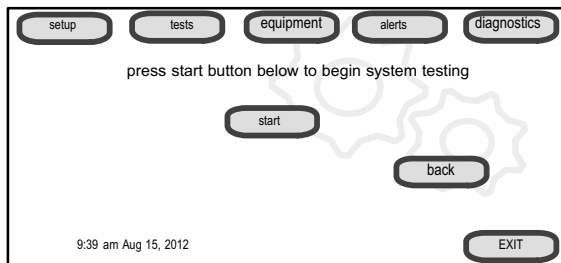

Figure 16. Start testing screen

To run all of the tests, press **select all**. All boxes in the list of tests will be checked. Or, touch box(es) next to test(s) to run certain tests.

After the tests have been started, the screen will describe which test is running and shows a diagnostic summary of each test (see figure 18). After reviewing the results and concluding that no further tests are needed, press **next** to proceed to next test. The technician must verify that the test procedure is producing the desired result at the equipment.

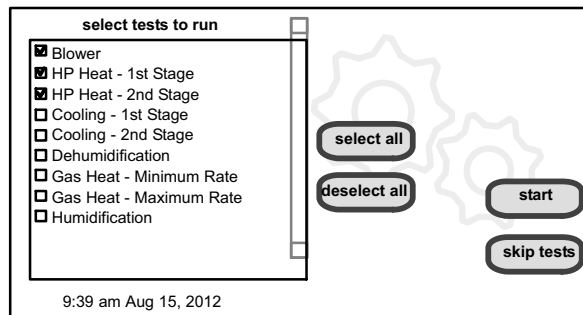

Figure 17. Select tests to run screen

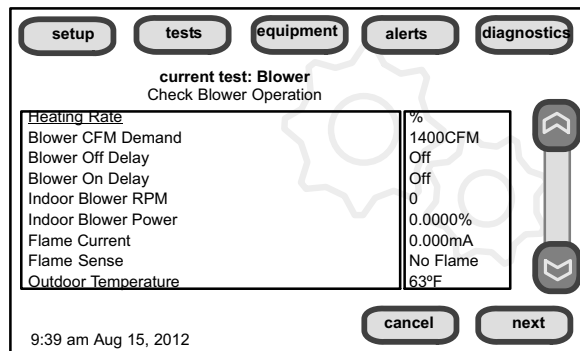

Figure 18. Typical tests results screens

After pressing **next** after the final test, the “Testing finished” screen will appear (figure 19). At this point, use the **EXIT** button (if you have completed the required setup), or use **diagnostics** button (to analyze the system), or use **equipment** button (if you wish to make any changes to device details).



Figure 19. Testing finished screen

Equipment, Alerts, Diagnostics

Press **equipment** if you need to set up equipment parameters and edit details of devices in the system (see Page 20).

Press **alerts** if you need to run to see any alerts that may present or to view alerts that have been cleared (see Page 22).

Press **diagnostics** if you need to run to analyze the system (see Page 21).

Set up Equipment parameters

Press **equipment** to set up equipment parameters and edit details of devices in the system without having to re-run the setup program. When the “press start...” screen (figure 20A) appears, press **start**. The “Equipment parameters” screen (figure 20B) will open. You may view information about or modify communicating devices as described earlier in the setup pages, beginning on page 14. Use the arrows to select a device and press **edit**.

Use the arrows to highlight a setting and then press **edit** (figure 21A). In the example, the low heating airflow is changed from the default (400) to 325 (figure 21B). After changing, press **save**. (note the current value has changed; figure 21C). Some changes may affect other settings and, if so, those affected will appear in red and require changing/saving to clear the red settings.

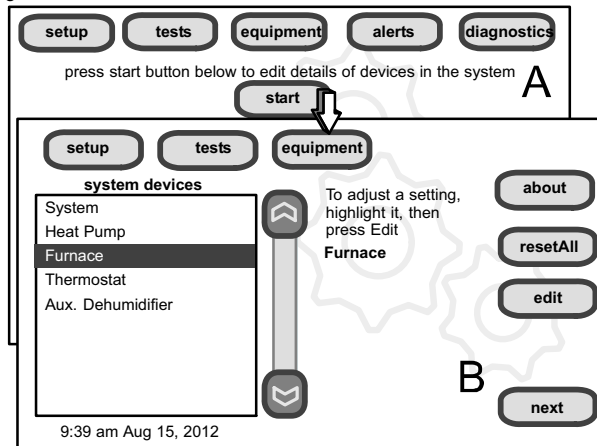

Figure 20. Equipment parameters screen

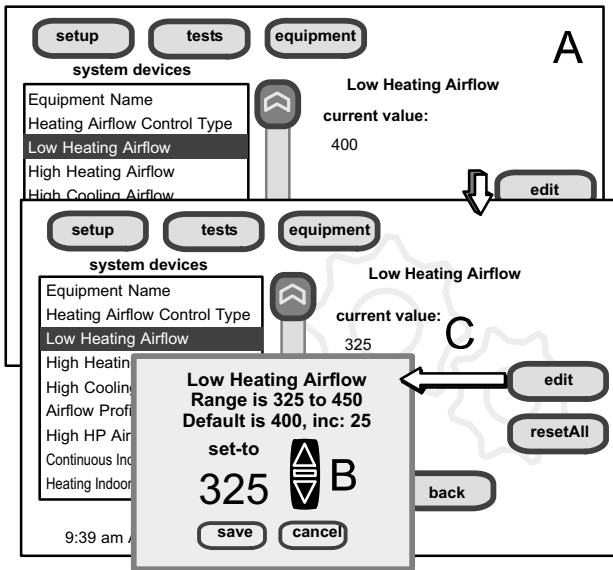

Figure 21. Edit equipment details

When finished, press **back**; equipment parameters screen (figure 20B returns); then press **next**. “Select tests to run screen appears” (Page 19); either run tests as before or press **skip tests**.

The “Testing process screen” (see figure 19) again appears; use the **EXIT** button (if you have completed the required setup), or use **diagnostics** button (to analyze the system; see Page 21), or use **equipment** button again (if you want to make any further changes to device details).

Table 3 on (on Page 37) shows a list of Editable Parameters for the currently available devices designed to communicate in this system. Other devices and additional parameters may be added at a later time. Check the unit installation manuals (i.e. furnace, air handler, heat pump, ac unit) for current information and default parameters.

Run Diagnostics

NOTE - To run diagnostics and insure the system works properly, the system should be running—set the thermostat so that it will initiate a demand for cooling, heating, dehumidification, humidification, or continuous fan operation.

If you need to run diagnostics to analyze the system, press the **diagnostics** button. The “select a device” list (figure 22A) will open.

Use the arrow buttons to scroll through the list of items found on the left of the screen. The right side of the screen shows which item is selected. Use **start** to begin the process. A “waiting” message displays while the diagnostics are being conducted, followed by a screen similar to figure 22B.

Use the arrow buttons to scroll through the information and take note of any found to be out of operating range.

Press **done** when finished with the information. Select another device to diagnose or use **EXIT** (to close and go to user Home screen) if finished.

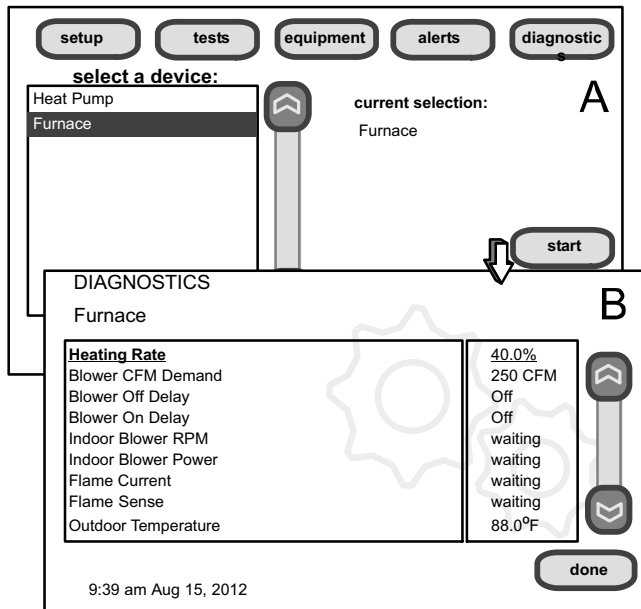

Figure 22. Select device and run diagnostics

View and clear Installer Alerts

NOTE - Service alerts remind users to service filters, humidifier pad and UV light and are not shown in the installer's menu.



From the user's home screen, press and hold the "Swoosh" logo in the bottom right corner of the thermostat to access the installer program. Press **yes** when asked if you want to proceed. The installer screen opens at the "system and device alerts" screen (figure 23A).

The left side of the "system and device alerts" screen shows a list of each communicating device discovered in the system and check boxes for selecting each device. Or, you may use buttons to the right of the System Devices list to **select all** (or **deselect all**). After something has been selected; use **view active** to list all active alerts for selected devices. If there are no alerts, the display will show "There are no new alerts that require service". If there are alerts, these are stored for recall but only one alert will appear in the box at a time (see figure 23B). Use the **next** button to advance through all the alerts. If only one alert is present, the **next** button will not appear.

Alerts may pop up on the screen during setup. Details of all active alerts can only be accessed through the installer's screens. To view all alerts present at any time, press the **alerts** button. "System setup / Diagnostics is complete" (figure 23B) appears; close it and the "Select devices to view alerts screen (figure 23A) appears.

Use **view cleared** alerts to list previously active alerts that were cleared by the device or installer. Until at least one alert has been cleared by the device or the installer, the message "There are no new alerts that require service" will be displayed.

The first alert will be displayed in the alert screen (figure 23B), in order of:

1.  red alert icon
2.  yellow alert icon (service)

A **red alert icon** identifies a system or device issue that can prevent the system from working properly or at all, and if allowed to run, could cause damage to the system. **The issue raised by the alert must be addressed and corrected before clearing the alert!**

Press **clear** (figure 23B) to clear a red alert. The alert will be stored in the "cleared alerts" file. If an alert cannot be cleared, revisit the alert issue and make repairs accordingly.

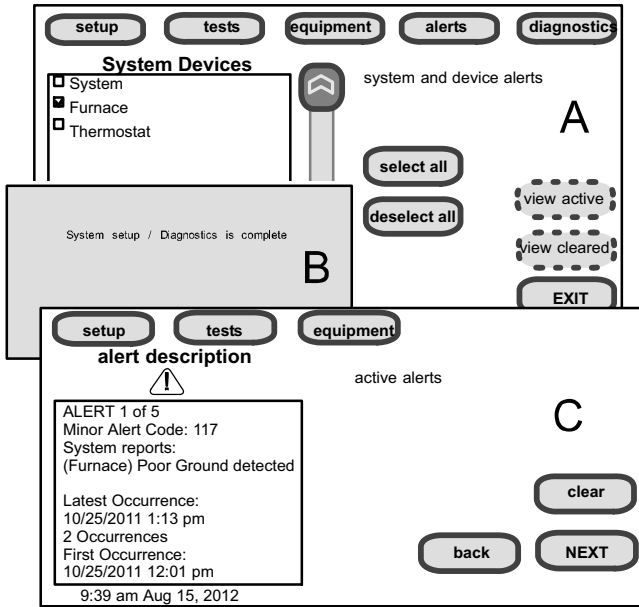

Figure 23. Selecting and viewing alerts

After all active alerts have been cleared, only the back button remains and the alerts box shows "No Alerts" (Figure 24).

Press **back** to return to the system and device alert screen (figure 23A, Page 23).

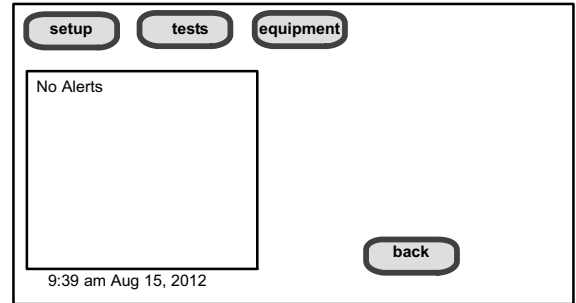

Figure 24. Cleared alert confirmation

View cleared alerts

A history of cleared alerts allows the installer to review cleared alerts. This information can help diagnose problems. Use the arrows to **select all** or check an item from the list and then press **view active alerts**. Then, scroll through the alerts using the **next** button.

Press **back** to return to the alerts screen (figure 23A, Page 23).

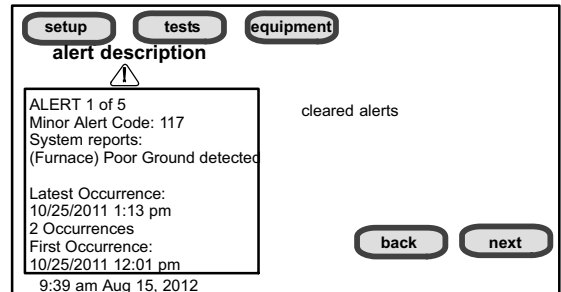

Figure 25. Cleared alerts screen

Registering the Comfort Sync™ thermostat

From NETWORK SETTINGS screen, you can change to the desired network as shown in figure 27. Enter security key or passphrase. "X" back to the WI-FI SETTINGS screen.

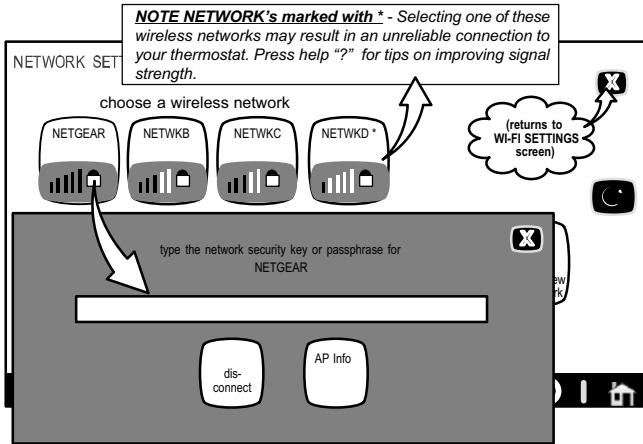

Figure 27. Change Networks

Registration for online access

From the WI-FI SETTINGS screen, press the "thermostat not registered" button (see figure 28).

Enter homeowner email address twice and press the **register** button.

A pop up screen then appears to notify the user to check their home computer for instructions to complete the registration. After the server sends the email with the network link, registration and account creation must be completed on the homeowner's personal computer (see Page 26).

NOTE - Time from pushing the registration button on the thermostat and receiving the consumer portal register link from your email on your computer is from 5 to 15 minutes.

After registration has been completed, any available firmware downloads will immediately start downloading to the thermostat.

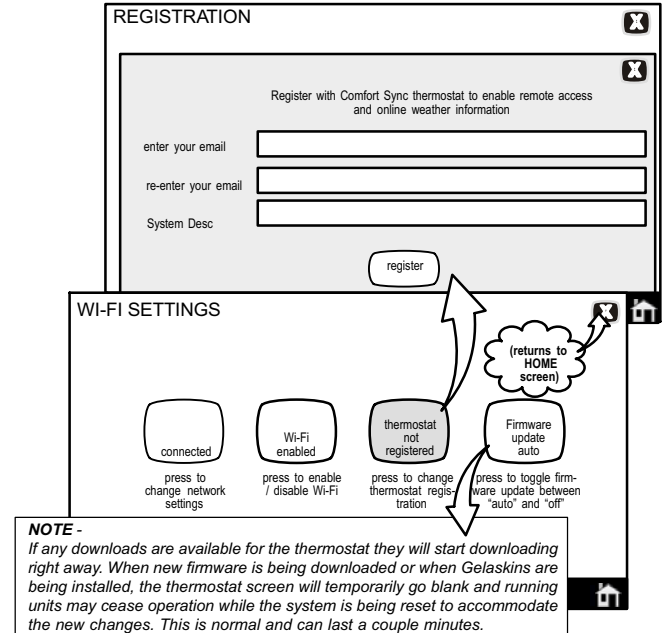

Figure 28. Registering the system for online access

For any issues with Wi-Fi connections, refer to Wi-Fi Troubleshooting Checklist 507094-01.

Personal Computer account registration for Comfort Sync™ server

The screenshot shows a web interface for a Comfort Sync account. At the top, there is a dark blue header with the 'COMFORT SYNC' logo on the left and 'Dashboard', 'Log Out', and 'Help' links on the right. Below the header is a navigation bar with three tabs: 'My Profile' (selected), 'My System', and 'My Dealer'. The main content area is light gray and contains a welcome message: 'Welcome Sundar Natarajan! Update your profile using the form below.' Below this is a registration form with several input fields, each with an asterisk indicating it is required. The fields are: '*First Name', '*Last Name', '*Phone', 'Mobile Phone', '*Primary Email', and 'Password'. The email and password fields have placeholder text and links for 'Change Email' and 'Change Password' respectively. At the bottom of the form, there is a note: '* indicates a required field'.

NOTE - This following information is customer setup instructions and is shown here to allow the installer to help walk the customer through the setup process.

NOTE - if the customer has already setup an account, click the "Click Here" button to access that account.

After registering through your Comfort Sync™ thermostat interface, go to the homeowner's computer and locate the email sent from the server:

Dear Customer,

Congratulations on your purchase of an Allied Comfort Sync thermostat! You are only a few steps away from total control of your Comfort Sync system. Registering your thermostat will allow you to remotely access it from anywhere in the world on any device with an internet connection. Please complete your Comfort Sync registration by clicking the link below:

[Register](#)

Click on the Register link; the screen (to the left) will appear. Fill in the User Name and Password fields and check the agree to terms and conditions box. Click **Create User** button.

A series of pages and prompts follows to provide guidance through profile setup and user preference definitions.

Figure 29. Computer login for online access



Figure 30. PC Welcome Screen

Welcome home.

Access all the great Wi-Fi enabled features on your Comfort Sync™ thermostat from our secure web portal. After signing in, you'll be able to view your Comfort Sync system settings, adjust the temperature and view reminders and alerts – just as you would on your Comfort Sync™ thermostat at home. With a familiar look and settings this simple, you should feel right at home. Don't forget to check out the available Apps and customizable skins using the links on the right side of the page. From the welcome page, you may also click on links to launch an interactive demo or learn more about Comfort Sync.

How Do I Turn on Skins on the Comfort Sync™ Thermostat?

From the thermostat **Home** screen, press **⏏** then **display setting** then **power save** buttons. From the popup menu, select **skins**. The skin picture will appear after 30 seconds of inactivity.

How Do I Upload a Skin?

Skins should be ordered from www.gelaskins.com/comfortsync. After ordering the skin, Gelaskins will email the image file (.jpg) to the homeowner. This ".jpg" has been altered to display correctly on the Comfort Sync™ Thermostat. Images can be uploaded to the Comfort Sync™ thermostat from the consumer portal site (www.mycomfortsync.com) under the tab "skins".

Access installer program from Home screen

To access the installer program after the unit has been placed in operation and the user home screen is displayed, press the Comfort Sync logo and hold for 5 seconds (see figure 31). The system will access the installer screens.

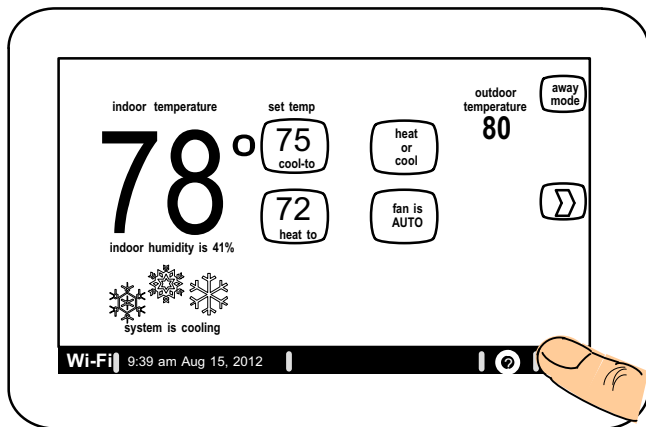

Figure 31. Enter installation setup mode from home screen

A message screen stating "Qualified Comfort Sync equipment installer warning" screen appears (Figure 32). Press **yes** to proceed (**no** returns to the home screen).

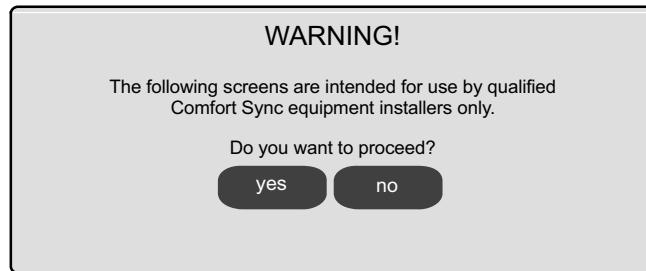

Figure 32. Qualified Comfort Sync equipment installer warning

When you press **yes**, the thermostat's processor will search for communicating devices in the system. The next display will be a summary of all alerts detected (see figure 33A).

After initial installation, if an alert is present when you are making changes to settings, no action on the alert is mandatory.

Reconfigure a system

If any component of the HVAC system has been changed, e.g. replacing an outdoor sensor, reconfiguring the system will be required. To begin reconfiguring a system (after you have accessed the program from the “Swoosh” logo [previous page]), press the **setup** button (1, figure 33A). The “Start system configuration” screen (fig. 33B) will appear. Press **start** (2, figure 33B) to proceed. The “Re-configure confirmation” screen (fig. 33C) will appear. This reminder notes that *system configuration* may affect some existing device settings and prompts to **confirm** or **cancel** the configuration process.

Press **confirm** (3, figure 33C) to continue system configuration; the screen will change to the system discovery screen. At this point, the program goes through the same setup as the initial setup process which begins on Page 4.

NOTE - “Compatible device found” screen (shown below) appears only when a device has been removed and replaced with a compatible device.

Missing	Found Compatible
Device Equipment Type No.	Device Equipment Type No.
Model No. (control model no.)	Model No. (control model no.)
Serial No. (control serial no.)	Serial No. (control serial no.)
Settings were not copied	

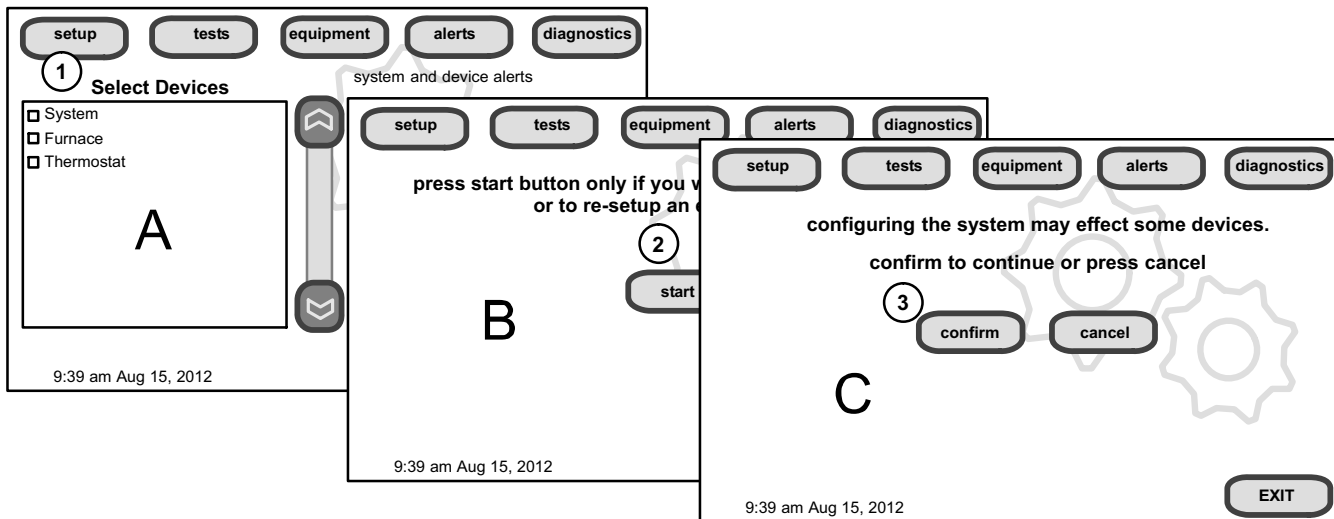

Figure 33. Re-configuration process

Stage Delay & Differential Settings (Installer settings)

1st Stage Differential—Stage 1 differential is used in all thermostats. The default is 1.0°F but can be programmed between 0.5° and 3.0°F in 0.5°F increments.

From the equipment button, use the arrows to select 1st Stage Differential. Press **edit**. Use the up/down arrows to adjust to the desired setting and press **save**.

2nd Stage Differential (where applicable)—The default is 1.0°F but can be programmed between 0.5° and 8.0°F in 0.5°F increments.

3rd Stage Differential through 6th Stage Differential (where applicable)—The default is 0.5°F but can be programmed between 0.5°F and 8.0°F in 0.5°F increments.

NOTE - Each stage's differential is based on the previous stage's differential endpoint. For example, in cooling mode, if stage 1 differential is set to 1.0°F, then the system comes on 0.5°F above setpoint and the 2nd differential starts at the 0.5°F stage 1 endpoint and extends to 2nd stage differential endpoint.

NOTE - In normal operation, the end of the cooling demand is at the setpoint -0.5°F and the end of the heating demand is at the setpoint +0.5°F.

Staged Delay Timers—default Enabled. When ON, all stage delay timers (stages 2 through 6) are enabled and will serve to bring on additional stage(s) of cooling or heating on a timed basis (default 20 minutes) in cases when the

previous stage of heating or cooling will not raise or lower the room temperature to the setpoint in a given time.

When Disabled is selected all stage delay timers are disabled. This means stages are changed based on the temperature and not their timer delays.

NOTE - The 2nd Stage Delay Timer (when Staged Delay Timers is Enabled) is used for both HEATING and COOLING. However, if the system has a variable capacity furnace, 2nd Stage Delay Timer will only be used for COOLING (not for heating, as the variable capacity algorithm ignores delay timers).

2nd thru 6th Stage Delay timer (where applicable)—If Staged Delay Timers are Enabled, the default delay is 20 minutes but can be programmed from 5 to 120 minutes in 5-minute increments. If first stage fails to advance the ambient temperature toward the setpoint by 1.0°F in the programmed delay time, then the second stage is activated.

Heat Cool Stages Locked In—default Disabled (heat/cool stages are turned off separately). If changed to Enabled, heat/cool stages are turned off together. Scroll to Heat Cool Stages Locked In; press **edit**. Use arrows to select between Disabled or Enabled. Press **save**.

Lock In 2nd stage HP by Outdoor Temp—default Off (heat pump stage 2 operates normally). Use this setting to lock in the 2nd stage compressor when the outdoor temperature is at or less than the LOCK TEMP setpoint. Scroll to Lock In 2nd stage HP by Outdoor Temp; press **edit**. Use arrows to select a temperature between 40 and 55°F. Press **save**.

Smooth Setback Recovery (SSR)

SSR is an algorithm designed to “smoothly” reach a occupied program schedule setpoint. The algorithm looks 2 hours ahead for the occupied program schedule period’s setpoint. If the occupied setpoint requires the system to turn on (present temperature below the heat setpoint or above the cool setpoint), then SSR will calculate a new setpoint. Once initiated, SSR monitors the change in room temperature and calculates a new setpoint every 30 seconds. Then SSR provides this new setpoint for the heating and cooling algorithms; the new setpoint will be displayed on the User Interface.

Rules for SSR:

1. SSR is enabled when “Smooth Setback Recovery” is set to **enabled** and the program schedule is turned on.
2. When SSR is enabled, then it will check for a new setpoint every 30 seconds.
3. The SSR Target Program Schedule setpoint is always 2 hours ahead.
4. When SSR starts, then the Current SSR setpoint will equal the current program schedule setpoint.
5. When a new program schedule period starts, then the New SSR setpoint will equal the new program schedule period’s setpoint, unless there are two or more program periods within the 2 hour window. In this case, SSR will track the highest heat setpoint or the lowest cool setpoint found in the 2 hour window.
6. SSR will NOT run during a program schedule HOLD.
7. SSR does NOT look at the current temperature.
8. If the target program heat setpoint is lower than the Current SSR heat setpoint, then the New SSR Heat Setpoint will equal the Current SSR Setpoint.
9. If the target program cool setpoint is higher than the Current SSR cool setpoint, then the New SSR Cool Setpoint will equal the Current SSR Setpoint.
10. The New SSR Setpoint will be displayed on the User Interface.
11. SSR does NOT control the equipment.
12. SSR does NOT turn off Stage Delay Timers.
13. SSR does NOT round the newly rounded setpoint, but the setpoint shown on the user interface is rounded.
14. SSR will NOT change the Temperature Dead band.
15. SSR will not adjust a setpoint to violate the Temperature Dead band.
16. SSR will not overshoot the Target Setpoint.

Heat Pump, Dual Fuel and Balance Points

IMPORTANT - The Balance Points feature requires that a sensed outdoor temperature is provided to the thermostat. This can be either a connection to Wi-Fi (for local temperature information) or a connection to an outdoor sensor (included in all communicating Comfort Sync-enabled heat pumps; optional outdoor temperature sensor X2658 for non-communicating heat pumps).

Heat Pump Balance Points

The LOW and HIGH setpoints may be controlled by the ComfortSync™ thermostat using the LOW and HIGH Balance Points feature. To enable the Balance Points feature, go to the installer section equipment button. Scroll down to the “System” screen, select **edit** and scroll down to Balance Points Controls. Use arrows to select **Enabled** and then press **save**. See the flow-chart (Page 33) for a simplified explanation of how balance points control system operation.

Low Balance Point

If the outside temperature is below the programmed low balance point (set by default at 25°F), compressor operation is not allowed. Since the heat

pump is not as effective at a lower outdoor temperatures, it may be more comfortable to use the auxiliary electric heat or the furnace (in dual fuel systems, it may be more economical) to satisfy a demand for heat. The low balance point options are from -20°F to the high balance point temperature. The setpoint can be adjusted in 1.0°F steps.

High Balance Point

If the outside temperature is above the programmed high balance point (set by default at 50°F), auxiliary electric heat operation or furnace operation (in dual fuel system) is not allowed. This ensures that the lower cost heat pump operation will satisfy the heating demand, rather than the more expensive auxiliary electric heat. The high and low balance points will not lock out both compressor heat and auxiliary heat/furnace at the same time.

Dual Fuel Applications (Communicating Systems Only)

Dual fuel applications, which include both a Heat Pump and a gas furnace, will provide multiple stages of heating. For example, a two-stage heat pump would deliver two stages of heat. The gas furnace can add two to four more stages of heat. Figure 34 flow chart illustrates Dual Fuel operation with Balance Points.

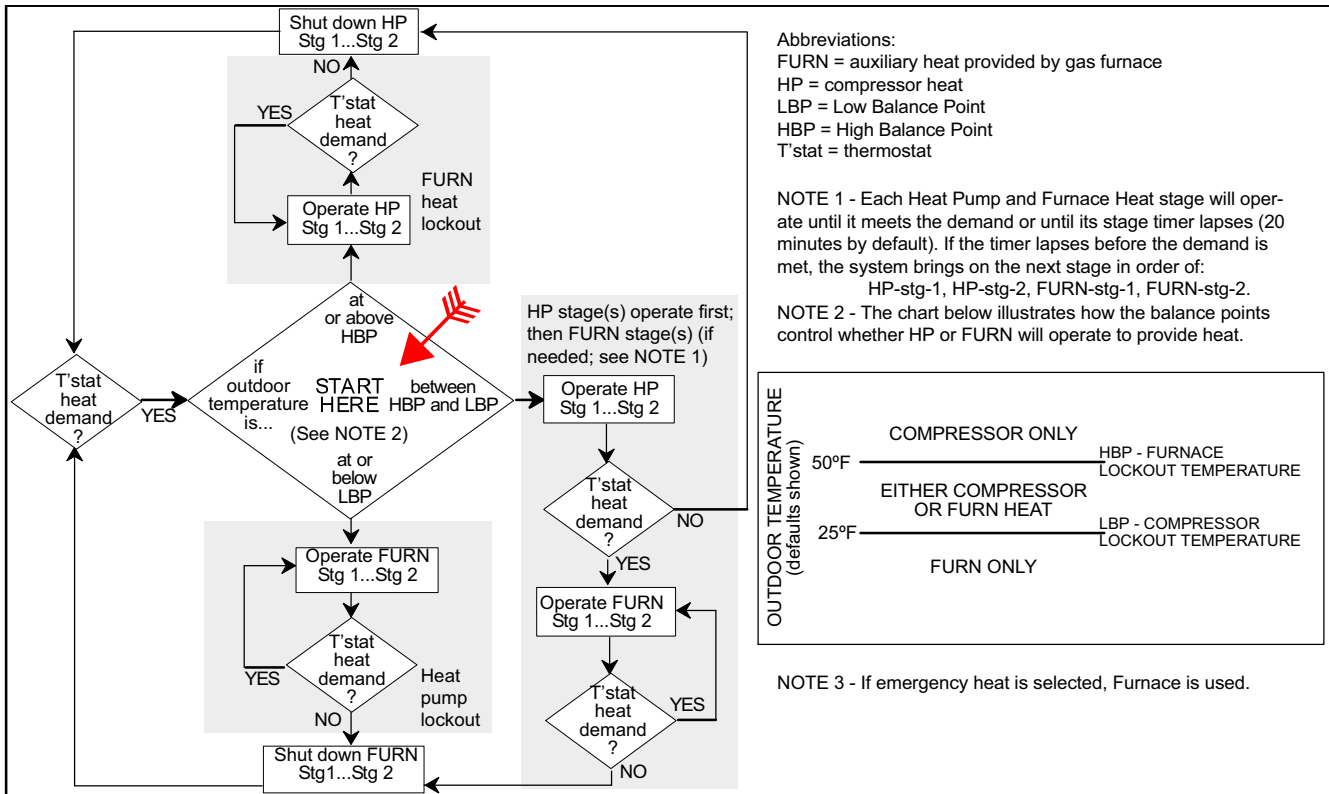

Figure 34. Dual Fuel Operation with Balance Points

Gas Heat Control Mode

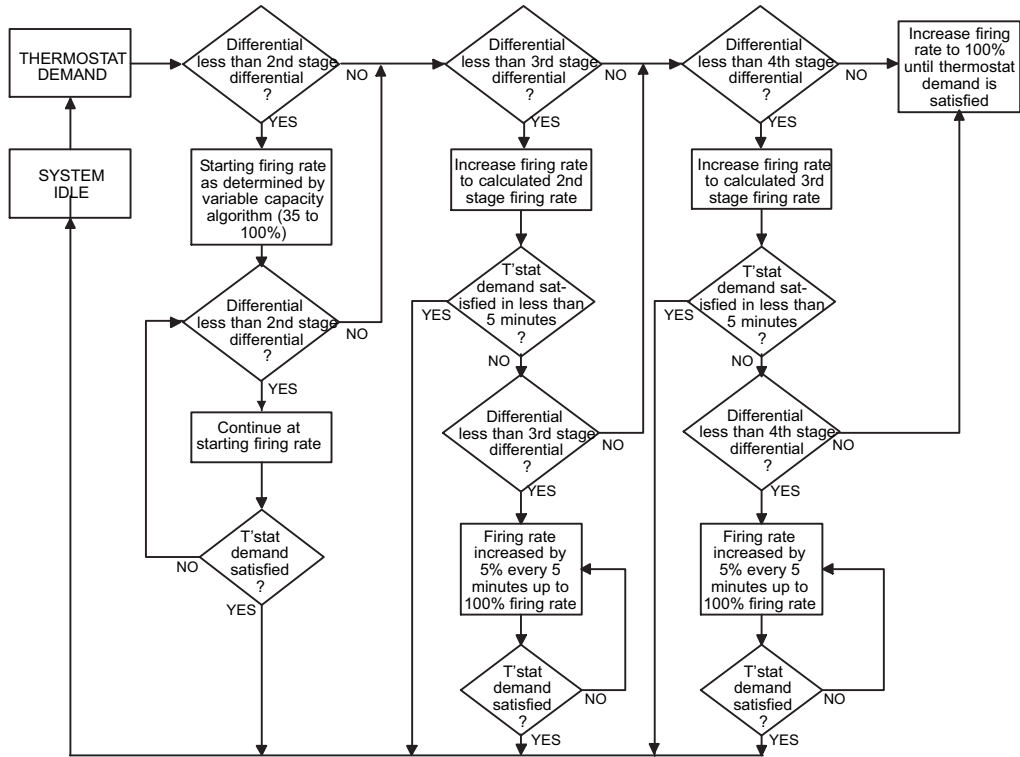

Figure 35. Variable Capacity Operation Flow Chart

Variable Capacity Control of Gas Heat Mode

The thermostat includes a feature that provides variable capacity control of the gas heat mode. The purpose of variable capacity control is to keep the room temperature at, or near, the desired setpoint with minimum system cycling. The thermostat bases its “decisions” for furnace operation control using the following inputs:

- Room temperature,
- History of cycle times (how long does it typically take to bring the room temperature to the desired setpoint),
- Target setpoint, and
- Differential temperature settings between 1st - 4th stage.

The thermostat uses this information to vary the heating capacity to efficiently satisfy the heating demand. The full range of the furnace heating capacity (low end is a percent of the 1st stage capacity; high range is 100% of full capacity) is used. When in variable capacity gas heat mode, the furnace operation includes longer run times at lower heat stages.

Table 2 details the variable capacity furnace operation.

Staged operation

Some furnaces can be configured to provide up to four stages of gas heat operation. When staged heating is chosen, the Comfort Sync thermostat allows you to choose between 1, 2, 3 and 4 stages of heat.

Single-stage heat: 1st stage provides 100% of full capacity.

Two-stage heat: 1st stage provides 70% of full capacity; 2nd stage provides 100% of full capacity.

Three-stage heat: 1st stage provides 60% of full capacity; 2nd stage provides 80% of full capacity; 3rd stage provides 100% of full capacity.

Four-stage heat: 1st stage provides 35 or 40% of full capacity; 2nd stage provides 60% of full capacity; 3rd stage provides 80% of full capacity; 4th stage provides 100% of full capacity.

A97_SMV variable capacity furnaces BTU's firing rates can be incremented by as little as 1% (40% to 100% range available) as the thermostat algorithm

may dictate. The thermostat monitors room temperature, previous heat cycle times, and target set point to determine the starting firing rate, and any required firing rate increases during the thermostat demand.

During a heat demand, the ComfortSync™ thermostat monitors the differential between set point and room temp. As this differential increases and reaches field adjustable levels (stages), the thermostat will increase firing rate accordingly to maintain room temperature and ultimately satisfy the heat demand. On the next heat cycle, the thermostat will calculate a new starting firing rate (in 1% increments) with the goal of maintaining room temperature at, or near, thermostat set point with a minimum of system cycling. The principles of operation are described in figure 35 and table 2.

Table 2. Variable Capacity Furnace Operation

T'stat Demands	Operation
None	Furnace is off
First level heat demand.	<ol style="list-style-type: none">1. Furnace BTU rate is calculated by the Comfort Sync integrating algorithm.2. Furnace firing rate will continue at current heating rate until first stage demand is satisfied or an additional thermostat demand is received.
Second level heat demand added	<ol style="list-style-type: none">1. Thermostat will immediately increase variable capacity furnace firing rate to the calculated BTU percentage representing the second stage thermostat demand.2. Furnace firing rate will increase by 5% every 5 minutes (up to 100% if second stage thermostat is not satisfied.) If thermostat second stage demand is satisfied the current firing rate will continue until all thermostat demands are satisfied.
Third level heat demand added.	<ol style="list-style-type: none">1. Thermostat will immediately increase variable capacity furnace firing rate to the calculated BTU percentage representing the third stage thermostat demand.2. Thermostat will increase the firing rate by 5% every 5 minutes (up to 100% if third stage thermostat is not satisfied.) If thermostat third stage demand is satisfied the current firing rate will continue until all thermostat demands are satisfied.
Fourth level heat demand added.	Comfort Sync thermostat will immediately set variable capacity furnace firing rate to 100% until all thermostat demands are satisfied.

Load-tracking Variable Capacity FAQs (A97_MV only)

What is Load-tracking Variable Capacity? When an A97_MV Furnace is connected to a ComfortSync™ thermostat, the thermostat takes complete charge of the variable capacity staging of the furnace. Load-tracking Variable Capacity is only available with Comfort Sync Wi-Fi thermostats.

How is Load-tracking Variable Capacity different from Variable Capacity? Load-tracking Variable Capacity will smoothly track the load (sensible temperature changes) up and down and adjust the furnace heating rate both ways. Variable capacity only tracks the load upward (rising temperature). Variable capacity uses the thermostats stage differentials but not stage timers. LVC disregards both stage differentials and stage timers.

What makes Load-tracking Variable Capacity work? With Comfort Sync Load-tracking Variable Capacity, the thermostat uses a Proportional Integral Algorithm (PIA) to control firing rates of the furnace. The algorithm in the Load-tracking Variable Capacity provides much more precise control over the furnace than the Variable Capacity algorithm.

Interesting points about the Proportional Integral Algorithm (PIA):

- The further temperature is from the current set point, the higher PIA sets the heating rate.
- The longer away from a programmed set point, the higher the heating rate.
- If needed, PIA will turn heating on and off in short cycles when there is a heat demand that is lower than the lowest the furnace can provide.
- If the heat demand is higher than the minimum the furnace can provide, the furnace will run without shutting off.
- As the room temperature rises nearer the set point, the heating rate will decrease.
- As the room temperature falls further away from the set point, the heating rate will increase.
- The stage differentials have no effect when running the PIA.
- The second stage timers have no effect when running the PIA.

Table 3. Adjustable Parameters Table (Installer)

Parameter Name:	Default	Parameter Value Setting	Increment	Installer entry
System (Go to equipment button and scroll to System) NOTE - All of the following changes are made on the stat.				
Equipment Name	—	(keyboard input screen)	—	
Filter 1 Timer Selection	Calendar Time	Calendar Time, Run Time	—	
Filter 2 Timer Selection	Calendar Time	Calendar Time, Run Time	—	
UV Bulb Timer Selection	Calendar Time	Calendar Time, Run Time	—	
Humidifier Pad Timer Selection	Calendar Time	Calendar Time, Run Time	—	
Smooth Setback Recovery	Enabled	Enabled, Disabled	—	
Auto Changeover - Temp Deadband	5°F	3 to 9°F	1°F	
Electric Heat Control Mode	Standard	Standard, Even Heat	—	
Gas Heat Control Mode: (A97_MV) (A80_2V)	Load Tracking	Load Tracking Variable Capacity, Variable Capacity, Staged	—	
	Staged	Staged only	—	
Max Heat Setpoint	90°F	40 to 90°F	1°F	
Min Cool Setpoint	60°F	60 to 99°F	1°F	
Heat Cool Stages Locked In	Disabled	Enabled, Disabled	—	
*1st Stage Differential	1.0°F	0.5 to 3°F	0.5°F	
*2nd Stage Differential	1.0°F	0.5 to 8°F	0.5°F	
*3rd Stage Differential	0.5°F	0.5 to 8°F	0.5°F	
*4th Stage Differential	0.5°F	0.5 to 8°F	0.5°F	
*5th Stage Differential	0.5°F	0.5 to 8°F	0.5°F	
*6th Stage Differential	0.5°F	0.5 to 8°F	0.5°F	
Stage Delay Timers	Enabled	Enabled, Disabled	—	
*2nd Stage Delay	20 Minutes	5 to 120 Minutes	5 Min	
*3rd Stage Delay	20 Minutes	5 to 120 Minutes	5 Min	
*4th Stage Delay	20 Minutes	5 to 120 Minutes	5 Min	
*5th Stage Delay	20 Minutes	5 to 120 Minutes	5 Min	
*6th Stage Delay	20 Minutes	5 to 120 Minutes	5 Min	

*Number of stages shown in thermostat is dependent on equipment that is installed. Electric heat will bring on 2 elements at a time if available.

table continued on next page

Table 3. Adjustable Parameters Table (Installer)

Parameter Name:	Default	Parameter Value Setting	Increment	Installer entry
Lock in 2nd stage HP by Outdoor Temp	Off	Off, 40°F (4°C), 45°F (7°C), 50°F (10°C), 55°F (13°C)	—	
Balance Point Control	Disabled	Enabled, Disabled	—	
High Balance Point	50°F	-17°F to 75°F	1°F	
Low Balance Point Control	25°F	-20°F to 72°F	1°F	
Defrost Target Discharge Temp	55°F	50°F to 60°F	1°F	
Dehumidification Control Mode	Display Only	Display Only, Basic, Precision (only available when NO dehumidifier is installed)	—	
Humidification Control Mode	Display Only	Display Only, Basic, Precision, Basic Dew Point Control, Precision Dew Point Control	—	
Autochangeover Humidification Deadband	5%	5% to 10%	1%	
Max Humidification Setpoint	45%	15% to 45%	1%	
Min Dehumidification Setpoint	40%	40% to 60%	1%	
Max Dehumidification Setpoint	40%	40% to 60%	1%	
OK/Humid Boundary	50%	45% to 60%	1%	
Outdoor Temperature Reading Calibration	0	-10°F to 10°F	1%	

OUTDOOR EQUIPMENT (Go to EQUIPMENT button and scroll to HEAT PUMP or AIR CONDITIONER.)

Equipment Name (HP & AC)	Outdoor Unit	(keyboard input screen = up to 35 characters in string)	—	
Compressor Short Cycle Delay (HP and AC)	300 Seconds	60 to 300 Seconds	60 Sec	
Compressor Shift Delay On/Off (HP only)	On	On, Off	—	
Defrost Termination Temp (HP only)	50°F	50°F to 100°F	10°F	

table continued on next page

Table 3. Adjustable Parameters Table (Installer)

Parameter Name:	Default	Parameter Value Setting	Increment	Installer entry
AIR HANDLER				
Equipment Name	Air Handler	(keyboard input screen)	—	
Electric Heating Airflow	nnnn CFM (See Note 3 at end of table)	NOTE: CFM Default and Values Settings are dependent on the tonnage of the unit	5CFM	
Low Cooling Airflow			5CFM	
High Cooling Airflow			5CFM	
Cooling Airflow Profile	1	1: No Delays, 2: ON: No delays; OFF: 45 sec delay 3: ON: 82%/7.5min; OFF: No delays 4: ON: 50%/30s,82%/7.5min; OFF:50%/30s	—	
Low Heating Airflow	nnnn CFM (See Note 3 at end of table)	NOTE: CFM Default and Values Settings are dependent on the tonnage of the unit	5CFM	
High Heating Airflow			5CFM	
Continuous Indoor Blower Airflow			10CFM	
Humidification Airflow			10CFM	
Dehumidification Airflow	70%	60 to 80% (percentage of reduction of High Cooling Airflow)	1%	
Delays:				
Heating Indoor Blower OFF	10 sec	0 to 10 Seconds	1 sec	
Heating Indoor Blower ON	0 sec	0 to 5 Seconds	1 sec	
Cooling Indoor Blower OFF	0 sec	0 to 30 Seconds	2 sec	
Cooling Indoor Blower ON	2 sec	0 to 10 Seconds	1 sec	
HP Indoor Blower OFF	45 sec	0 to 60 Seconds	5 sec	
HP Indoor Blower ON	0 sec	0 to 30 Seconds	5 sec	

Table 3. Adjustable Parameters Table (Installer)

Parameter Name	Default	Min.	Max.	Incr.	Dependency	Note	Installer entry
FURNACE							
Heating indoor blower OFF delay	DIP SW	60	180	10	None	DIP switch setting in Non-comm.	
Heating indoor blower ON delay	45 sec	15	45	5	None	45 sec fixed in Non-Comm. IFC	
Cooling indoor blower OFF delay	0 sec	0	30	2	Outdoor Unit present	Not used on Non Comm. IFC	
Cooling indoor Blower ON Delay	2 sec	0	10	1	Outdoor Unit present	2 sec fixed in Non-Comm. IFC	
Heat pump indoor blower OFF delay	45 sec	0	60	5	Heat Pump present	Not used on Non Comm. IFC	
Heat pump indoor blower ON delay	0 sec	0	30	5	Heat Pump present	Not used on Non Comm. IFC	
Gas Heat Airflow Settings							
Heating Airflow Control Type (variable capacity furnaces only)	0 – Fixed CFM	0	1	1	DATS installed	0 (Fixed CFM) 1 (Fixed DAT)	
Low Heating Airflow (CFM @ min. heat)	DIP SW	See furnace documentation (IOM or engineering handbook) for size specific information		25	Heating Airflow Control Type = 0	See furnace documentation (IOM or engineering handbook) for size specific information	
High Heating Airflow (CFM @ 100% heat)	DIP SW			25			
Low Heating Discharge Air Temperature (DAT @ min heat) (variable capacity furnaces only)	DIP SW*			5	Heating Airflow Control Type = 1		
High Heating Discharge Air Temperature (DAT @ 100% heat) (variable capacity furnaces only)	DIP SW*			5			
* - Default DAT value is rounded to the closest number on 5 deg F resolution and limited by Minimum and Maximum value.							

table continued on next page

Table 3. Adjustable Parameters Table (Installer)

Parameter Name	Default	Min.	Max.	Incr.	Dependency	Note	Installer entry
Cooling Airflow Settings							
High Cooling Airflow (CFM @ 100% cool)	OU tons 400CFM	Min CFM	Max CFM	25	Outdoor Unit present	1/2 HP blower	
		Min CFM	Max CFM	25		1 HP blower	
Low Cooling Airflow (CFM @ lowest cool stage)	(See Note 1 at end of table)	Min CFM	Max CFM	25	2+ stage Outdoor Unit present	1/2 HP blower	
		Min CFM	Max CFM	25		1 HP blower	
Airflow Profile - Cooling	DIP SW	0	3	1	Outdoor Unit present	0 A:ON:50%/30s,82% / 7.5min OFF:50%/30s 1 B:ON:82% / 7.5min; OFF: No delays 2 C:ON: No delays; OFF: 45sec delay 3 D:No delays)	
Heat Pump Airflow Settings							
High Heat Pump Airflow (CFM @ 100%)	OU tons 400CFM	Min CFM	Max CFM	25	Heat Pump present	1/2 HP blower	
		Min CFM	Max CFM	25		1 HP blower	
Low Heat Pump Airflow (CFM @ lowest stage)	(See Note 2 at end of table)	Min CFM	Max CFM	25	2+ stage Heat Pump present	1/2 HP blower	
		Min CFM	Max CFM	25		1 HP blower	

table continued on next page

Table 3. Adjustable Parameters Table (Installer)

Parameter Name	Default	Min.	Max.	Incr.	Dependency	Note	Installer entry
Other Parameters							
Equipment Name	Furnace	N/A	N/A	N/A	None	Up to 35 characters	
Continuous Indoor Blower Airflow	DIP SW (See Note 3 at end of table)	Min CFM	Max CFM	25	None	1/2 HP blower	
		Min CFM	Max CFM	25		1 HP blower	
Humidification Airflow	Same as above	Min CFM	Max CFM	25	Humidifier present	1/2 HP blower	
		Min CFM	Max CFM	25		1 HP blower	
Dehumidification Airflow Percentage	140 (=70%)	120 (=60%)	160 (=80%)	2 (=1%)	OU present and SC (Subnet Controller) algorithm support	Percent of High Cooling Airflow	
<p>Note 1: Minimum Outdoor Unit Cooling Stage as a percentage of High Cooling Airflow (value is rounded up to the closest number on 25 CFM resolution).</p> <p>Note 2: Minimum Outdoor Unit Heating Stage as a percentage of High Heat Pump Airflow (value is rounded up to the closest number on 25 CFM resolution).</p> <p>Note 3: All communicating Installer Parameters default CFM values based on DIP switch setting (non-communicating value) are calculated using the CFM conversion tables and rounded up to closest number on 25 CFM resolution.</p> <p>Note 4: Parameter dependency - Certain parameters are dependent on others and may not be shown on the display.</p> <p>Note 5: Default Values - Jumper/DIP switches impact the default value of some parameters.</p>							

Table 4. Adjustable Parameters Table (User)

Parameter Name:	Default	Parameter Value Setting	Increment	Installer entry
Time and Date *	—	(Time/date elements screen)	—	
Daylight Saving Time *	Enabled	Enabled, Disabled	—	
Fan	auto	auto, on, circulate	—	
System Name	—	(keyboard input screen)	—	
SERVICE INFORMATION				
Dealer Name	your dealer	(keyboard input screen)	—	
Dealer Address	—	(keyboard input screen)	—	
Dealer Phone	1-800-448-5872	(keyboard input screen)	—	
Dealer Email	—	(keyboard input screen)	—	
Dealer Website	—	(keyboard input screen)	—	
Language Displayed	English	English, French, Spanish	—	
Temperature Display Scale **	(F)	(F) Fahrenheit, (C) Celsius	—	
Clock Format	12H	12 Hour, 24 Hour	—	
Screen Lock-out	Unlocked	Unlocked, Partially Locked, Fully Locked	—	
Backlight Setting	Always On	Power Save, Always On	—	
Backlight Intensity	100%	20 to 100%	20%	
Outdoor Temp Display	is OFF	is OFF, is ON	—	
Indoor Humidity Display	is OFF	is OFF, is ON	—	
Power Save	is ON	is OFF, is ON	—	
Background theme	cobalt	cobalt, cotton, carbon	—	
* Entered during initial installer setup (during initial discovery); should be edited from user preferences.				
** When Celsius mode is chosen, Celsius is only changed on home screen; all calculations and other setting are in Fahrenheit.				

table continued on next page

Table 4. Adjustable Parameters Table (User)

Parameter Name:	Default	Parameter Value Setting	Increment	Installer entry
Filter 1 Timer	Disabled	Disabled, 3 Months, 6 Months, 12 Months, 24 Months, Custom Time	—	
Filter 1 Timer	Disabled	Disabled, 3 Months, 6 Months, 12 Months, 24 Months, Custom Time	—	
Humidifier Pad Timer	Disabled	Disabled, 3 Months, 6 Months, 12 Months, 24 Months, Custom Time	—	
UV Bulb Timer	Disabled	Disabled, 3 Months, 6 Months, 12 Months, 24 Months, Custom Time	—	
Maintenance Timer	Disabled	Disabled, 3 Months, 6 Months, 12 Months, 24 Months, Custom Time	—	
THERMOSTAT (Go to equipment button and scroll to Thermostat.)				
NOTE - These settings apply to the thermostat's internal sensors.				
Equipment Name	—	(keyboard input screen)	—	
Temp Reading Calibration	0°F	-5°F to 5°F	1°F	
Humidity Reading Calibration	0%	-10 to 10%	1%RH	

Table 5. Alert Codes and Troubleshooting

Critical alerts are displayed on Home (user) screen, in the Homeowner alert button, and in the Installer alert button. Minor and Moderate alerts are found only in the Installer alert button.

Alert Code	Priority	Alert Text	Steps to clear
10	Critical	(Stat) The thermostat has found an unknown device on the system.	An unknown device is seen on the subnet in or outside of configuration mode. Clear by reconfiguring the system. Press the setup tab, press start, and press confirm. If problem persists, then check all DEVICE connections to make sure they are Comfort Sync-compatible.
11	Critical	(Stat) The thermostat cannot find a previously installed unit.	Check all connections and cycle system power. If problem persists, clear by reconfiguring the system. Press the setup tab, press start, and press confirm. If problem persists, then check all DEVICE connections to make sure they are Comfort Sync-compatible.
12	Critical	(Stat) The thermostat cannot find an Comfort Sync-enabled indoor unit.	Thermostat did not find an Indoor Unit. Make sure there is an Comfort Sync indoor unit on the system. Check R, i+, i- and C connections, ohm wires and cycle power. Replace indoor unit control board if there is no response.
14	Critical	(Stat) The thermostat found more than one thermostat, more than one indoor unit, or more than one outdoor unit on the system.	Check wiring and remove duplicate equipment. Reconfigure system.
18	Minor	(Stat) The outside temperature is below the level where the heat pump is programmed to heat the home. The system will not use the heat pump to warm your home.	Notification only - Outdoor Temp is below the Low Balance Point. Heat Pump will not be used to service a heating demand.
19	Minor	(Stat) The outside temperature is higher than the level where the furnace or electric heat is programmed to work. The system will only use the heat pump to warm your home.	Notification only - Outdoor Temp is above the High Balance Point. Indoor Unit (furnace or air-handler) will not be used to service a heating demand.
29	Critical	(Stat) The thermostat is reading an indoor temperature that is higher than 99°F. The thermostat will not allow any heating operation to begin until it senses a temperature lower than 99°F.	Indoor temperature rose above 99°F during a heating or cooling demand. Heating operation is not allowed. Check to ensure that Heating Equipment is not stuck ON (reversing valve, etc.). Check the accuracy of the thermostat temperature sensor. Select cooling system mode to cool the indoor space.
30	Moderate	(Stat) The thermostat is reading an indoor temperature that is lower than 40°F. The thermostat will not allow any cooling operation to begin until it senses a temperature higher than 40°F.	Indoor Temp fell below 40°F. Cooling operation is not allowed. Check to ensure that cooling equipment is not stuck ON. Check accuracy of the thermostat temperature sensor. Select heating system mode to heat the indoor space to above 40°F.
31	Critical	(Stat) The thermostat has lost communication with the (furnace, air-handler or outdoor unit) for more than 3 minutes.	<i>[Indicated unit]</i> has not communicated with thermostat for more than 3 minutes. Check connections. Ohm wires. If fault persists, then cycle power. Fault clears after communication is restored.
32	Moderate	(Stat) The (furnace, air-handler or outdoor unit) is resetting itself.	<i>[Indicated unit]</i> is resetting itself. This event may occur during a power outage or power fluctuation in the system. If persistent or if it coincides with the system operation then proceed with the following steps. Check the power connections, check the amp draw at the transformer (the transformer maybe overloaded) and check 24VAC voltage at the DEVICE. The alarm is only cleared by pressing the clear button on the Installer Alerts Tab. If the fault persists after checking the connections, replace the unit's control board.

table continued on next page

Table 5. Alert Codes and Troubleshooting

Critical alerts are displayed on Home (user) screen, in the Homeowner alert button, and in the Installer alert button. Minor and Moderate alerts are found only in the Installer alert button.

Alert Code	Priority	Alert Text	Steps to clear
34	Critical	(Stat) The thermostat does not know the capacity (tonnage) of the <i>(furnace, air-handler or outdoor unit)</i> . Please program the correct capacity of the <i>(furnace, air-handler or outdoor unit)</i> .	<i>[Indicated unit]</i> is missing the programmed unit capacity. Go to <i>[Indicated unit]</i> and program the unit capacity manually. See the unit IOM for programming instructions. Remove power to thermostat before programming the unit control board. Once programming is complete, reconnect thermostat wires and reconfigure system.
36	Critical	(Stat) The system has been heating for at least 15 minutes, without a demand for heating.	Run the system in diagnostic mode and verify that it matches actual equipment operation. Check for other alarms/codes that may be preventing the system from operating as expected. Step 1: Check all heating equipment to determine cause of heating demand. Step 2: Recycle power. System will clear code when it detects condition has cleared.
37	Critical	(Stat) The system has been cooling for at least 15 minutes, without a demand for cooling.	Run the system in diagnostic mode and verify that it matches actual equipment operation. Check for other alarms/codes that may be preventing the system from operating as expected. Step 1: Check all cooling equipment to determine cause of cooling demand. Step 2: Recycle power. System will clear code when it detects condition has cleared.
38	Critical	(Stat) The system has not been able to turn on the heating for more than 45 minutes. The system will go offline for 60 minutes and try again.	Run the system in diagnostic mode and verify that it matches actual equipment operation. Check for other alarms/codes that may be preventing the system from operating as expected. Step 1: Check all heating equipment to determine cause. Step 2: Recycle power. System will clear code when it detects condition has cleared.
39	Critical	(Stat) The system has not been able to turn on the cooling for more than 45 minutes. The system will go offline for 60 minutes and try again.	Run the system in diagnostic mode and verify that it matches actual equipment operation. Check for other alarms/codes that may be preventing the system from operating as expected. Step 1: Check all cooling equipment to determine cause. Step 2: Recycle power. System will clear code when it detects condition has cleared.
105	Critical	(Stat / Furnace / Air Handler / Outdoor Unit) The <i>(stat, furnace, air-handler or outdoor unit)</i> has lost communication with the rest of the system.	Equipment is unable to communicate. This may indicate the existence of other alarms/codes. In most cases errors are related to electrical noise. Make sure high voltage power is separated from RSBus. Check for mis-wired and/or loose connections between the stat, indoor unit and outdoor unit. Check for a high voltage source of noise close to the system. Generally, this is a self-recoverable error.
110	Critical	(Furnace) The line voltage is too low.	This alarm/code may appear during a brownout. Line voltage is below its designed operating value. Check and correct the power line voltage.
111	Critical	(Furnace) The line power voltage wiring is reversed.	The unit is reporting that its power line and neutral are reversed. Turn off the power to the system and correct the line power voltage wiring. System resumes normal operation 5 seconds after fault recovered.
112	Critical	(Furnace) The reporting device cannot find earth ground. The thermostat will shut down the system.	Provide proper earth ground to the equipment. System resumes normal operation 5 seconds after fault recovered.

table continued on next page

Table 5. Alert Codes and Troubleshooting

Critical alerts are displayed on Home (user) screen, in the Homeowner alert button, and in the Installer alert button. Minor and Moderate alerts are found only in the Installer alert button.

Alert Code	Priority	Alert Text	Steps to clear
113	Critical	(Furnace) The line voltage is too high.	Line voltage high (voltage higher than nameplate rating). Provide power voltage within proper range. System resumes normal operation 5 seconds after fault recovered.
114	Critical	(Furnace / Air Handler) There is a frequency/ distortion problem with the power to the (<i>furnace or air-handler</i>).	This alarm/code may indicate transformer overloading. Check the voltage and line power frequency. Check the generator operating frequency, if the system is running on back-up power. Correct voltage and frequency problems. System resumes normal operation 5 seconds after fault recovered.
115	Critical	(Furnace / Air Handler) The 24VAC to the (<i>furnace or air-handler control board</i>) is lower than the required range of 18 to 30VAC.	24-Volt Power Low (Range is 18 to 30 volts). Check and correct voltage. Check for additional power-robbing equipment connected to system. This alarm/code may require the installation of an additional or larger VA transformer.
117	Minor	(Furnace) The reporting unit has poor earth grounding.	Provide proper grounding for the unit. Check for proper earth ground to the system. The alarm/code will clear 30 seconds after it is corrected.
120	Moderate	(Stat / Furnace / Air Handler / Outdoor Unit) There is a delay in the (<i>stat, furnace, air-handler or outdoor unit</i>) responding to the system.	Typically, this alarm/code does not cause any issues and will clear on its own. The alarm/code is usually caused by a delay in the outdoor unit responding to the thermostat. Check all wiring connections. Cleared after unresponsive device responds to any inquiry.
124	Critical	(Stat / Furnace / Air Handler / Outdoor Unit) The thermostat has lost communication with the (<i>furnace, air-handler or outdoor unit</i>) for more than 3 minutes.	Equipment lost communication with the thermostat. Check the wiring connections, ohm wires and cycle power. The alarm stops all associated HVAC operations and waits for a heartbeat message from the unit that's not communicating. The alarm/fault clears after communication is re-established.
125	Critical	(Stat / Furnace / Outdoor Unit) There is a hardware problem on either the (<i>stat, furnace control board, air-handler control board or outdoor unit control board</i>).	There is a control hardware problem. Replace the control if the problem prevents operation and is persistent. The alarm/fault is cleared 300 seconds after the fault recovers.
126	Critical	(Furnace / Outdoor Unit) There is an internal communication problem with the (<i>furnace control board, air-handler control board or outdoor unit control board</i>).	There is an internal hardware problem on the control. Typically the control will re-set itself. Replace the control if the problem prevents operation and is persistent. The alarm/fault is cleared 300 seconds after the fault recovers.
130	Moderate	(Air Handler) An air-handler configuration jumper is missing.	Configuration jumper(s) missing on control (applicable in non-communicating applications only). Replace the jumper or put wire between terminals on control. Cleared after jumper is connected.
131	Critical	(Stat / Furnace / Air Handler / Outdoor Unit) The (<i>stat, furnace, air-handler or outdoor unit</i>) control parameters are corrupted.	Reconfigure the system. Replace the control if heating or cooling is not available.
132	Critical	(Air Handler) The air handler control software is corrupted.	Recycle power. If failure re-occurs, replace the control. System reset is required to recover.

table continued on next page

Table 5. Alert Codes and Troubleshooting

Critical alerts are displayed on Home (user) screen, in the Homeowner alert button, and in the Installer alert button. Minor and Moderate alerts are found only in the Installer alert button.

Alert Code	Priority	Alert Text	Steps to clear
180	Critical	(Furnace / Air Handler / Outdoor Unit) The thermostat has found a problem with the (furnace, air-handler or outdoor unit) outdoor sensor.	In normal operation after control recognizes sensors, the alarm will be sent if valid temperature reading is lost. Compare outdoor sensor resistance to temperature/resistance charts in unit installation instructions. Replace sensor pack if necessary. At the beginning of (any) configuration, furnace or air-handler control will detect the presence of the sensor(s). If detected (reading in range), appropriate feature will be set as 'installed' and shown in the 'About' screen. The alarm/fault will clear upon configuration, or sensing normal values.
200	Critical	(Furnace) The furnace rollout limit switch is open.	Correct the cause of rollout trip. Reset rollout switch. Reset power to clear. Test the furnace operation. The alarm/fault clears after the furnace rollout switch is closed.
201	Critical	(Furnace / Air Handler) The system has lost communication with the (furnace or air-handler) indoor blower motor.	Lost communication with indoor blower motor. Possible causes include: power outage, brown-out, motor not powered, loose wiring, condensation on air handler control without cover on breaker. Problem may be on control or motor side. Cleared after communication is restored.
202	Critical	(Furnace / Air Handler) The unit size code for the (furnace or air-handler) and the size of blower motor do not match.	Incorrect appliance unit size code selected. Check for proper configuring under Unit Size Codes for Furnace/Air Handler on configuration guide or in installation instructions. The alarm/fault clears after the correct match is detected following a reset. Remove the thermostat from the system while applying power and reprogramming.
203	Critical	(Furnace / Air Handler) The unit size code for the (furnace or air-handler) has not been selected.	No appliance unit size code selected. Check for proper configuring under: Unit Size Codes for Furnace/Air Handler on configuration guide or in installation instructions. Critical Alert. The alarm/fault clears after the correct match is detected following a reset. Remove the thermostat from the system while applying power and reprogramming.
204	Critical	(Furnace) There is a problem with the furnace gas valve.	Check gas valve operation and wiring. The alarm/fault clears after the issue is corrected.
205	Critical	(Furnace) The furnace gas valve relay contact is closed.	Check wiring on control and gas valve. The alarm/fault clears after the issue is corrected.
206	Critical	(Furnace) The furnace gas valve 2nd stage relay is faulty.	Furnace will operate on 1st stage for the remainder of the heating demand. The alarm/fault will clear after the issue is corrected. If unable to operate 2nd stage, replace control.
207	Critical	(Furnace) The furnace hot surface igniter is open.	Measure the resistance of hot surface igniter. Replace the it if it is not within the specified range found in IOM. The alarm/fault clears after the issue is corrected.
223	Critical	(Furnace) The furnace low pressure switch is open.	Check pressure (inches w.c.) of low pressure switch closing during a heat call. Measure operating pressure (inches w.c.). Inspect vent and combustion air inducer for correct operation and restriction. The alarm/fault clears after the issue is corrected.
224	Critical	(Furnace) The furnace low pressure switch is stuck closed.	Check operation of low pressure switch to see if it is stuck closed for longer than 150 seconds during a heat call . Measure operating pressure (inches w.c.). Inspect vent and combustion air inducer for correct operation and restriction. The alarm/fault clears after the issue is corrected.
225	Critical	(Furnace) The furnace high pressure switch is failing to close.	Check pressure (inches w.c.) of high pressure switch closing during a heat call. Measure operating pressure (inches w.c.). Inspect vent and combustion air inducer for correct operation and restriction. The alarm/fault clears after the issue is corrected.

table continued on next page

Table 5. Alert Codes and Troubleshooting

Critical alerts are displayed on Home (user) screen, in the Homeowner alert button, and in the Installer alert button. Minor and Moderate alerts are found only in the Installer alert button.

Alert Code	Priority	Alert Text	Steps to clear
226	Critical	(Furnace) The furnace high pressure switch is stuck closed.	Check operation of high pressure switch closing during a heat call. Measure operating pressure (inches w.c.). Inspect vent and combustion air inducer for correct operation and restriction. The alarm/fault clears after the issue is corrected.
227	Moderate	(Furnace) The furnace low pressure switch is open in run mode.	Check pressure (inches w.c.) of low pressure switch closing during a heat call. Measure operating pressure (inches w.c.). Inspect vent and combustion air inducer for correct operation and restriction. The alarm/fault clears after the issue is corrected.
228	Moderate	(Furnace) The furnace control is not able to calibrate the pressure switch.	Unable to perform pressure switch calibration. Check vent system and pressure switch wiring connections. Check the drain trap for blockage. The alarm/fault clears after a successful calibration.
229	Minor	(Furnace) The furnace control has switched to high fire ignition because the low fire pressure switch did not close in the allowed time.	IFC switched to high fire ignition because low fire pressure switch did not close in allowed time. No action is needed.
240	Moderate	(Furnace) The furnace flame current is low.	Check micro-amperes of the flame sensor using thermostat diagnostics. Clean or replace the flame sensor. Measure voltage of neutral to ground to ensure good unit ground. The alarm clears after a proper micro-amp reading has been sensed.
241	Critical	(Furnace) The furnace flame is going out while the furnace is heating.	Shut off gas. Check for a gas valve leak. Replace the gas valve if needed. The alarm/fault will clear when a heat call ends successfully.
250	Moderate	(Furnace) The furnace primary limit switch is open.	Check for proper firing rate on furnace. Ensure there is no blockage in the furnace and the ductwork. Check for proper air flow. If limit switch is not closed within 3 minutes, the unit will go into 1-hour Watchguard mode. The alarm/fault will clear when a heat call ends successfully.
252	Moderate	(Furnace) The furnace discharge air-temperature is high.	Check temperature rise, air flow and input rate. Check for dirty filters. The alarm/fault will clear when a heat call ends successfully.
270	Critical	(Furnace) The furnace is in Watchguard mode. The furnace igniter cannot turn on the flame.	Check for proper gas flow. Ensure that igniter is lighting burner. Check flame sensor current. Check for dirty filters. The alarm/fault will clear on successful ignition.
271	Critical	(Furnace) The furnace is in Watchguard mode. The furnace low pressure switch is open.	Check pressure (inches w.c.) of low pressure switch closing during a heat call. Measure operating pressure (inches w.c.). Inspect vent and combustion air inducer for correct operation and restriction. The alarm/fault will clear on successful ignition.
272	Critical	(Furnace) The furnace is in Watchguard mode. The furnace low pressure switch is open during run mode.	Check operation of low pressure switch to see if it is stuck open during a heat call. Measure operating pressure (inches w.c.). Inspect vent and combustion air inducer for correct operation and restriction. The alarm/fault will clear when a heat call ends successfully.
273	Critical	(Furnace) The furnace is in Watchguard mode. The furnace flame is going off during a heating cycle.	Check micro-amperes of flame sensor using thermostat diagnostics. Clean or replace sensor. Measure voltage of neutral to ground to ensure good unit ground. The alarm/fault will clear when a heat call ends successfully.
274	Critical	(Furnace) The furnace limit switch has been open for more than 3 minutes.	The system will go into Watchguard mode. Check firing rate and air flow. Check for blockage. The alarm/fault will clear when a heat call ends successfully.

table continued on next page

Table 5. Alert Codes and Troubleshooting

Critical alerts are displayed on Home (user) screen, in the Homeowner alert button, and in the Installer alert button. Minor and Moderate alerts are found only in the Installer alert button.

Alert Code	Priority	Alert Text	Steps to clear
275	Critical	(Furnace) The furnace flame is out of sequence.	The system will go into Watchguard mode. Shut off gas. Check for gas valve leak. The alarm/fault will clear on next successful ignition.
276	Critical	(Furnace) The furnace is not able to calibrate or the high pressure switch opened or failed to close in run mode.	The system will go into Watchguard mode. Check vent system and pressure switch wiring connections. The fault/alarm will clear when the furnace calibrates itself successfully.
290	Critical	(Furnace) There is a problem with the furnace ignition circuit.	The system will go into Watchguard mode. Measure resistance of hot surface igniter. Replace the hot surface igniter if it is not within specifications. The alarm/fault will clear on next successful ignition.
291	Critical	(Furnace) The heating airflow is below the minimum required level.	The system will go into Watchguard mode. Check for dirty filters and other air flow restrictions. Check blower performance. The alarm/fault will clear when a heat call ends successfully.
292	Critical	(Furnace / Air Handler) The (furnace or air-handler) indoor blower motor will not start.	The system will go into Watchguard mode. Indoor blower motor unable to start. This could be due to seized bearing, stuck wheel, obstruction etc. Replace motor or wheel if assembly does not operate or meet performance standards. The alarm/fault clears after the indoor blower motor starts successfully.
294	Critical	(Furnace) There is over current in the furnace inducer motor.	The system will go into Watchguard mode. Check combustion blower bearings, wiring and amps. Replace if does not operate or does not meet performance standards. The alarm/fault clears after inducer current is sensed to be in-range after the ignition following the Watchguard mode or reset.
295	Minor	(Furnace) The indoor blower motor is over heating.	Indoor blower motor over temperature (motor tripped on internal protector). Check motor bearings and amps. Replace if necessary. The alarm/fault clears after blower demand is satisfied.
310	Critical	(Furnace / Air Handler) There is a problem with (furnace or air-handler) discharge air sensor.	Compare outdoor sensor resistance to temperature/resistance charts in installation instructions. Replace sensor if necessary. The alarm/fault is cleared 30 seconds after fault is detected as recovered.
311	Minor	(Furnace) The heat firing rate has been reduced to match available airflow (cutback mode).	Warning Only. Furnace blower in cutback mode due to restricted airflow. Reduce firing rate every 60 seconds to match available CFM. Check filter and duct system. To clear, replace filter if needed or repair/add duct. 2-stage controls will reduce firing rate to 1st stage. The alarm/fault clears when a heat call finishes successfully.
312	Minor	(Furnace / Air Handler) The blower cannot provide the requested CFM due to high static.	Warning Only. Restricted airflow - Indoor blower is running at a reduced CFM (Cutback Mode - The variable speed motor has pre-set speed and torque limiters to protect the motor from damage caused by operating outside of design parameters (0 to 0.8" e.g., total external static pressure). Check filter and duct system. To clear, replace filter if needed or repair/add duct. The alarm/fault is cleared after the current service demand is satisfied.
313	Minor	(Furnace / Air Handler) The indoor and outdoor unit capacities do not match.	Check for proper configuring in installation instructions. Alarm is just a warning. The system will operate, but might not meet efficiency and capacity parameters. The alarm will clear after commissioning is complete.
344	Critical	(Furnace) Relay Y1 Failure	Y1 relay failed; operation stopped. Alarm clears 300 seconds after Y1 input sensed OFF.

table continued on next page

Table 5. Alert Codes and Troubleshooting

Critical alerts are displayed on Home (user) screen, in the Homeowner alert button, and in the Installer alert button. Minor and Moderate alerts are found only in the Installer alert button.

Alert Code	Priority	Alert Text	Steps to clear
345	Critical	(Air Handler) The "O" relay on the air-handler has failed. Either the pilot relay contacts did not close or the relay coil did not energize.	O relay / Stage 1 failed. Pilot relay contacts did not close or the relay coil did not energize. Replace control. Cleared after the fault recovered following reset.
346	Critical	(Air Handler) The heat pump jumper was not removed on the air-handler control board.	Configuration link(s) not removed on control. Cut O-R. Applicable with non communicating outdoor unit with communicating indoor system.
347	Critical	(Furnace / Air Handler) The "Y1" relay on the (furnace or air-handler) has failed. Either the pilot relay contacts did not close or the relay coil did not energize.	Operation stopped. Y1 relay / Stage 1 failed. (Pilot relay contacts did not close or the relay coil did not energize; no input back to IFC chip). Critical Alert. Cleared after reset and Y1 input sensed.
348	Critical	(Furnace / Air Handler) The "Y2" relay on the (furnace or air-handler) has failed. Either the pilot relay contacts did not close or the relay coil did not energize.	Y2 relay / Stage 2 failed. (Pilot relay contacts did not close or the relay coil did not energize; no input back to IFC chip). Critical Alert. Cleared after reset and Y1 input sensed.
349	Critical	(Furnace) The "O" to "R" jumper on the furnace needs to be restored.	Configuration link R to O needs to be restored. Replace link or hard-wire. Applicable in non communicating mode. Critical Alert.
350	Critical	(Air Handler) The air-handler's electric heat is not configured.	Heat call with no configured or mis-configured electric heat. Check for proper configuring under Configuring Electric Heat Stages in the air handler installation instructions. Cleared after electrical heat detection is successful.
351	Critical	(Air Handler) There is a problem with the air-handler's 1st stage electric heat. Either the pilot relay contacts did not close, or the relay coil in the electric heat section did not energize.	Heat section / Stage 1 failed. (Pilot relay contacts did not close, or the relay coil in the electric heat section did not energize.) Air handler will operate on 1st stage for reminder of the heat call. Will clear after fault recovered.
352	Critical	(Air Handler) There is a problem with the air-handler's 2nd stage electric heat. Either the pilot relay contacts did not close, or the relay coil in the electric heat section did not energize. The air-handler will operate on 1st stage electric heat until the issue is resolved.	Heat section / Stage 2 failed (Same as Code 351).
353	Critical	(Air Handler) There is a problem with the air-handler's 3rd stage electric heat. Either the pilot relay contacts did not close, or the relay coil in the electric heat section did not energize. The air-handler will operate on 1st stage electric heat until the issue is resolved.	Heat section / Stage 3 failed (Same as Code 351).

table continued on next page

Table 5. Alert Codes and Troubleshooting

Critical alerts are displayed on Home (user) screen, in the Homeowner alert button, and in the Installer alert button. Minor and Moderate alerts are found only in the Installer alert button.

Alert Code	Priority	Alert Text	Steps to clear
354	Critical	(Air Handler) There is a problem with the air-handler's 4th stage electric heat. Either the pilot relay contacts did not close, or the relay coil in the electric heat section did not energize. The air-handler will operate on 1st stage electric heat until the issue is resolved.	Heat section / Stage 4 failed (Same as Code 351).
355	Critical	(Air Handler) There is a problem with the air-handler's 5th stage electric heat. Either the pilot relay contacts did not close, or the relay coil in the electric heat section did not energize. The air-handler will operate on 1st stage electric heat until the issue is resolved.	Heat section / Stage 5 failed (Same as Code 351).
370	Critical	(Furnace) The furnace control board has not received 24VAC power for 2 minutes or more.	Control sees the loss of 24VAC for 2 minutes. Terminate all services and wait for interlock switch to close. The alarm will clear when 24VAC is continuously sensed on DS terminal for a minimum of 10 seconds or on a power reset. If 2 stage with float switch, the IFC control R-DS is open.
400	Critical	(Outdoor Unit) The compressor internal overload has tripped.	Thermostat demand Y1 is present; but, compressor is not running. Check power to unit. Clears the error after current is sensed in both RUN and START sensors for at least 2 seconds, or after service is removed, or after power reset.
401	Moderate	(Outdoor Unit) Either the compressor ran for more than 18 hours continuously trying to cool the home or the refrigerant pressure in the system is low.	Compressor ran more than 18 hours to satisfy a single thermostat demand. Will not lockout system. If 2 stage, units with blinking LED light controls, unit will run in low speed; units with 7-segment display will display code, but continue to run in high speed. If a Heat Pump, and if outdoor temp is less than 65 degrees, code is ignored. Clears the error after 30 consecutive normal run cycles or power reset. Also monitors low pressure switch trips.
402	Critical	(Outdoor Unit) Either the discharge or suction pressure level is out-of-limits, or the is compressor overloaded.	Discharge or suction pressure out-of-limits, or compressor overloaded. Clears the error after 4 consecutive normal compressor run cycles.
403	Moderate	(Outdoor Unit) The compressor ran for less than 3 minutes to satisfy a thermostat demand.	Compressor runs less than 3 minutes to satisfy a thermostat demand. Clears the error after 4 consecutive normal run cycles or power reset.
404	Critical	(Outdoor Unit) The compressor rotor is locked up. This could be due to a short circuiting of the run capacitor, seizing of the bearings or excessive liquid refrigerant etc.	Compressor rotor locked up due to run capacitor short, bearings are seized, excessive liquid refrigerant, etc. (NOTE: May need to install hard start kit). Clears the error after 4 consecutive normal run cycles or after power reset.
405	Critical	(Outdoor Unit) The compressor circuit is open. This could be due to a power disconnection, open fuse etc.	Compressor circuit open (due to power disconnection, open fuse, etc.) Clears the error after 1 normal compressor run cycle.
406	Critical	(Outdoor Unit) The required amount of current is not passing through the start current transformer.	Required amount of current is not passing through Start current transformer. Clears the error after current is sensed in START sensor, or after power reset.

table continued on next page

Table 5. Alert Codes and Troubleshooting

Critical alerts are displayed on Home (user) screen, in the Homeowner alert button, and in the Installer alert button. Minor and Moderate alerts are found only in the Installer alert button.

Alert Code	Priority	Alert Text	Steps to clear
407	Critical	(Outdoor Unit) The required amount of current is not passing through run current transformer.	Required amount of current is not passing through Run current transformer. Clears the error after current is sensed in RUN sensor, or 1 normal compressor run cycle, or after power reset
408	Critical	(Outdoor Unit) The compressor is running continuously.	Compressor runs continuously. Clears the error after 1 normal compressor run cycle or after power reset.
409	Moderate	(Furnace / Air Handler / Outdoor Unit) The secondary voltage for the (furnace, air-handler or outdoor unit) has fallen below 18VAC. If this continues for 10 minutes, the thermostat will turn off the (furnace, air-handler or outdoor unit).	Secondary voltage is below 18VAC. After 10 minutes, operation is discontinued. Clears the code after voltage is higher than 20 VAC for 2 seconds or after power reset.
410	Moderate	(Outdoor Unit) The outdoor unit pressure is below the required limit.	Unit pressures are below the lower limit. Pressure switch opens at 40 psig (system shuts down) and closes at 90 psig (system restarts).
411	Critical	(Outdoor Unit) The low pressure switch has opened 5 times during one cooling cycle. As a result, the thermostat has shutdown the outdoor unit.	Open low pressure switch error count reached 5 strikes. Check system charge using approach and sub cooling temperatures. Reset by putting outdoor unit control in test mode or resetting low voltage power.
412	Moderate	(Outdoor Unit) The outdoor unit pressure is above the required limit. The system will shut down.	Unit pressure is above the upper limit. Pressure switch opens at 590 psig (system shuts down) and closes at 418 psig (system restarts).
413	Critical	(Outdoor Unit) The high pressure switch has opened 5 times during one cooling cycle. As a result, the thermostat has shutdown the outdoor unit.	Open high pressure switch error count reached 5 strikes. Check system charge using approach and sub cooling temperatures. Check outdoor fan operation. Check for dirt or debris blocking air flow to outdoor unit. Reset by putting outdoor unit control in test mode or resetting low voltage power.
414	Critical	(Outdoor Unit) The discharge line temperature is higher than the recommended upper limit of 279°F.	Discharge line temperature is > 279°F. Make sure coil is clean and airflow unobstructed in and out of condenser. Check system operating pressures and compare to unit charging charts in installation manual. Clears after discharge temperature is < 225°F.
415	Critical	(Outdoor Unit) The discharge line temperature has been consistently higher than the recommended upper limit of 279°F.	Discharge line high temperature error count reached 5 strikes. Make sure coil is clean and airflow unobstructed in and out of condenser. Check system charge using approach and sub cooling temperatures. Reset by putting outdoor board in test mode or resetting low voltage power.
416	Critical	(Outdoor Unit) The outdoor coil sensor is either open, short-circuited or the temperature is out of sensor range. As a result the outdoor unit control will not perform any defrost tempering.	Sensor being detected open or shorted, or temperature is out of sensor range. Outdoor unit control will not perform demand or time/temperature defrost operation. (System will still heat or cool.) Clears when outdoor unit control detects proper sensor readings.
417	Critical	(Outdoor Unit) The outdoor unit sensor is either open, short-circuited or the temperature is out of sensor range. As a result the outdoor unit control will not perform any defrost tempering.	Outdoor unit control detects open or shorted sensor, or temperature that is out of sensor range. Critical Alert after 10 minutes. Reset by replacing sensor. This fault is detected by allowing the unit to run for 90 seconds before checking sensor resistance. If the sensor resistance is not within range after 90 seconds, the board will count one fault. After 5 faults, the board will lock out. Check for proper sensor reading and attachment to line. Replace if out-of-specifications.

table continued on next page

Table 5. Alert Codes and Troubleshooting

Critical alerts are displayed on Home (user) screen, in the Homeowner alert button, and in the Installer alert button. Minor and Moderate alerts are found only in the Installer alert button.

Alert Code	Priority	Alert Text	Steps to clear
418	Moderate	(Outdoor Unit) There is a faulty "W" output circuit.	Faulty W output circuit.
419	Critical	(Outdoor Unit) The "W" output on the outdoor unit has reported more than 5 errors. As a result, the system has shutdown the outdoor unit.	W output hardware fault count reached 5 strikes.
420	Critical	(Air Handler) The heat pump defrost cycle has taken more than 20 minutes to complete.	Defrost cycle lasts longer than 20 minutes. Check heat pump operation. Cleared when W1 signal is removed. Applicable only in communicating mode with non-communicating heat pump.
421	Critical	(Outdoor Unit) The "W" output terminal on the outdoor unit is not wired correctly.	Voltage sensed on W output terminal when Y1 out is deactivated.
700	Moderate	(Stat) The temperature sensor in the thermostat is not working properly.	Recalibrate thermostat to clear. Replace thermostat if needed.
701	Moderate	(Stat) The thermostat is reading indoor temperatures above the pre-programmed limit.	Recalibrate thermostat to clear; cool thermostat; adjust setpoint. Replace thermostat, if needed.
702	Moderate	(Stat) The thermostat is reading indoor temperatures below the pre-programmed limit.	Recalibrate thermostat to clear; warm thermostat; adjust setpoint. Replace thermostat, if needed.
703	Moderate	(Stat) The humidity sensor in the thermostat is not working properly.	Recalibrate thermostat to clear; adjust setpoint. Replace thermostat, if needed.
704	Moderate	(Stat) The thermostat is reading indoor humidity levels above the pre-programmed limit.	Recalibrate thermostat to clear. Replace thermostat, if needed.
705	Moderate	(Stat) The thermostat is reading indoor humidity levels below the pre-programmed limit.	Recalibrate thermostat to clear. Replace thermostat, if needed.
Ohm Check	—	The ohm reading in the system is either too high or too low.	Ohm reading between i+ and i- anywhere on the RSBus with supply power off should be between 70 and 90 ohms. If above 90 ohms, check and repair wiring, splices or other wiring defects that may be causing the excessive resistance. If less than 70 ohms, check for shorted wires.

Table 6. Troubleshooting Tips		Bold text indicates a button, or text display on the thermostat.	
No.	Issue / Problem	Possible Cause	Corrective Action / Comments
1	<ul style="list-style-type: none"> - No electric heat operation. - The thermostat system setting does not offer a emerg. heat choice on an HP system. - The thermostat does not offer any "heat" choice on an AC system with air handler with electric heat. 	Electric heat was not manually configured at the Air Handler Control (AHC) before the Comfort Sync™ system discovery process at initial power-up.	<ul style="list-style-type: none"> - Manually configure to discover the electric heat section(s) on the air handling (see Page 64 or Air Handler manual for details). - Re-setup the Comfort Sync system by selecting the setup button in the Installer program and press start to begin system discovery; then reconfigure the system.
2	Thermostat Displays System Waiting message and the furnace does respond to a heating demand (no red critical alert icon or alert messages are displayed on the thermostat).	The furnace is in "watchguard" mode (moderate alert) and will not display the red critical alert icon nor be displayed in the homeowner alert button.	<ul style="list-style-type: none"> - Go to the installer program alert button to view all alerts and details about those alerts. - If the furnace is in "watchguard" mode, the furnace can be reset from the Home screen by setting the thermostat system settings to off for 20 sec, then back to heat. Then initiate a new heat demand.
3	Outdoor temperature is not displayed on the thermostat.	Outdoor Temp Display must be enabled to display the outdoor temperature on the home screen.	On the home screen, press the right arrow (➡) then press the display settings button. Click on outdoor temp display button to toggle ON.
4	A humidifier was added to the system as non-communicating equipment and the thermostat does not provide the ability to adjust the RH setpoint.	Humidification Control Mode is set for "Display only" which will not allow the Comfort Sync system to control the humidifier.	<ul style="list-style-type: none"> - In the installer program, select the equipment button. Select "System" from the device list using the up/down arrows and press the edit button. Use up/down arrows to select Humidification Control Mode from the list. Select the desired humidifier control mode: Basic, Precision, or Dew Point. (Basic is the most popular) and press the save button. Follow the red instructions then exit the system. - If Humidification Control Mode is not offered as a menu item choice, the Humidifier must be added to the Comfort Sync system using the Add or Remove Non-communicating equipment screen under the thermostat installer program in the setup button.
5	The non-communicating outdoor unit is part of the system, but the thermostat does not display the outdoor unit.	The outdoor unit was not added as a non-communicating unit during initial system setup.	In the thermostat installer program select the setup button and follow the on screen instructions until you reach the Add or Remove Non-communicating equipment screen; press yes . Select Outdoor Unit Type from the menu and press the edit button. Select 1 Stage AC Unit or 2 Stage AC Unit and press save . Follow the red instructions then exit the system.

table continued on next page

Table 6. Troubleshooting Tips		Bold text indicates a button, or text display on the thermostat.	
No.	Issue / Problem	Possible Cause	Corrective Action / Comments
6	High Balance Point and Low Balance Point are not listed as a menu item to adjust the setpoint on the thermostat of the heat pump system.	Balance Point Control must be enabled to display as the High Balance Point and Low Balance Point in the menu and provide the ability for the installer to adjust the setpoint.	<ul style="list-style-type: none"> - In the installer program select the equipment button, then scroll down to system device to System and press edit. Scroll down the menu item choices to Balance Point Control and press edit. Select enable and press save. High Balance Point and Low Balance Point are now listed; adjust the balance point settings and press save. - If Balance Point Control is not shown as a menu item choice, the system is not connected to Wi-Fi or does not have/recognize an outdoor sensor or the system is not a heat pump.
7	Comfort Sync thermostat does not show a choice for Dew Point Control Humidification mode (only Basic and Precision choices).	Dew Point Control will only be displayed if the system has an outdoor sensor.	<ul style="list-style-type: none"> - Add an outdoor sensor to the system and connect to the outdoor sensor terminals on the indoor unit. - Comfort Sync system is not able to read the outdoor temperature sensor in the Comfort Sync outdoor unit, check outdoor sensor.
8	The Comfort Sync does not display an alert code message, but the furnace or unit control displays a diagnostic code.	The red Critical Alert icon and homeowner alert button do not display non-critical alerts.	Go to the installer program alert button to view all alerts and details about those alerts.
9	The Comfort Sync thermostat does not display the Model # and/or Serial # indoor or outdoor unit.	The Comfort Sync control was replaced with a replacement control before the Comfort Sync system was initially setup or configured.	<ul style="list-style-type: none"> - Replacement Comfort Sync controls do not have the Model # or Serial # loaded in the control. - The Model # and Serial # cannot be added to the control. - System will still operate normally.
10	A non-communicating 2-stage outdoor unit was added to the system but the unit only runs in 2nd stage.	The "W915 2 Stage Compr" clip-pable option link on the furnace or air handler control must be cut when used with a non-communicating 2-stage outdoor unit.	Cut the "W915 2 Stage Compr" option link on the furnace or air handler control.
11	Transfer the Model #, Serial # and system settings to a replacement control.	The Comfort Sync system is capable of copying settings from the previous configuration to the new compatible device (control) found.	Reconfigure the system using the installer program and select the setup button. The system will go through the system discovery process. The thermostat will display missing devices (old control) and found compatible devices (new control). Press the next button to accept the new device and copy the settings. Thermostat will display Settings were copied after successfully copying the information to the new control. See section title "Reconfiguring a system" in this manual.

table continued on next page

Table 6. Troubleshooting Tips		Bold text indicates a button, or text display on the thermostat.	
No.	Issue / Problem	Possible Cause	Corrective Action / Comments
12	Determine the actual Software version of the thermostat or one of the Comfort Sync unit controls.	Comfort Sync software is stored in the control and can be retrieved.	From the home screen click the right arrow ⏪ then click service info button; then click the thermostat info button; (display shows model & serial numbers and hardware, software, Wi-Fi revision information).
13	The Comfort Sync thermostat shows an error code related to the outdoor sensor and or the DAS even after removing these optional accessories.	The outdoor sensor and discharge sensor are options, however if the system was setup with the sensor in place, the Comfort Sync system will see an open sensor reading if it is disconnected.	<ul style="list-style-type: none"> - Disconnect the outdoor sensor or discharge sensor. - Using the installer program, reset the system by selecting setup button and follow the screen prompts as the thermostat goes through a new system discovery.
14	The Comfort Sync thermostat will not provide me a choice to add a non-communicating heat pump to a gas furnace.	The Comfort Sync system does not have the ability to control a non-communicating heat pump on a dual fuel system.	Replace the Comfort Sync™ thermostat with a conventional thermostat that has a dual fuel control mode.
15	During system discovery , the thermostat displays a message Thermostat is unable to communicate to system components .	The thermostat was not successful in communicating to the indoor unit.	<ul style="list-style-type: none"> - Verify the indoor unit has a Comfort Sync communicating control. - Check wiring connections at R, i+, i- and C at the indoor unit and thermostats. - Check R, i+, I-, C wires for open/shorts.
16	Temperature or humidity calibration does not respond to calibration changes.	Temperature/Humidity calibration changes will change display 1°F or 1% RH every 3 minutes.	Allow the system to stabilize and complete the calibration mode due to the time delay. A 5°F calibration change will take 15 minutes to calibrate the display.
17	The installer adjustable settings used to configure the system are not listed in the equipment button under the Thermostat 49W95 (only Temp Reading Calibration and Humidity Reading Calibration are listed as menu items).	The adjustable system configuration settings are listed in the equipment button under System .	<ul style="list-style-type: none"> - In the installer program select the equipment button and choose System from system device and press edit. - Over 25 installer adjustable settings are provided including balance point, humidification control, dehumidification modes, stage differentials and delays.

table continued on next page

Table 6. Troubleshooting Tips		Bold text indicates a button, or text display on the thermostat.	
No.	Issue / Problem	Possible Cause	Corrective Action / Comments
18	During the cooling mode the displayed air volume on the indoor control is substantially lower than expected.	The system may be following "the cooling ramping" profile or may be in "the dehumidification mode".	<ul style="list-style-type: none"> - During the default cooling ramping profile the blower will run for 7.5 minutes at 82% of the cooling air volume. If the "cooling ramping profile" is selected, the system will ramp to 100% after 7.5 minutes. - The dehumidification mode will run the system at 70% of the cooling air volume which will be in addition to the air volume reduction provided during the ramping profile. During the dehumidification mode, a "d" will be displayed on the furnace or air handler control.
19	The Indoor unit is not providing the expected air volume according to the cfm shown on the indoor unit control.	<ul style="list-style-type: none"> - Indoor unit air volume settings in the Comfort Sync thermostat are not correct. - System is operating in the cooling mode and following the cooling ramping profile or dehumidification air volume. 	<ul style="list-style-type: none"> - In the installer program select the equipment button and choose the furnace or air handler from the system devices list and press edit. Verify/set the correct air volume for heating and cooling modes. - If in the cooling mode check for cooling ramp mode or dehumidification mode as in #18.
20	<ul style="list-style-type: none"> - No second stage cooling is provided on a Comfort Sync outdoor unit. - Space temperature is above second stage differential and has run in first stage a long time. - No red Critical Alert icon or alert is displayed in the homeowner alert button. 	The red Critical Alert icon and homeowner alert button do not display non-critical alerts.	<ul style="list-style-type: none"> - Go to the installer program alert button to view all alerts and details about those alerts. - Look for alert code 401 (Compressor Long On Cycle) which indicates compressor ran more than 18 hours continuous and will lock out 2nd stage compressor. - Cycle indoor power off and back on, alert code 401 will clear within a few minutes.
21	No weather being displayed.	Comfort Sync™ not communicating with router.	Make sure Wi-Fi is enabled (see Page 24).
22	Unable to complete Wi-Fi router / internet connection	Refer to 507094-01 <i>Wi-Fi Troubleshooting checklist for Comfort Sync™ thermostat.</i>	

Wiring Diagrams

Comfort Sync Communicating System Wiring

DAS NOTE - The discharge air sensor is intended to be mounted downstream of the furnace heat exchanger and air conditioning coil. It must be placed in free airflow, where other accessories (such as humidifiers, UV lights, etc.) will not interfere with its accuracy. Wiring distance between the IFC or AHC and the discharge air sensor should not exceed 10ft when wired with 18-gauge thermostat wire.

OAS NOTE - Wiring distance between the IFC or AHC and the outdoor temperature sensor should not exceed 200ft when wired with 18-gauge thermostat wire.

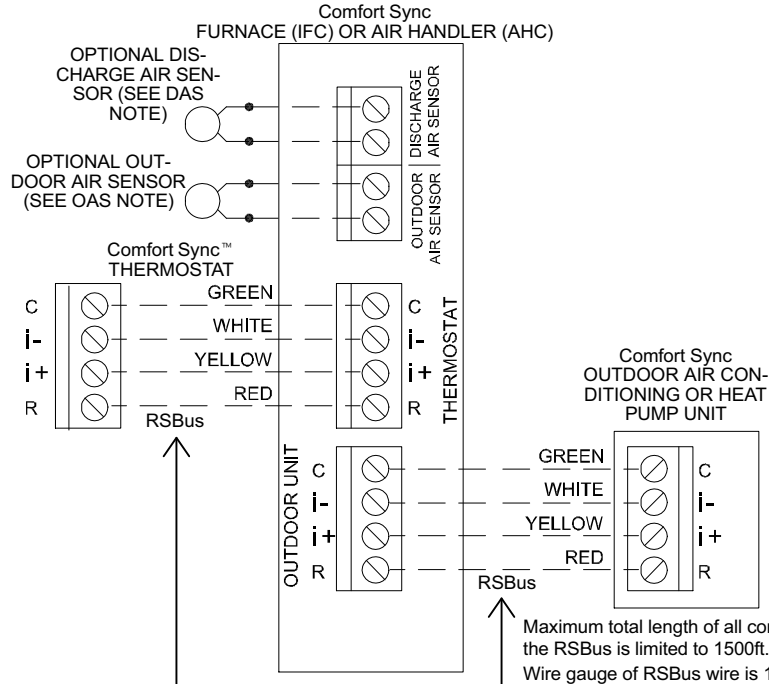

HP/AC

Comfort Sync™ Thermostat
 Comfort Sync Indoor Furnace or Air Handler
 Outdoor Condensing Unit or Heat Pump

Wiring Diagrams

Comfort Sync Communicating Indoor/non-Communicating Outdoor System Wiring

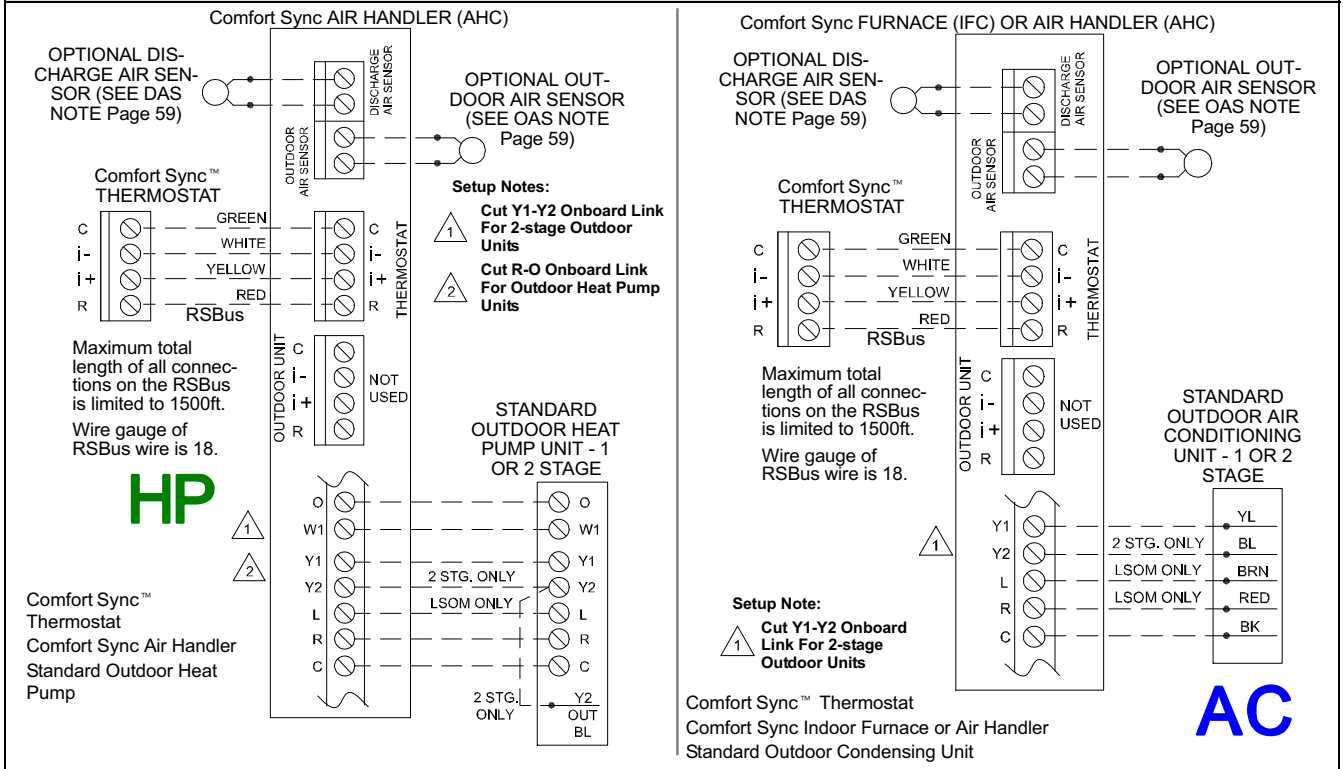

Optional Accessories Wiring

for use with any Comfort Sync system

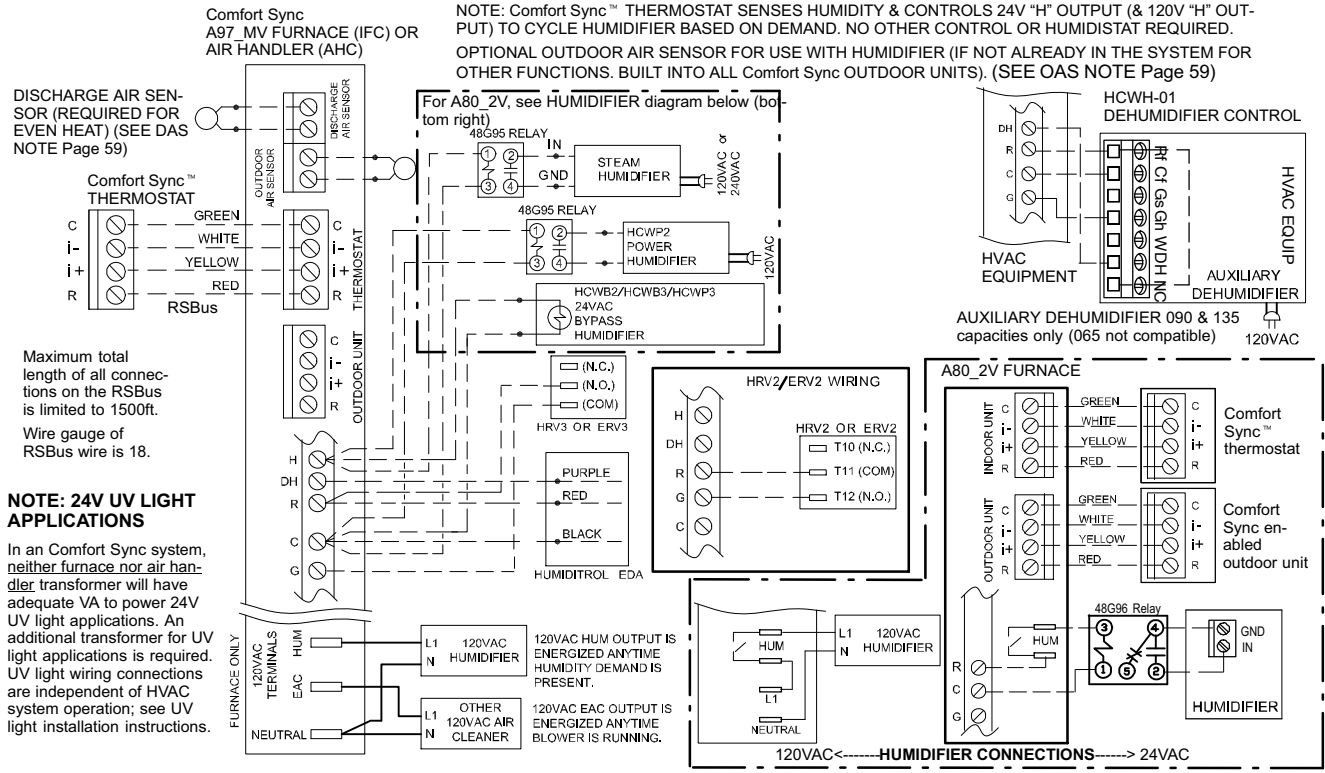

Optional Accessories Wiring

for use with any Comfort Sync system

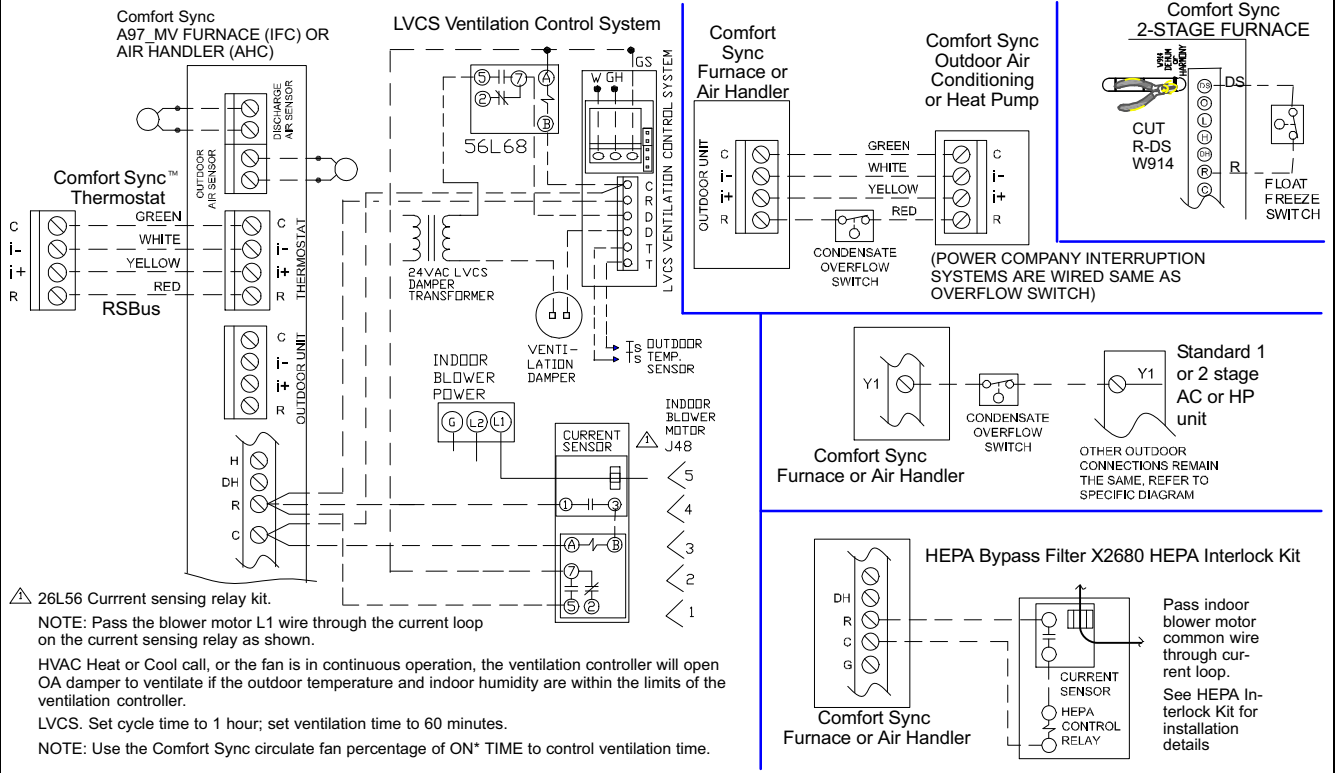

Thermostat wire termination in communicating system

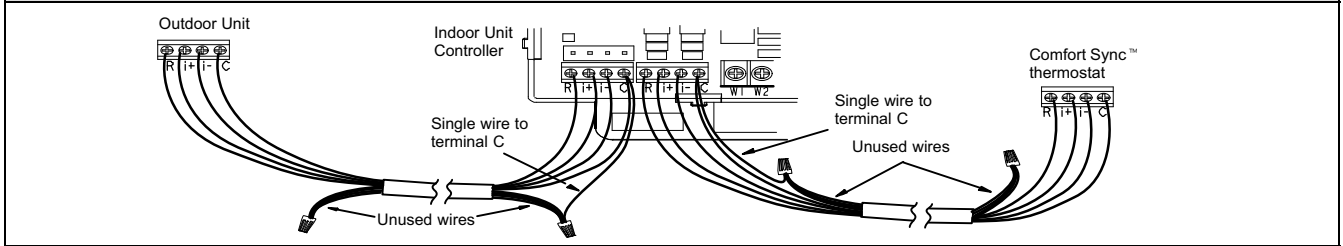

Communicating systems using the Comfort Sync™ thermostat require four thermostat wires between the thermostat and the furnace/air handler control and four wires between the outdoor unit and the furnace/air handler control. When a thermostat cable with more than four wires is used, the extra wires must be properly connected to avoid electrical noise. The wires must not be left disconnected.

Use wire nuts to bundle the unused wires at each end of the cable. A single wire should then be connected to the indoor unit end of the wire bundle and attached to the "C" terminals as shown in the diagram above.

This is not an issue in non-communicating systems.

Configuring heat strips on Air Handler Control (AHC)

IMPORTANT: After electric heat strips are installed, the Air Handler Control (AHC) must be manually configured to detect the number of electric heat sections. (SEE ALSO Air Handler installation manual for configuration details.)

To configure the heat strips so that they will be detected by the thermostat:

- Power must be applied to the air handler but NOT to the thermostat. Remove thermostat from baseplate or remove wires to thermostat at the air handler.
- On the air handler control (AHC), unit should be in idle mode (decimal blinks at 1 Hertz—0.5 second ON, 0.5 second OFF).
- Select field test mode—press and hold the pushbutton until solid “_” appears; release button. Display will blink.
- Press the pushbutton and wait for the display LED to show “H” (capital H), then release the button.
- The AHC cycles the indoor blower motor “on” to the selected heat speed and stages the electric heat relays “on” and “off” to automatically detect the number of electric heat sections. The AHC stores the number of electric heat sections, then automatically exits “Field Test Mode”.
- At this point, the Comfort Sync™ will now detect the heat strip information stored in the AHC.

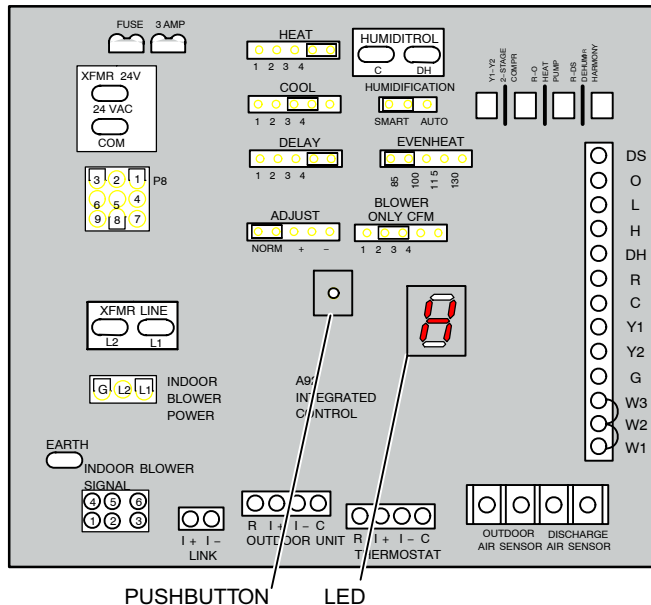

Setting up typical systems—FURNACE & AIR CONDITIONING UNIT

Comfort Sync-enabled furnace & Comfort Sync-enabled air conditioner

A Comfort Sync-enabled gas furnace (A97_SMV, A80_S2V) with a Comfort Sync-enabled AC (4SCU16LS or 4SCU18LS) unit.

1. **Wiring**—See **Communicating System Wiring** diagram on Page 59 and **Optional Accessories Wiring** (Page 61) for any accessories being installed with the system.
 - 4-conductor thermostat wire from the ComfortSync™ thermostat to the gas furnace (R, i+, i-, C)
 - 4-conductor thermostat wire from the integrated furnace control (IFC) terminal strip to the Comfort Sync-enabled AC unit (R, i+, i-, C)
 - Wiring as required for accessories
2. **DO NOT** cut any option link on air handler control.
3. After the entire system is wired, power up the system; the Comfort Sync™ thermostat will check the system for installed communication devices.
4. On the thermostat, go past the “Add or remove non-communicating devices” to the “To adjust a setting” screen.
5. Use the arrows to select “Furnace” from system devices list; press **edit**. From this Furnace screen you will have access to the various air-flow settings. Set the system air volumes according to the needs of the home. When you change certain settings, the system will prompt you to “please view and save all red settings”. Use the arrows to select the

red settings and press **edit**. Either make changes or not, but press **save** either way. The red settings will go away after pressing **save**. When all CFM settings are complete, press the **back** button. Press **next step** to advance to the tests button.

6. Using up/down arrows, select the test options individually (if so desired, you may choose to TEST ALL) and press the **select** button. (If selecting individual tests, repeat until you have selected all you intend to run.)
7. Press the **start** button. Confirm the AC unit is electrically energized and operational. Press **done**.
8. Exit the installer setup mode by selecting the **EXIT** button.

TIPS

- An outdoor temperature sensor is provided in a Comfort Sync-enabled air conditioning unit. To display the outdoor temperature on the home screen of the thermostat, you must turn on (or off) the “Outdoor Temp Display”. From the Home screen, press **press for more** area and select the **HELP** icon. Press the **user preferences** box and scroll down to “Outdoor Temp Display”. Press the **modify** button and use the up/down arrows to select **On** (or Off) and then press the **save** button. Press **done** to return to the Home screen.
- Turn the Indoor Humidity Display on and off in a similar manner as above.

Comfort Sync-enabled furnace & non-communicating air conditioner

A Comfort Sync-enabled gas furnace (A97_SMV, A80_S2V) with a conventional non-communicating air conditioner.

1. **Wiring**—See **Communicating Indoor/Non-Communicating Outdoor System Wiring** diagram on Page 59 and **Optional Accessories Wiring** (Page 61) for any accessories being installed with the system.
 - 4-conductor thermostat wire from the ComfortSync™ thermostat to the gas furnace (R, i+, i-, C)
 - Conventional thermostat wire with 2 to 4 conductors from the Comfort Sync furnace terminal strip to the AC unit (Y1, C, & on some models, R & Y2)
 - Wiring as required for accessories
2. Cut option link “2-stage compr” (Y1 to Y2, W915) on furnace control on two-stage AC units only.
3. After the entire system is wired, power up the system; the Comfort Sync™ thermostat will check the system for installed communication devices.
4. In the installer setup button, select “Add or Remove non-communicating equipment” by using the **yes** button.
5. Select the “Outdoor Unit Type” from the device list using the up/down arrows and press the **edit** button. Then select the AC type (1-stage AC or 2-stage AC) and press the **save** button.
6. Select the outdoor unit capacity and minimum outdoor unit capacity (2-stage only). Press **save** after editing each setting. Press **back** when finished to return to the adjust screen.

7. Use the arrows to select “Furnace” from system devices list; press **edit**. From this Furnace screen you will have access to the various air-flow settings. Set the system air volumes according to the needs of the home. When you change certain settings, the system will prompt you to “please view and save all red settings”. Use the arrows to select the red settings and press **edit**. Either make changes or not, but press **save** either way. The red settings will go away after pressing **save**. When all CFM settings are complete, press the **back** button. Press **next step** to advance to the tests button.
8. Using up/down arrows, select the test options individually (if so desired, you may choose to TEST ALL) and press the **select** button. (If selecting individual tests, repeat until you have selected all you intend to run.)
9. Press the **start** button. Confirm the AC unit is electrically energized and operational. Press **done**.
10. Exit the installer setup mode by selecting the **EXIT** button.

TIPS

- If the thermostat “System Setting” only shows “heat only” or “off” choices and does not offer a choice for “cooling” you must “Install” the non-communicating air conditioning unit. Select “Add or Remove non-communicating” under the setup button in the Installer Section. Select “Outdoor Unit Type”, press the **edit** button and then choose “1 Stage AC” or “2 Stage AC” and press the **save** button.
- On two-Stage Air Conditioners you must cut the “W915 2 Stage Compr” link on the furnace control.

Setting up typical systems—FURNACE & HEAT PUMP (DUAL FUEL)

Comfort Sync-enabled Furnace & Comfort Sync-enabled HP unit (Dual fuel)

Dual fuel system using a Comfort Sync-enabled gas furnace (A97_SMV, A80_S2V) with a Comfort Sync-enabled heat pump (4SHP16LS or 4SHP18LS).

1. **Wiring**—see **Communicating System Wiring** diagram on Page 59 and **Optional Accessories Wiring** (Page 61) for any accessories being installed with the system.
 - 4-conductor thermostat wire from the ComfortSync™ thermostat to the gas furnace (R, i+, i-, C)
 - 4-conductor thermostat wire from the furnace terminal strip to the Comfort Sync-enabled HP (R, i+, i-, C)
 - Wiring as required for accessories
2. **DO NOT** cut any option link on furnace control.
3. After the entire system is wired, power up the system; the Comfort Sync™ thermostat will check the system for installed communication devices.
4. On the thermostat, go past the “Add or remove non-communicating devices” to the “To adjust a setting” screen. Select “System” from the device list using the up/down arrows and press the **edit** button
5. Select Balance Point Control and press **edit**. Use the down arrow to select “Enabled” and press **save**. High and Low Balance Points will appear in red.
6. Complete Balance Point Control by editing the High and Low Balance Points. It is not necessary to change the defaults, but you must save each setting. The red settings will go away after pressing **save**. Press the **back** button to return to the adjust screen.
7. Use the arrows to select “Furnace” from system devices list; press **edit**. From this Furnace screen you will have access to the various air-flow settings. Set the system air volumes according to the needs of the home. When you change certain settings, the system will prompt you to “please view and save all red settings”. Use the arrows to select the red settings and press **edit**. Either make changes or not, but press **save** either way. The red settings will go away after pressing **save**.

When all CFM settings are complete, press the **back** button. Press **next step** to advance to the tests button.

8. Test the system operation and confirm the HP unit is electrically energized and operational. Press **done**.
9. Exit the installer setup mode by selecting the **EXIT** button.

TIPS

- High & Low Balance points are enabled and adjusted under the installer section of the thermostat. In the equipment button select “System” and press **edit**. Scroll down to “Balance Point Control” and press **edit** and select **Enabled** and then **save**.
- An outdoor temperature sensor is provided in an Comfort Sync-enabled heat pump unit. To display the outdoor temperature on the home screen of the thermostat, you must turn on (or off) the “Outdoor Temp Display”. From the Home screen, press **press for more** area and select the **HELP** icon. Press the **user preferences** box and scroll down to “Outdoor Temp Display”. Press the **modify** button and use the up/down arrows to select **On** (or **Off**) and then press the **save** button. Press **done** to return to the Home screen.
- Turn the Indoor Humidity Display on and off in a similar manner as above.
- Gas heat is not provided to temper the air during defrost cycles.

Comfort Sync-enabled Furnace & non-communicating HP unit (Dual fuel)

NOTE - DO NOT use a conventional non-communicating heat pump unit in an Comfort Sync dual fuel system.

TIPS

- A conventional thermostat capable of controlling a dual fuel system must be selected for this type of application. Comfort Sync™ thermostats currently do not support dual fuel applications.

Setting up typical systems—AIR HANDLER & AIR CONDITIONER

Comfort Sync-enabled Air Handler & Comfort Sync-enabled Air Conditioner

A Comfort Sync-enabled air handler (BSC2M_S) with a Comfort Sync-enabled air conditioner (4SCU16LS or 4SCU18LS).

NOTE - IMPORTANT! Be sure to configure the air handler control so that heat strips (if used) information will be detected by the Comfort Sync thermostat. This must be done prior to powering up the system and thermostat.

1. Configure air handler control (AHC) for auxiliary heat strips if used.
2. **Wiring**—See **Communicating System Wiring** diagram on Page 59 and **Optional Accessories Wiring** (Page 61) for any accessories being installed with the system.
 - 4-conductor thermostat wire from the ComfortSync™ thermostat to the air handler (R, i+, i-, C)
 - 4-conductor thermostat wire from the air handler terminal strip to the Comfort Sync-enabled AC (R, i+, i-, C)
 - Wiring as required for accessories
3. **DO NOT** cut any option link on air handler control.
4. After the entire system is wired, power up the system; the Comfort Sync thermostat will check the system for installed communication devices.
5. On the thermostat, go past the “Add or remove non-communicating devices” to the “To adjust a setting” screen. Select “System” from the device list using the up/down arrows and press the **edit** button.
6. Use the arrows to select “Air Handler” from system devices list; press **edit**. From this Air Handler screen you will have access to the various airflow settings. Set the system air volumes according to the needs of the home. When you change certain settings, the system will prompt you

to “please view and save all red settings”. Use the arrows to select the red settings and press **edit**. Either make changes or not, but press **save** either way. The red settings will go away after pressing **save**. When all CFM settings are complete, press the **back** button. Press **next step** to advance to the tests button.

7. Test the system operation and confirm the system is electrically energized and operational. Particularly, test the heat strips (when used) to insure the auxiliary stages operate as designed. Press **done**.
8. Exit the installer setup mode by selecting the **EXIT** button.

TIPS

- If the thermostat “System Setting” does not offer a choice for “emerg. heat” and or the electric heat will not function; the electric heat has not been configured. Configure the electric heat as described on Page 64, or for complete detail, see the Air Handler installation instructions. Re-configure the Comfort Sync system by entering the installer program and selecting the **setup** button and following the prompts.
- An outdoor temperature sensor is provided in an Comfort Sync-enabled air conditioning unit. To display the outdoor temperature on the home screen of the thermostat, you must turn on (or off) the “Outdoor Temp Display”. From the Home screen, press **press for more** area and select the **HELP** icon. Press the **user preferences** box and scroll down to “Outdoor Temp Display”. Press the **modify** button and use the up/down arrows to select **On** (or **Off**) and then press the **save** button. Press **done** to return to the Home screen.
- Turn the Indoor Humidity Display on and off in a similar manner as above.

Comfort Sync-enabled Air Handler & conventional non-communicating Air Conditioner

A Comfort Sync-enabled air handler (BSC2M_S) with a conventional non-communicating AC unit.

NOTE - IMPORTANT! Be sure to set up the air handler control for heat strips (if used) prior to powering up the system and thermostat.

1. Configure air handler control (AHC) for auxiliary heat strips if used.
2. **Wiring**—see **Communicating Indoor / Non-Communicating Outdoor System Wiring** diagram on Page 59 and **Optional Accessories Wiring** (Page 61) for any accessories being installed with the system.
 - 4-conductor thermostat wire from the ComfortSync™ thermostat to the air handler (R, i+, i-, C)
 - Comfort Sync air handler to conventional AC (5 – 8 wires). (Y1, Y2, C, R, W1, W2)
 - Wiring as required for accessories
3. On 2-stage AC, cut the “W915 2 Stage Compr” onboard clippable link.
4. On air handler control, remove jumper between W1 & W2 for two-stage electric heat only.
5. After the entire system is wired, power up the system; the Comfort Sync thermostat will check the system for installed communication devices.
6. In the installer setup button, select “Add or Remove non-communicating equipment” by using the **yes** button.
7. Select the “Outdoor Unit Type” from the device list using the up/down arrows and press the **edit** button. Then select the AC type (1-stage AC or 2-stage AC) and press the **save** button.
8. On the thermostat, go past the “Add or remove non-communicating devices” to the “To adjust a setting” screen. Select “System” from the device list using the up/down arrows and press the **edit** button

9. Use the arrows to select “Air Handler” from system devices list; press **edit**. From this Air Handler screen you will have access to the various airflow settings. Set the system air volumes according to the needs of the home. When you change certain settings, the system will prompt you to “please view and save all red settings”. Use the arrows to select the red settings and press **edit**. Either make changes or not, but press **save** either way. The red settings will go away after pressing **save**. When all CFM settings are complete, press the **back** button. Press **next step** to advance to the tests button.
10. Test the system operation and confirm the system is electrically energized and operational. Particularly, test the heat strips (when used) to insure the auxiliary stages have been detected and are operational. Press **done**.
11. Exit the installer setup mode by selecting the **EXIT** button.

TIPS

- If the thermostat “System Setting” does not offer a choice for “emerg. heat” and or the electric heat will not function; the electric heat has not been configured. Configure the electric heat as described on Page 64, or for complete detail, see the Air Handler installation instructions. Re-configure the Comfort Sync system by entering the installer program and selecting the **setup** button and following the prompts.
- If the thermostat “System Setting” only shows “heat only” or “off” choices and does not offer a choice for “cooling” you must “Install” the non-communicating air conditioning unit. Select “Add or Remove non-communicating” under the setup button in the Installer Section. Select “Outdoor Unit Type”, press the **edit** button and then choose “1 Stage AC” or “2 Stage AC” and press the **save** button.
- On two-stage Air Conditioners you must cut the “W915 2 Stage Compr” Link on the air handler control.

Setting up typical systems—AIR HANDLER & HEAT PUMP UNITS

Comfort Sync-enabled Air Handler & Comfort Sync-enabled Heat Pump unit

A Comfort Sync-enabled air handler (BSC2M_S) with a Comfort Sync-enabled heat pump (4SHP16LS or 4SHP18LS) unit.

NOTE - IMPORTANT! Be sure to set up the air handler control for heat strips (if used) prior to powering up the system and thermostat.

1. Configure air handler control (AHC) for auxiliary heat strips if used.
2. **Wiring**—See **Communicating System Wiring** diagram on Page 59 and **Optional Accessories Wiring** (Page 61) for any accessories being installed with the system.
 - 4-conductor thermostat wire from the ComfortSync™ thermostat to the air handler (R, i+, i-, C)
 - 4-conductor thermostat wire from the air handler terminal strip to the Comfort Sync-enabled HP (R, i+, i-, C)
 - Wiring as required for accessories
3. **DO NOT** cut any option link on air handler control.
4. After the entire system is wired, power up the system; the Comfort Sync thermostat will check the system for installed communication devices.
5. On the thermostat, go past the “Add or remove non-communicating devices” to the “To adjust a setting” screen. Select “System” from the device list using the up/down arrows and press the **edit** button
6. Select Balance Point Control and press **edit**. Use the down arrow to select Enabled and press **save**. High and Low Balance Points will appear in red.
7. Complete Balance Point Control by editing the High and Low Balance Points. It is not necessary to change the defaults, but you must save each setting. The red settings will go away after pressing **save**. Press the **back** button to return to the adjust screen.

8. Use the arrows to select Air Handler from system devices list. Press edit. From this Air Handler screen you will have access to the various airflow settings. Set the system air volumes according to the needs of the home. When all CFM settings are complete, press the **back** button. Address any red settings as described in steps 6 and 7. Press **next step** to advance to the tests button.
9. Test the system operation and confirm the system is electrically energized and operational. Particularly, test the heat strips (when used) to ensure the auxiliary stages operate as designed. Press **done**.
10. Exit the installer setup mode by selecting the **EXIT** button.

TIPS

- If the thermostat “System Setting” does not offer a choice for “emerg. heat” and or the electric heat will not function; the electric heat has not been configured. Configure the electric heat as described on Page 64, or for complete detail, see the Air Handler installation instructions. Reconfigure the Comfort Sync system by entering the installer program and selecting the **setup** button and following the prompts.
- High & low balance points are enabled and adjusted under the installer section of the thermostat. In the equipment button select “System” and press **edit**. Scroll down to “Balance Point Control” and press **edit** and select **Enabled** and then **save**.
- An outdoor temperature sensor is provided in an Comfort Sync enabled heat pump unit. To display the outdoor temperature on the home screen of the thermostat, you must turn on (or off) the “Outdoor Temp Display”. From the Home screen, press **press for more** area and select the **HELP** icon. Press the **user preferences** box and scroll down to “Outdoor Temp Display”. Press the **modify** button and use the up/down arrows to select **On** (or **Off**) and then press the **save** button. Press **done** to return to the Home screen.

Comfort Sync-enabled Air Handler & conventional non-communicating Heat Pump unit

A Comfort Sync-enabled air handler (BSC2M_S) with a conventional non-communicating heat pump unit.

NOTE - IMPORTANT! Be sure to set up the air handler control for heat strips (if used) prior to powering up the system and thermostat.

1. Configure air handler control (AHC) for auxiliary heat strips if used.
2. **Wiring**—see **Communicating System Wiring diagram** on Page 59 and **Optional Accessories Wiring** (Page 61) for any accessories being installed with the system.
 - 4-conductor thermostat wire from the ComfortSync™ thermostat to the air handler (R, i+, i-, C)
 - Conventional thermostat wire with 5 to 6 conductors from Comfort Sync air handler to conventional HP (5 – 8 wires). (Y1, C, R, W1, O, and on some models Y2)
 - Wiring as required for accessories
3. On air handler control, with 2-stage HP cut the “W915 2 Stage Comp” onboard clippable link. Cut W951 between W1 & W2 for two-stage electric heat only.
4. After the entire system is wired, then powered up, the Comfort Sync™ thermostat will check the system for installed communication devices.
5. In the installer setup button, select “Add or Remove non-communicating equipment” by using the **yes** button.
6. Select the “Outdoor Unit Type” from the device list using the up/down arrows and press the **edit** button. Then select the heat pump type (1-stage HP or 2-stage HP) and press the **save** button.
7. On the thermostat, go past the “Add or remove non-communicating devices” to the “To adjust a setting” screen. Select “System” from the device list using the up/down arrows and press the **edit** button.
8. Select Balance Point Control (if outdoor sensor is installed) and press **edit**. Use the down arrow to select “Enabled” and press **save**. High and Low Balance Points will appear in red.
9. Complete Balance Point Control by editing the High and Low Balance Points. It is not necessary to change the defaults, but you must save

each setting. The red settings will go away after pressing **save**. Press the **back** button to return to the adjust screen.

10. Use the arrows to select Air Handler from system devices list. Press **edit**. From this Air Handler screen you will have access to the various airflow settings. Set the system air volumes according to the needs of the home. When all CFM settings are complete, press the **back** button. Address any red settings as described in steps 8 and 9. Press **next step** to advance to the tests button.
11. Test the system operation and confirm the system is electrically energized and operational. Particularly, test the heat strips (when used) to insure the auxiliary stages operate as designed. Press **done**.
12. Exit the installer setup mode by selecting the **EXIT** button.

TIPS

- If the thermostat “System Setting” does not offer a choice for “emerg. heat” and/or the electric heat will not function; the electric heat has not been configured. Configure the electric heat as described on Page 64, or for complete detail, see the Air Handler installation instructions. Reconfigure the Comfort Sync system by entering the installer program and selecting the **setup** button and following the prompts.
- High & low balance points are enabled and adjusted under the installer section of the thermostat. In the equipment button select “System” and press **edit**. Scroll down to “Balance Point Control” and press **edit** and select **Enabled** and then **save**.
- If an optional outdoor temperature sensor has been installed, you may display the outdoor temperature on the home screen of the thermostat. To turn on (or off) the “Outdoor Temp Display”. From the Home screen, press **press for more** area and select the **HELP** icon. Press the **user preferences** box and scroll down to “Outdoor Temp Display”. Press the **modify** button and use the up/down arrows to select **On** (or **Off**) and then press the **save** button. Press **done** to return to the Home screen.

REVISION HISTORY

Date	Revision description
07-2012	Preliminary release (Draft 1)
09-2012	Draft 2