



Hercules
INDUSTRIES

COMMERCIAL FABRICATION DIVISION

www.herculesIndustries.com

1310 W. Evans Ave. Denver, Colorado 80223

Tel. 303 937-1000 Fax. 303 937-0903

Toll Free. 1 800 356-5350

Angle Boots

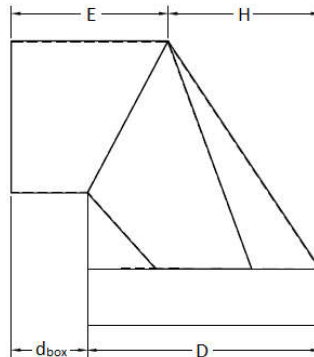
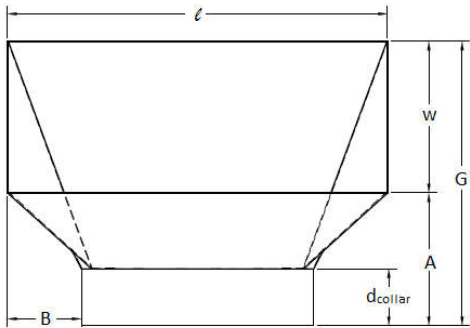

ITEM	D	d _{collar}	w	l	d _{box}	A	B	E	G	H
A305	5.125	1.5	3.25	10	1	3.625	3	3	7	3.5
A306	6.125	1.5	3.25	10	1	7.175	2	3.125	10.55	3.875
A307	7.125	1.5	3.25	10	1	3.625	1.5	4.125	7.125	4.125
A420	4.125	1.5	2.25	10	3	5.375	3.75	5.125	7.75	2.875
A440	4.125	1.5	4	10	2	4.625	3.5	4	8.625	2.125
A520	5.125	1.5	2.25	10	2	3.625	3.125	4	6	3.125
A522	5.125	1.5	2.25	12	3	3.375	4	5	5.75	3.125
A540	5.125	1.5	4	10	2	3.375	3.125	4	7.375	3.375
A542	5.125	1.5	4	12	2	3.375	3.75	4	7.375	3.25
A560	5.125	1.5	6	10	3	4	2.75	6	10	1.875
A620	6.125	1.5	2.25	10	2	3.375	2.5	4	5.75	4
A622	6.125	1.5	2.25	12	2	3.25	3.375	3.875	5.5	4.25
A640	6.125	1.5	4	10	2	3.5	2.375	4.125	7.5	3.75
A642	6.125	1.5	4	12	2	4.125	4.25	4	8.25	4.75
A740	7.125	1.5	4	10	2	5.25	1.75	5.5	9.25	3.625
A742	7.125	1.5	4	12	2.5	4.125	2.75	4.75	8.125	5.5
A844	8.125	1.5	4	14	3	4.625	3.75	5	8.625	5.625
A862	8.125	1.5	6	12	3	4	2.125	6	10	4.25

*all dimensions are in inches $\pm \frac{1}{4}$ "

- Boots constructed of **26Ga. Galvanized Steel ASTM-A653-00**
- SMACNA Standards
- All gauges and reinforcements are in compliance with 2005 SMACNA standards for duct fabrication

