



**Hercules**  
INDUSTRIES



2175 West Park Place Blvd.  
Stone Mountain, GA 30087  
Phone: 770-465-5560  
Toll Free: 800-848-2270  
Fax: 770-465-5599  
www.adpnow.com

**Dedicated 14 & 16 SEER Horizontal Coil Specification**

COIL MODEL	ADP MODEL #	DIMENSIONS A=Height & B=Depth		SUPPLY C=Height & D=Width		INLET E=Height & F=Width		LENGTH G	TXV	COIL CONNECTION	
		A	B	C	D	E	F			LIQUID	SUCTION
HC1623TB	HD14636E175B2647AP	17.5	21.25	16	19.75	16.5	20.25	26.5	TXV 410a	3/8	7/8
HC1623TC	HD14636E210B2647AP	21	21.25	19.5	19.75	20	20.25	26.5	TXV 410a	3/8	7/8
HC1645TC	HD16660E210B2647AP	21	21.25	19.5	19.75	20	20.25	26.5	TXV 410a	3/8	7/8
HC1645TD	HD16660E245B2647AP	24.5	21.25	0.23	19.75	23.5	20.25	26.5	TXV 410a	3/8	7/8

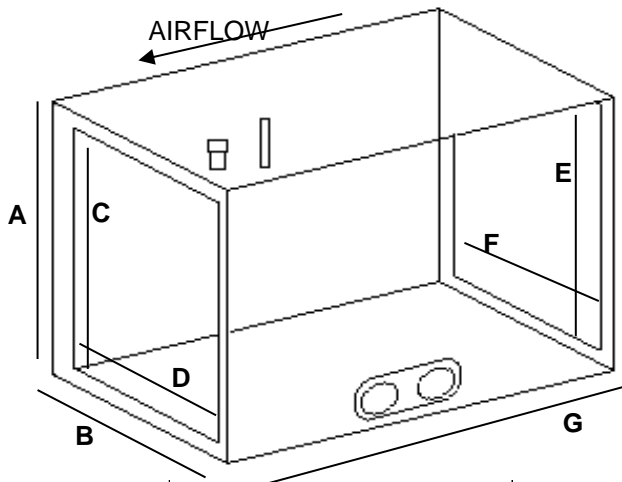

**General Specifications:**

- : Rifled copper tubing
- : Patented lance fin design
- : Ratings in conformity with ARI standard 210
- : UL Listed
- : Top, front and back panels are removable for easy service
- : Dual 3/4" FPT condensate drains on front and back
- : Coils are individually tested at 450 PSI, then pressurized and sealed
- : Florators are standard
- : Fully lined 5/8" foil faced insulation in 24gauge embossed galvanized cabinet
- : Drain pan has trough to fully drain condensate away
- : 5 year no hassle warranty
- : Factory installed R410A expansion valve

5/4/2011