

INSTALLATION INSTRUCTIONS

A97DSMV

Warm Air Gas Furnace Downflow Air Discharge



This manual must be left with the homeowner for future reference.



This is a safety alert symbol and should never be ignored. When you see this symbol on labels or in manuals, be alert to the potential for personal injury or death.

CAUTION

As with any mechanical equipment, personal injury can result from contact with sharp sheet metal edges. Be careful when you handle this equipment.

WARNING

Improper installation, adjustment, alteration, service or maintenance can cause property damage, personal injury or loss of life. Installation and service must be performed by a licensed professional installer (or equivalent), service agency or the gas supplier.

NOTICE

A thermostat is not included and must be ordered separately.

- A Comfort Sync™ thermostat must be used in communicating applications.
- In non-communicating applications, a traditional non-communication thermostat may be used.

In all cases, setup is critical to ensure proper system operation.

Field wiring for both communicating and non-communicating applications is illustrated in these instructions.

TABLE OF CONTENTS

Unit Dimensions	2	Electrical	29
Parts Arrangement	3	Integrated Control	35
Gas Furnace	4	Blower Motor Performance	43
Shipping and Packing List	4	Unit Start Up	47
Safety Information	4	Gas Pressure Measurement	48
Use of Furnace as a Construction Heater	5	High Altitude Information	49
General	6	Proper Combustion	49
Setting Equipment	6	Other Unit Adjustments	51
Filters	9	Heating Sequence of Operation	52
Duct System	9	Service	54
Pipe and Fittings Specifications	10	Planned Service	56
Joint Cementing Procedure	13	Integrated Control Diagnostic Codes	57
Venting Practices	14	Configuring Unit Size Codes	60
Vent Piping Guidelines	16	Troubleshooting	61
Condensate Piping	25	Repair Parts List	67
Gas Piping	28		



(P) 507029-01

Manufactured By
Allied Air Enterprises LLC
A Lennox International, Inc. Company
215 Metropolitan Drive
West Columbia, SC 29170

Unit Dimensions - inches (mm)

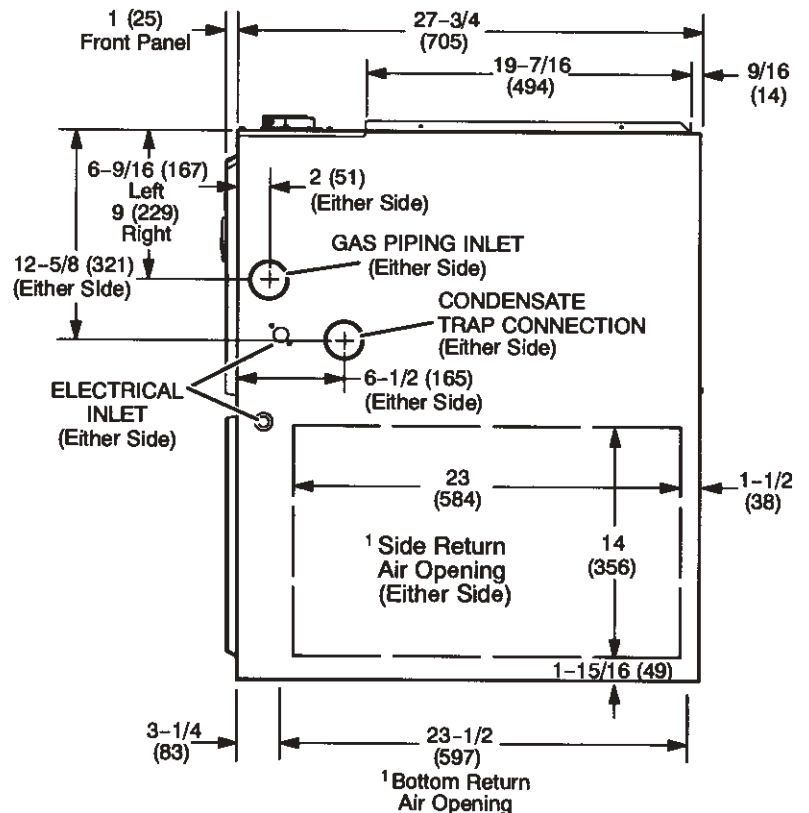
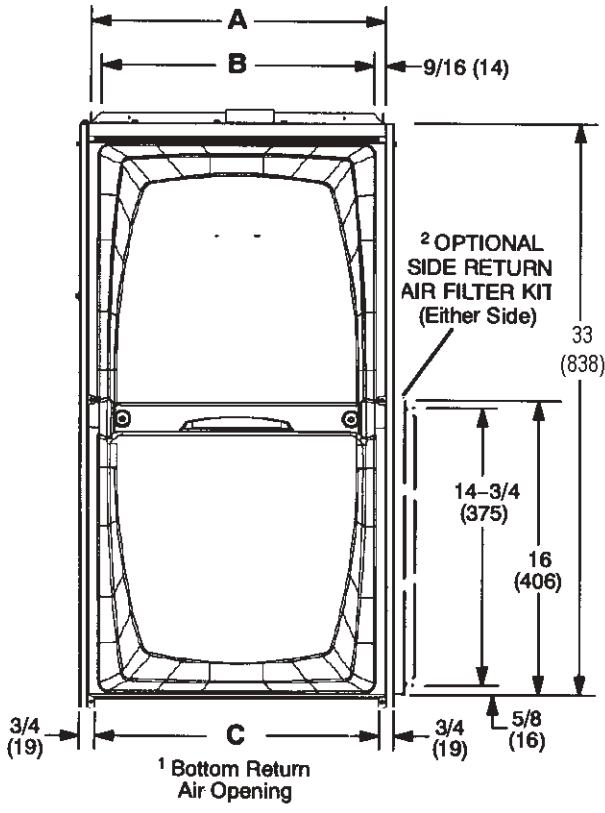
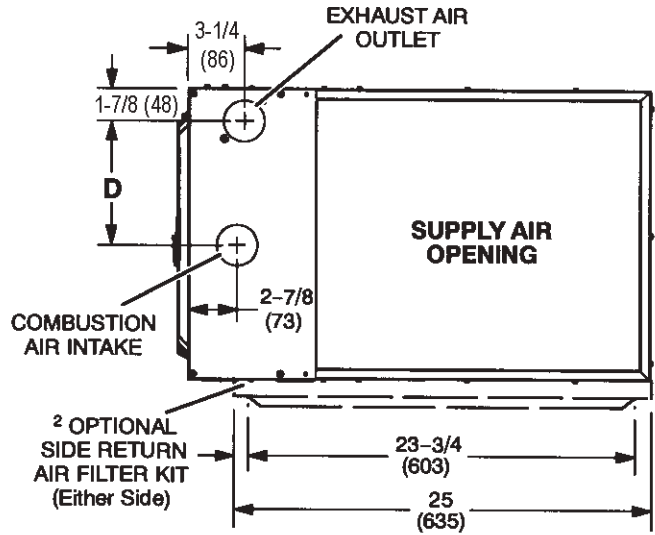

Model Number	A		B		C	
	in.	mm	in.	mm	in.	mm
A97DSMV070B12S	17-1/2	446	16-3/8	416	16	406
A97DSMV090C16S A97DSMV090C20S A97DSMV110C20S	21	533	19-7/8	505	19-1/2	495

A97DSMV Exploded View

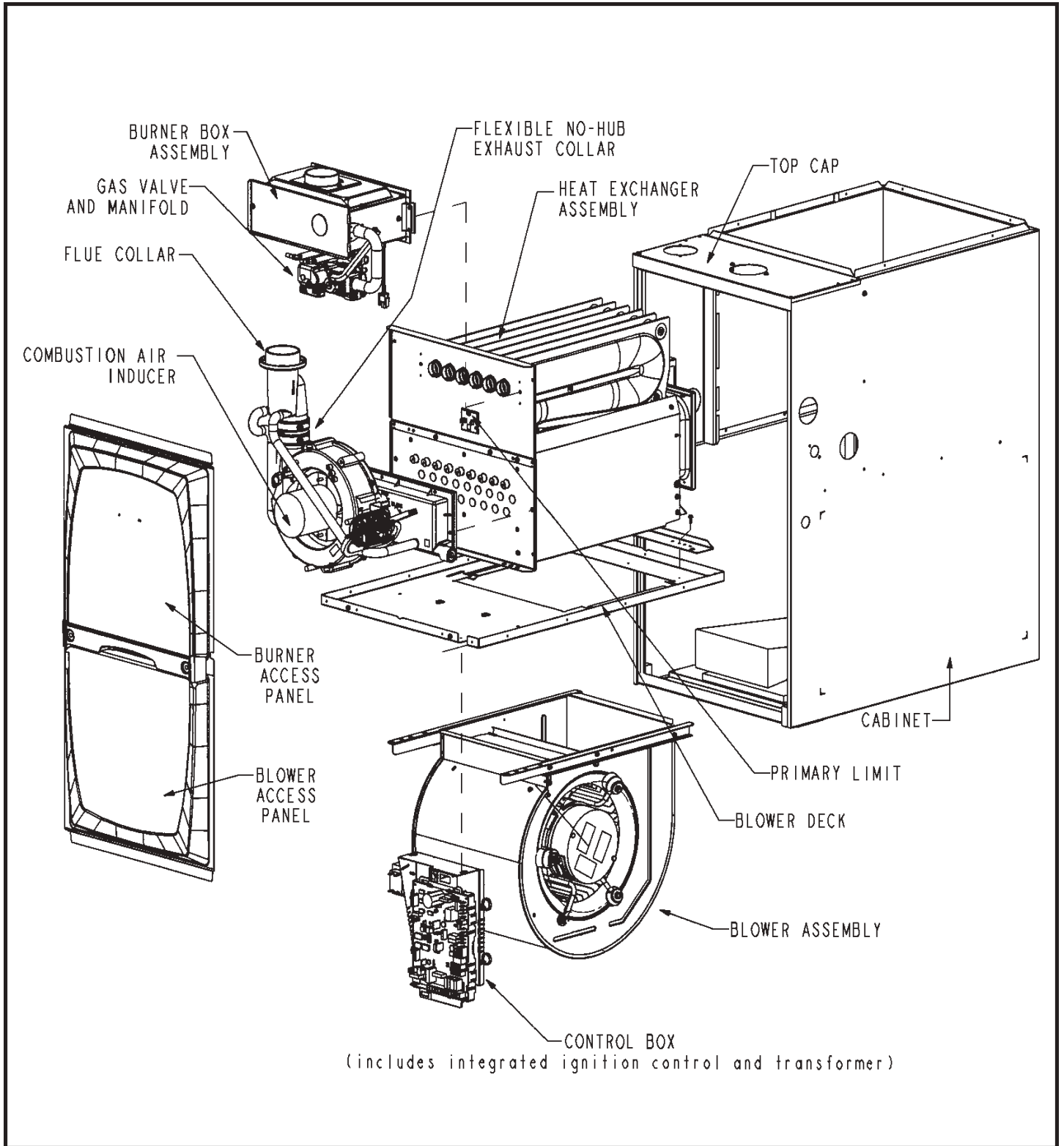

Figure 1

A97DSMV Gas Furnace

The A97DSMV Category IV gas furnace is equipped with a variable capacity, variable speed integrated control. Each A97DSMV is shipped ready for installation in the downflow air discharge position.

The furnace is equipped for installation in natural gas applications only. A change over kit must be ordered for LP/propane applications.

The A97DSMV must be installed only as a Direct Vent gas central furnace

NOTE: In Direct Vent installations, combustion air is taken from outdoors and flue gases are discharged outdoors. See Figure 2 for applications including roof termination.

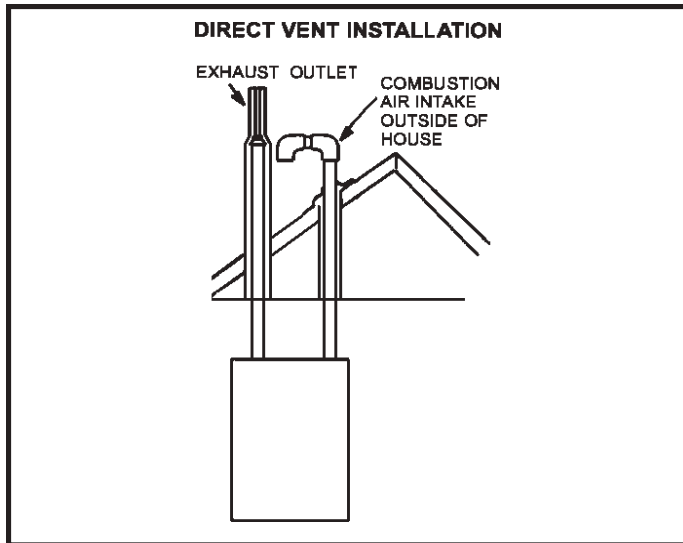

Figure 2

Shipping and Packing List

- 1 - Assembled A97DSMV unit.
- 1 - Bag assembly containing the following:
 - 1 - Snap bushing
 - 1 - Snap Plug
 - 1 - Wire tie
 - 1 - Condensate trap
 - 1 - 3/4" Threaded PVC street elbow
 - 2 - 2" Street elbows
 - 2 - Side vent sealing plates
 - 2 - Side vent sealing gaskets
 - 6 - Sheetmetal screws

Check equipment for shipping damage. If you find any damage, immediately contact the last carrier.

The following items may also be ordered separately:

- 1 - Thermostat
- 1 - Natural to LP gas conversion kit
- 1 - High altitude kit

Safety Information



DANGER OF EXPLOSION!

There are circumstances in which odorant used with LP/Propane gas can lose its scent. In case of a leak, LP/Propane gas will settle close to the floor and may be difficult to smell. An LP/Propane leak detector should be installed in all LP applications.



Improper installation, adjustment, alteration, service or maintenance can cause property damage, personal injury or loss of life. Installation and service must be performed by a licensed professional installer (or equivalent), service agency or the gas supplier.



As with any mechanical equipment, personal injury can result from contact with sharp sheet metal edges. Be careful when you handle this equipment.

Use only the type of gas approved for use with this furnace. Refer to unit nameplate.

Building Codes

In the USA, installation of gas furnaces must conform with local building codes. In the absence of local codes, units must be installed according to the current National Fuel Gas Code (ANSI Z223.1/NFPA 54). The National Fuel Gas Code is available from the **American National Standards Institute, Inc., 11 West 42nd Street, New York, NY 10036.**

Installed Locations

In Canada, installation must conform with current National Standard of Canada CSA-B149 Natural Gas and Propane Installation Codes, local plumbing or waste water codes and other applicable local codes.

The furnace is designed for installation clearances to combustible material as listed on the unit nameplate and in Figure 7. Accessibility and service clearances must take precedence over fire protection clearances.

NOTE: For installation on combustible floors, the furnace shall not be installed directly on carpeting, tile, or other combustible material other than wood flooring.

For installation in a residential garage, the furnace must be installed so that the burner(s) and the ignition source are located no less than 18 inches (457 mm) above the floor. The furnace must be located or protected to avoid physical damage by vehicles. When a furnace is installed in a public garage, hangar, or other building that has a hazardous atmosphere, the furnace must be installed according to recommended good practice requirements and current National Fuel Gas Code or CSA B149 standards.

Note: *Furnace must be adjusted to obtain a temperature rise (100% percent capacity) within the range (s) specified on the unit nameplate. Failure to do so may cause erratic limit operation and may also result in premature heat exchanger failure.*

This A97DSMV furnace must be installed so that its electrical components are protected from water.

Installed in Combination with a Cooling Coil

When this furnace is used with cooling units, it shall be installed in parallel with, or on the upstream side of, cooling units to avoid condensation in the heating compartment. With a parallel flow arrangement, a damper (or other means to control the flow of air) must adequately prevent chilled air from entering the furnace. If the damper is manually operated, it must be equipped to prevent operation of either the heating or the cooling unit, unless it is in the full **HEAT** or **COOL** setting. See Figure 3.

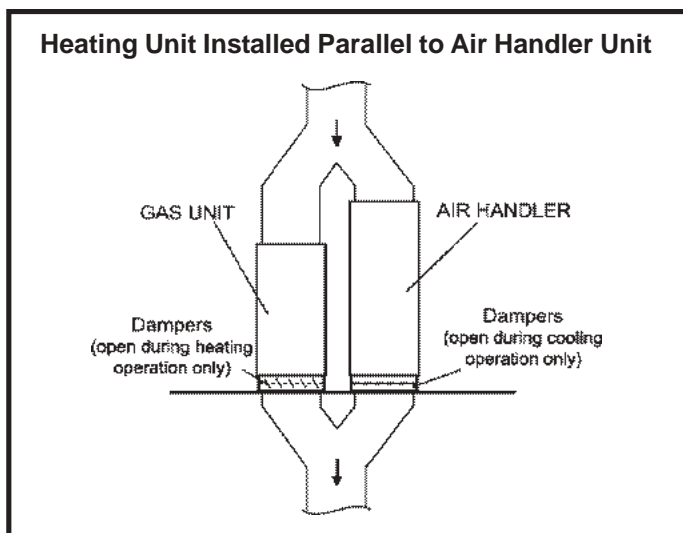

Figure 3

When installed, this furnace must be electrically grounded according to local codes. In addition, in the United States, installation must conform with the current National Electric Code, ANSI/NFPA No. 70. The National Electric Code (ANSI/NFPA No. 70) is available from the following address:

National Fire Protection Association
 1 Battery March Park
 Quincy, MA 02269

NOTE: *This furnace is designed for a minimum continuous return air temperature of 60°F (16°C) or an intermittent operation down to 55°F (13°C) dry bulb for cases where a night setback thermostat is used. Return air temperature must not exceed 85°F (29°C) dry bulb.*

In Canada, all electrical wiring and grounding for the unit must be installed according to the current regulations of the Canadian Electrical Code Part I (CSA Standard C22.1) and/or local codes.

CAUTION

Do Not set thermostat below 60° F (16° C) in heating mode. Setting thermostat below 60° F (16° C) reduces the number of heating cycles. Damage to the unit may occur that is not covered by the warranty.

The A97DSMV furnace may be installed in alcoves, closets, attics, basements, garages, crawl spaces and utility rooms.

This furnace design has not been CSA Certified for installation in mobile homes, recreational vehicles, or outdoors.

Use of Furnace as Construction Heater

These units are not recommended for use as a construction heater during any phase of construction. Very low return air temperature, harmful vapors and operation of the unit with clogged or misplaced filters will damage the unit.

These units may be used for heating of buildings or structures under construction, if the following conditions are met:

- The vent system must be permanently installed per these installation instructions.
- A room thermostat must control the furnace. The use of fixed jumpers that will provide continuous heating is not allowed.
- The return air duct must be provided and sealed to the furnace.
- Return air temperature range between 60°F (16°C) and 80°F (27°C) must be maintained.
- Air filters must be installed in the system and must be maintained during construction.

- Air filters must be replaced upon construction completion.
- The input rate and temperature rise must be set per the furnace rating plate.
- One hundred percent (100%) outdoor air must be provided for combustion air requirements during construction.
- The furnace heat exchanger, components, duct system, air filters and evaporator coils must be thoroughly cleaned following final construction cleanup.
- All furnace operating conditions (including ignition, input rate, temperature rise and venting) must be verified according to these installation instructions.

General

⚠ WARNING

The State of California has determined that this product may contain or produce a chemical or chemicals, in very low doses, which may cause serious illness or death. It may also cause cancer, birth defects or other reproductive harm.

⚠ CAUTION

These units should not be installed in areas normally subject to freezing temperatures.

These instructions are intended as a general guide and do not supersede local codes in any way. Consult authorities having jurisdiction before installation.

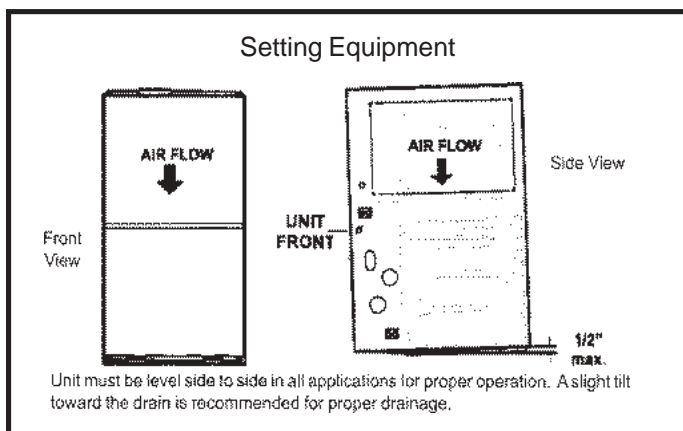

Figure 4

In addition to the requirements outlined previously, the following general recommendations should be considered when installing one of these furnaces:

- Place the furnace as close to the center of the air distribution system as possible. The furnace should also be located close to the vent termination point.
- When the furnace is installed in an attic or other insulated space, keep insulation away from the furnace.
- When the furnace is installed in an unconditioned space, consider provisions required to prevent freezing of condensate drain system.

Installation – Setting Equipment

⚠ WARNING

Do not install the furnace on its front or its back. See Figure 5. Do not connect the return air ducts to the back of the furnace. Doing so will adversely affect the operation of the safety control devices, which could result in personal injury or death.

Select a location that allows for the required clearances that are listed on the unit nameplate. Also consider gas supply connections, electrical supply, vent connection, condensate trap and drain connections, and installation and service clearances (24 inches [610 mm] at unit front). The unit must be level from side to side, for proper operation. *It is recommended to tilt the unit slightly toward the drain to insure proper drainage. See Figure 4.*

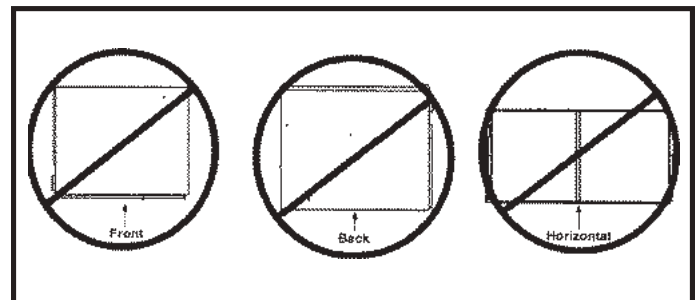

Figure 5

SETTING EQUIPMENT

UNIT MUST BE LEVEL SIDE TO SIDE IN ALL APPLICATIONS FOR PROPER OPERATION.
A SLIGHT TILT TOWARD THE DRAIN IS RECOMMENDED FOR PROPER DRAINAGE.

UPFLOW APPLICATION



FRONT VIEW

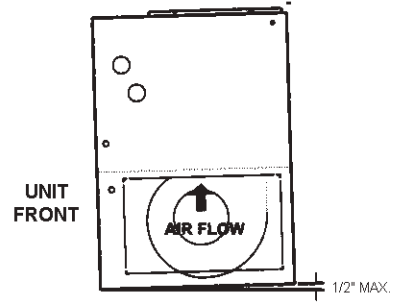

SIDE VIEW

HORIZONTAL APPLICATION

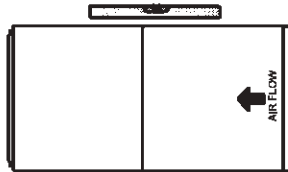

FRONT VIEW



END VIEW

TILT THE UNIT SLIGHTLY (MAX. 1/2") FROM BACK TO FRONT TO AID IN THE DRAINING OF THE HEAT EXCHANGER.

Figure 5

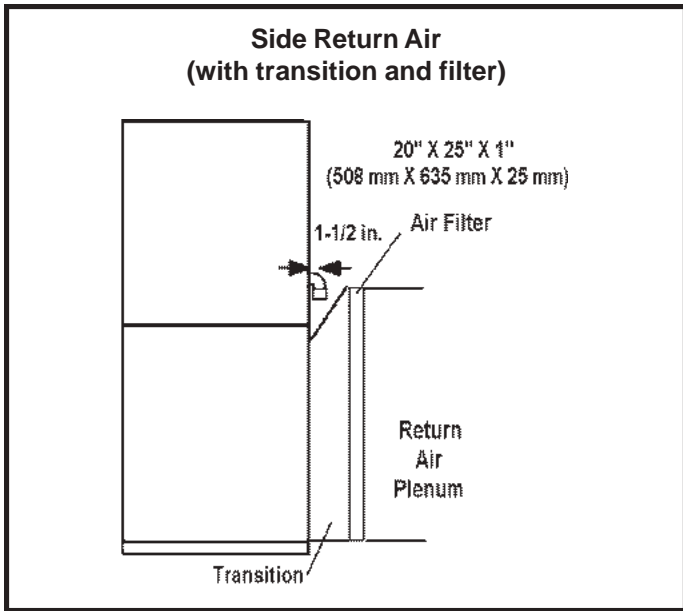

Figure 6

A97DSMV applications which include side return air and a condensate trap installed on the same side of the cabinet (trap can be installed remotely within 5 feet) require either a return air base or field fabricated transition to accommodate an optional IAQ accessory taller than 14.5". See Figure 6.

Removing the Bottom Panel
Remove the two screws that secure the bottom cap to the furnace. Pivot the bottom cap down to release the bottom panel. Once the bottom panel has been removed, reinstall the bottom cap. See Figure 7.

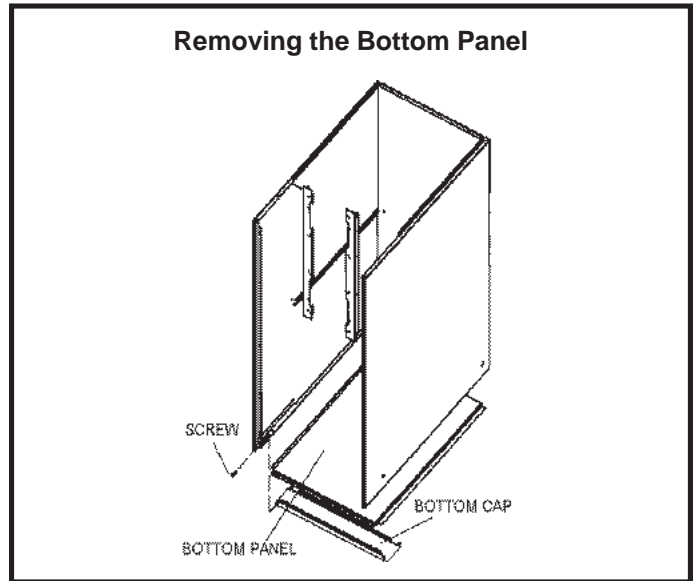

Figure 7

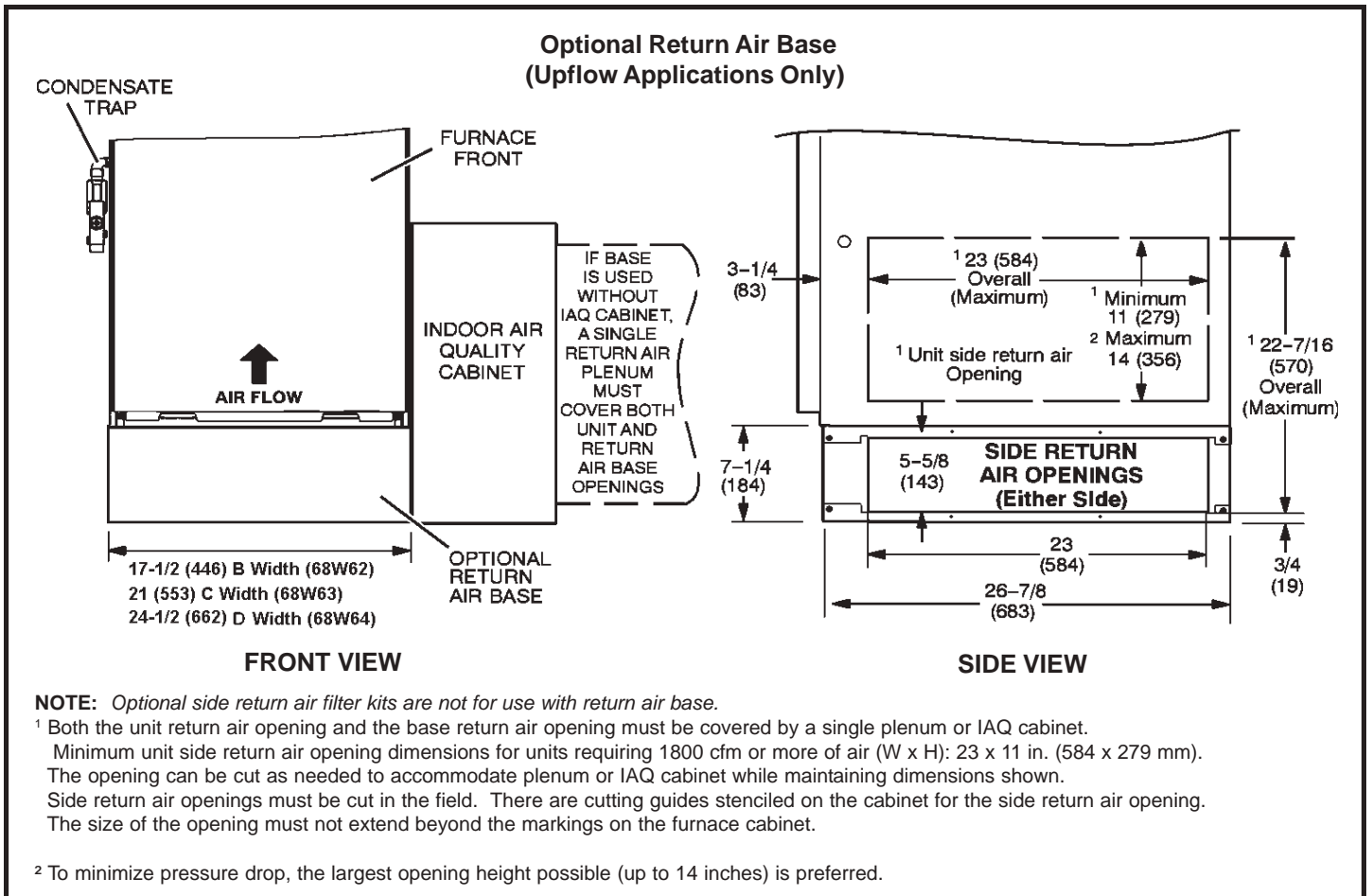

Figure 8

NOTE: Units with 1/2 hp blower motor are equipped with three flexible legs and one rigid leg. The rigid leg is equipped with a shipping bolt and a flat white plastic washer (rather than the rubber mounting grommet used with a flexible mounting leg). See Figure 9. **The bolt and washer must be removed before the furnace is placed into operation.** After the bolt and washer have been removed, the rigid leg will not touch the blower housing.

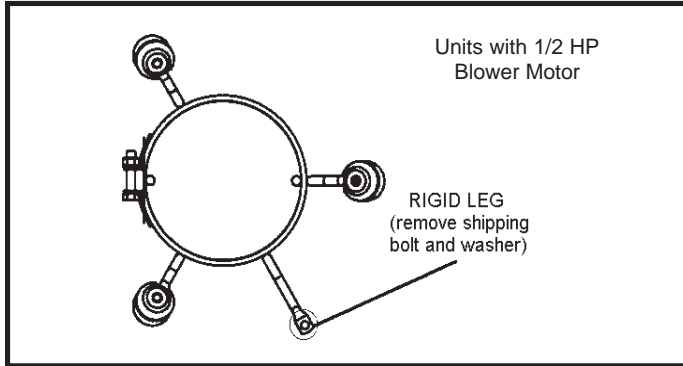

Figure 9

Allow for clearances to combustible materials as indicated on the unit nameplate. Minimum clearances for closet or alcove installations are shown in Figure 10.



Blower access panel must be securely in place when blower and burners are operating. Gas fumes, which could contain carbon monoxide, can be drawn into living space resulting in personal injury or death.



Improper installation of the furnace can result in personal injury or death. Combustion and flue products must never be allowed to enter the return air system or air in the living space. Use sheet metal screws and joint tape to seal return air system to furnace.

In platform installations with furnace return, the furnace should be sealed airtight to the return air plenum. A door must never be used as a portion of the return air duct system. The base must provide a stable support and an airtight seal to the furnace. Allow absolutely no sagging, cracks, gaps, etc.

For no reason should return and supply air duct systems ever be connected to or from other heating devices such as a fireplace or stove, etc. Fire, explosion, carbon monoxide poisoning, personal injury and/or property damage could result.

Installation Clearances

TOP

Left Side Right Side

Bottom (Floor)

Top/Plenum	1 in. (25 mm)
* Front	0
Back	0
Sides	0†
Vent	0
Floor	0‡

* Front clearance in alcove installation must be 24 in. (610 mm). Maintain a minimum of 24 in. (610 mm) for front service access.
 † Allow proper clearances to accommodate condensate trap installation.
 ‡ For installations on a combustible floor, do not install the furnace directly on carpeting, tile or other combustible materials other than wood flooring.

Figure 10

Return Air – Downflow Units

Return air can be brought in through either side of the furnace installed in a downflow application.

Markings are provided on both sides of the furnace cabinet for installations that require side return air. Cut the furnace cabinet at the maximum dimensions shown on page 2.

Setting and Upflow Unit

When the side return air inlets are used in an upflow application, it may be necessary to install shims on the bottom of the furnace.

Horizontal Applications

The A97DSMV furnace can be installed in horizontal applications with either right or left hand air discharge.

Refer to Figure 11 for clearances in horizontal applications.

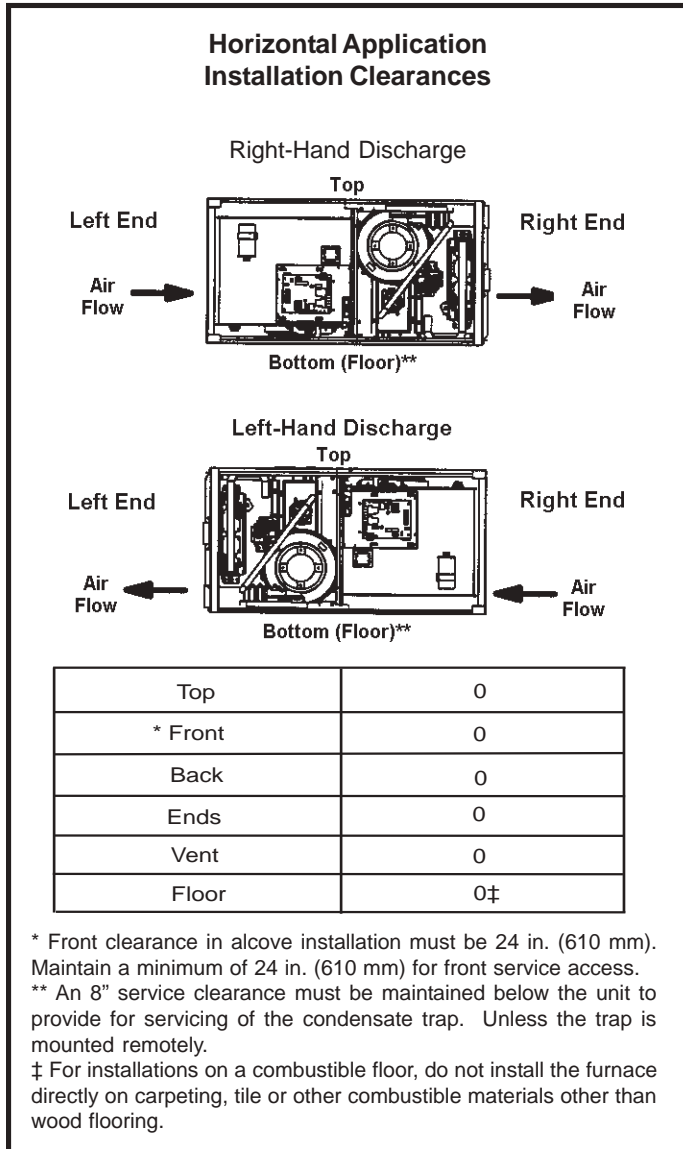

Figure 11

Suspended Installation of Horizontal Unit

This furnace may be installed in either an attic or a crawlspace. Either suspend the furnace from roof rafters or floor joists, as shown in Figure 12 or install the furnace on a platform, as shown in Figure 13. A horizontal suspension kit (51W10) may be ordered or use equivalent.

NOTE: Heavy gauge sheet metal straps may be used to suspend the unit from roof rafters or ceiling joists. When straps are used to suspend the unit in this way, support must be provided for both the ends. The straps must not interfere with the plenum or exhaust piping installation. **Cooling coils and supply and return air plenums must be supported separately.**

NOTE: When the furnace is installed on a platform in a crawlspace, it must be elevated enough to avoid water damage and to allow the evaporator coil to drain.

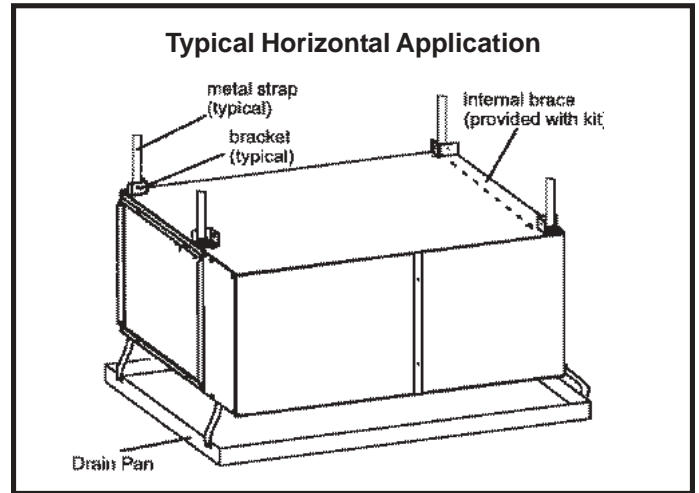

Figure 12

Platform Installation of Horizontal Unit

1. Select location for unit keeping in mind service and other necessary clearances. See Figure 11.
2. Construct a raised wooden frame and cover frame with a plywood sheet. If unit is installed above finished space, fabricate an auxiliary drain pan to be installed under unit. Set unit in drain pan as shown in Figure 13. Leave 8 inches for service clearance below unit for condensate trap, unless trap is installed remotely.
3. Provide a service platform in front of unit. When installing the unit in a crawl space, a proper support platform may be created using cement blocks.
4. Route auxiliary drain line so that water draining from this outlet will be easily noticed by the homeowner.
5. If necessary, run the condensate line into a condensate pump to meet drain line slope requirements. The pump must be rated for use with condensing furnaces. Protect the condensate discharge line from the pump to the outside to avoid freezing.
6. Continue with exhaust, condensate and intake piping installation according to instructions.

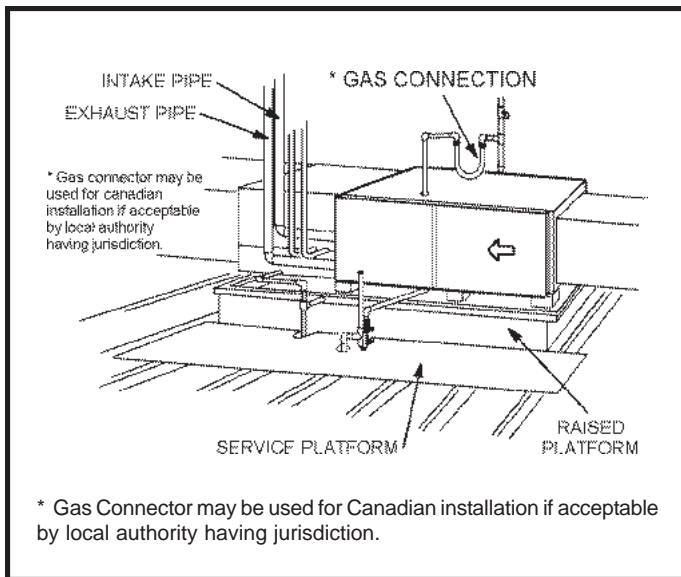

Figure 13

Return Air - Horizontal Applications

Return air must be brought in through the end of a furnace installed in the horizontal position. The furnace is equipped with a removable bottom panel to facilitate installation. See Figure 7.

Filters

This unit is not equipped with a filter or rack. A field provided filter is required for the unit to operate properly. Table 1 lists recommended filter sizes.

A filter must be in place when the unit is operating!

NOTE: *In upflow applications where side return air filter is installed on same side as the condensate trap, make sure that clearance is maintained to ensure future access to the filter access panel.*

Furnace Cabinet Width	Minimum Filter Size	
	Side Return	Bottom Return
17-1/2"	16 X 25 X 1 (1)	16 X 25 X 1 (1)
21"	16 X 25 X 1 (1)	20 X 25 X 1 (1)
24-1/2"	16 X 25 X 1 (1)	24 X 25 X 1 (1)

Table 1

Duct System

Use industry approved standards to size and install the supply and return air duct system. This will result in a quiet and low static system that has uniform air distribution.

NOTE: *Operation of this furnace in heating mode (indoor blower operating at selected heating speed) with an external static pressure which exceeds 0.8 inches w.c. may result in erratic limit operation.*

Supply Air Plenum

If the furnace is installed without a cooling coil, a removable access panel should be installed in the supply air duct. The access panel should be large enough to permit inspection (by reflected light) of the heat exchanger for leaks after the furnace is installed. If present, this access panel must always be in place when the furnace is operating and it must not allow leaks into or from the supply air duct system.

Return Air Plenum

Return air must not be drawn from a room where this furnace, or any other gas fueled appliance (i.e., water heater), or carbon monoxide producing device (i.e., wood fireplace) is installed. When return air is drawn from a room, a negative pressure is created in the room. If a gas appliance is operating in a room with negative pressure, the flue products can be pulled back down the vent pipe and into the room. This reverse flow of the flue gas may result in incomplete combustion and the formation of carbon monoxide gas. This toxic gas might then be distributed throughout the house by the furnace duct system.

Return air can be brought in through the bottom or either side of the furnace. If a furnace with bottom return air is installed on a platform, make an airtight seal between the bottom of the furnace and the platform to ensure that the unit operates properly and safely. Use fiberglass sealing strips, caulking, or equivalent sealing method between the plenum and the furnace cabinet to ensure a tight seal. If a filter is installed, size the return air duct to fit the filter frame.

Pipe and Fittings Specifications

All pipe, fittings, primer and solvent cement must conform with American National Standard Institute and the American Society for Testing and Materials (ANSI/ASTM) standards. The solvent shall be free flowing and contain no lumps, undissolved particles or any foreign matter that adversely affects the joint strength or chemical resistance of the cement. The cement shall show no gelation, stratification, or separation that cannot be removed by stirring. Refer to Table 2 for approved piping and fitting materials.

PIPING AND FITTINGS SPECIFICATIONS	
Schedule 40 PVC (Pipe)	D1785
Schedule 40 PVC (Cellular Core Pipe)	F891
Schedule 40 PVC (Fittings)	D2466
Schedule 40 CPVC (Pipe)	F441
Schedule 40 CPVC (Fittings)	F438
SDR-21 PVC or SDR-26 PVC (Pipe)	D2241
SDR-21 CPVC or SDR-26 CPVC (Pipe)	F442
Schedule 40 ABS Cellular Core DWV (Pipe)	F628
Schedule 40 ABS (Pipe)	D1527
Schedule 40 ABS (Fittings)	D2468
ABS-DWV (Drain Waste & Vent) (Pipe & Fittings)	D2661
PVC-DWV (Drain Waste & Vent) (Pipe & Fittings)	D2665
PRIMER & SOLVENT CEMENT	ASTM SPECIFICATION
PVC & CPVC Primer	F656
PVC Solvent Cement	D2564
CPVC Solvent Cement	F493
ABS Solvent Cement	D2235
PVC/CPVC/ABS All Purpose Cement For Fittings & Pipe of the same material	D2564, D2235, F493
ABS to PVC or CPVC Transition Solvent Cement	D3138
CANADA PIPE & FITTING & SOLVENT CEMENT	MARKING
PVC & CPVC Pipe and Fittings	ULCS636
PVC & CPVC Solvent Cement	
ABS to PVC or CPVC Transition Cement	

Table 2

CAUTION

Solvent cements for plastic pipe are flammable liquids and should be kept away from all sources of ignition. Do not use excessive amounts of solvent cement when making joints. Good ventilation should be maintained to reduce fire hazard and to minimize breathing of solvent vapors. Avoid contact of cement with skin and eyes.

IMPORTANT

The exhaust and intake connections are made of PVC. Use PVC primer and solvent cement when using PVC vent pipe. When using ABS vent pipe, use transitional solvent cement to make connections to the PVC fittings in the unit.

Use PVC primer and solvent cement or ABS solvent cement meeting ASTM specifications, refer to Table 2. As an alternate, use all purpose cement, to bond ABS, PVC, or CPVC pipe when using fittings and pipe made of the same materials. Use transition solvent cement when bonding ABS to either PVC or CPVC.

Low temperature solvent cement is recommended. Metal or plastic strapping may be used for vent pipe hangers. Uniformly apply a liberal coat of PVC primer for PVC.

Canadian Applications Only – Pipe, fittings, primer and solvent cement used to vent (exhaust) this appliance must be certified to ULCS636 and supplied by a single manufacturer as part of an approved vent (exhaust) system. In addition, the first three feet of vent pipe from the furnace flue collar must be accessible for inspection.

Table 5 list the available exhaust termination kits.

Venting Options

This unit is shipped with vent exhaust / air intake connection at the top cap. See Figure 13. Using parts provided, the furnace may be field modified to have these connections on the right side of the furnace cabinet. See Figure 15 and follow the steps below. For left side venting order kit 87W73.

1. Remove access panels.
2. Loosen hose clamps which attach rubber fittings to the white PVC pipes inside the vestibule area, See Figure 13.
3. Loosen the clamp which secures the pipes at the blower deck. See Figure 13.
4. Remove white PVC pipes, slide up and out thru the top cap.
5. Remove the black plastic fitting in top cap which previously aligned the PVC pipes.
6. Remove the sheet metal patch plate on the side of the cabinet which covers the openings for side venting option. Save screws for reuse.

OUTDOOR TERMINATION KITS USAGE

A97DSMV	VENT PIPE DIA. (in.)	STANDARD			CONCENTRIC		
		Outdoor Exhaust Accelerator (Dia. X Length)	Outdoor Exhaust Accelerator (Dia. X Length)	Flush-Mount Kit	1-1/2" Concentric Kit	2" Concentric Kit	3" Concentric Kit
		1-1/2" X 12"	2" X 12"	51W11**	71M80 or †44W92 ††	69M29 or †44W92 ††	60L46 or 44W93 †
045	2	YES	–	YES	YES	–	–
	2-1/2	YES	–	YES	YES	–	–
	3	YES	–	YES	YES	–	–
070	2	YES	–	YES	YES	–	–
	2-1/2	YES	–	YES	YES	–	–
	3	YES	–	YES	YES	–	–
090	2	–	YES	YES	–	YES	YES
	2-1/2	–	YES	YES	–	YES	YES
	3	–	YES	YES	–	YES	YES
110	2	–	YES	YES	–	YES	YES
	2-1/2	–	YES	YES	–	YES	YES
	3	–	YES	YES	–	YES	YES
135	3	–	YES	YES	–	–	YES

* Requires field-provided and installed 1-1/2" exhaust accelerator.

** Kit 51W11 is provided with a 1-1/2" accelerator which must be used for all 45,000 and 70,000 furnace installations.

† Termination kits 44W92, 44W93, 30G28 and 81J20 approved for use in Canadian installations to meet CSA B-149 and ULC S636.

†† The 44W92 Concentric kit is provided with a 1-1/2" accelerator which must be installed on the exhaust outlet when this kit is used with the 45,000 and 70,000 furnaces.

Table 3

Joint Cementing Procedure

All cementing of joints should be done according to the specifications outlined in ASTM D2855.



DANGER OF EXPLOSION!

Fumes from PVC glue may ignite during system check. Allow fumes to dissipate for at least 5 minutes before placing unit into operation.

1. Measure and cut vent pipe to desired length.
2. Deburr and chamfer end of pipe, removing any ridges or rough edges. If end is not chamfered, edge of pipe may remove cement from fitting socket and result in a leaking joint.
3. Clean and dry surfaces to be joined.
4. Test fit joint and mark depth of fitting on outside of pipe.
5. Uniformly apply a liberal coat of PVC primer for PVC or use a clean dry cloth for ABS to clean inside socket surface of fitting and male end of pipe to depth of fitting socket.
6. Promptly apply solvent cement to end of pipe and inside socket surface of fitting. Cement should be applied lightly but uniformly to inside of socket. Take care to keep excess cement out of socket. Apply second coat to end of pipe.

NOTE: Time is critical at this stage. Do not allow primer to dry before applying cement.

7. Immediately after applying last coat of cement to pipe, and while both inside socket surface and end of pipe are wet with cement, forcefully insert end of pipe into socket until it bottoms out. Turn PVC pipe 1/4 turn during assembly (but not after pipe is fully inserted) to distribute cement evenly. **DO NOT** turn ABS or cellular core pipe.

NOTE: Assembly should be completed within 20 seconds after last application of cement. Hammer blows should not be used when inserting pipe.

8. After assembly, wipe excess cement from pipe at end of fitting socket. A properly made joint will show a bead around its entire preimeter. Any gaps may indicate a defective assembly due to insufficient solvent.
9. Handle joints carefully until completely set.

Venting Practices

Piping Suspension Guidelines

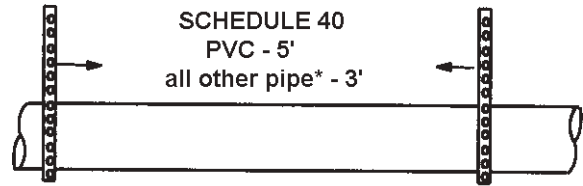

* See Table 2 for allowable pipe.

NOTE: Isolate piping at the point where it exits the outside wall or roof in order to prevent transmission of vibration to the structure.

Wall Thickness Guidelines

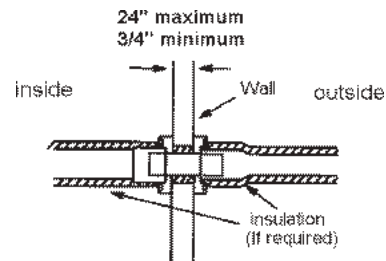

Figure 14

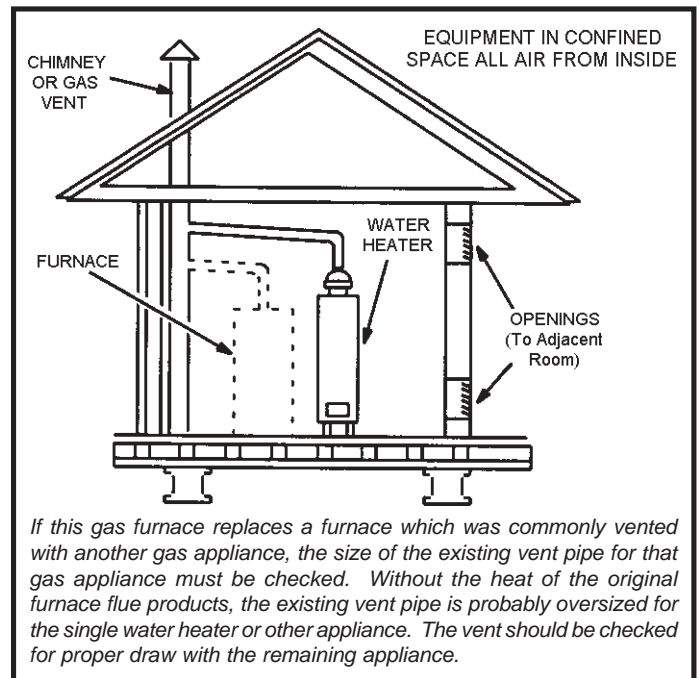



Figure 15

1. In areas where piping penetrates joist or interior walls, hole must be large enough to allow clearance on all sides of pipe through center of hole using a hanger.
2. When furnace is installed in a residence where unit is shut down for an extended period of time, such as a vacation home, make provisions for draining condensate collection from trap and lines.

Exhaust Piping (Figures 18 and 19)

3. Route piping to outside of structure. Continue with installation following instructions given in piping termination section.



Do not discharge exhaust into an existing stack or stack that also serves another gas appliance. If vertical discharge through an existing unused stack is required, insert PVC pipe inside the stack until the end is even with the top or outlet end of the metal stack.



The exhaust vent pipe operates under positive pressure and must be completely sealed to prevent leakage of combustion products into the living space.

Removal of the Furnace from Common Vent

In the event that an existing furnace is removed from a venting system commonly run with separate gas appliances, the venting system is likely to properly vent the remaining attached appliances.

Conduct the following test while each appliance is operating and the other appliances (which are not operating) remain connected to the common venting system. If the venting system has been installed improperly, you must correct the system as indicated in the general venting requirements section.



CARBON MONOXIDE POISONING HAZARD

Failure to follow the steps outlined below for each appliance connected to the venting system being placed into operation could result in carbon monoxide poisoning or death.

Vent Piping Guidelines

This unit is installed only as a Direct Vent gas central furnace.

NOTE: *In Direct Vent installations, combustion air is taken from outdoors and flue gases are discharged outdoors.*

*Intake and exhaust pipe sizing – Size pipe according to Tables 4 and 5. Table 4 lists the **minimum** vent pipe lengths permitted. Table 5 lists the **maximum** pipe lengths permitted.*

Regardless of the diameter of pipe used, the standard roof and wall terminations described in section Exhaust Piping Terminations should be used. Exhaust vent termination pipe is sized to optimize the velocity of the exhaust gas as it exits the termination. Refer to Table 6.

In some applications which permit the use of several different sizes of vent pipe, a combination vent pipe may be used. Contact Allied Air Technical Service for more information concerning sizing of vent systems which include multiple pipe sizes.

MINIMUM VENT PIPE LENGTHS		
MODEL	MIN. EQUIV. VENT LENGTH	EXAMPLE
070, 090	15 ft.*	5ft. plus 2 elbows of 2", 2-1/2", or 3" diameter pipe
110		5 ft. plus 2 elbows of 2-1/2", 3"
135		5ft. plus 2 elbows of 3"

* Any approved termination may be added to the minimum equivalent length listed.

Table 4

NOTE: *The exhaust collar on all models is sized to accommodate 2" Schedule 40 vent pipe. In horizontal applications, transition to exhaust pipe larger than 2" must be made in vertical runs of the pipe. A 2" elbow must be added before the pipe is transitioned to any size larger than 2". This elbow must be added to the elbow count used to determine acceptable vent lengths. Contact Allied Air Technical Service for more information concerning sizing of vent systems which include multiple pipe sizes.*

NOTE: *If right side venting option is used, you must include the elbow at the furnace in the elbow count. If transitioning to 3" diameter pipe, this elbow equates to 20' of equivalent vent length for all models.*

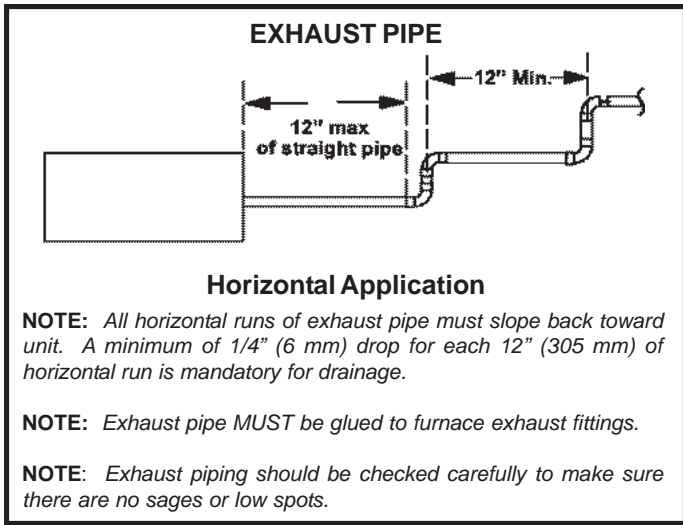

Figure 16

The following steps shall be followed for each appliance connected to the venting system being placed into operation, while all other appliances connected to the venting system are not in operation:

1. Seal any unused openings in the common venting system.
2. Inspect the venting system for proper size and horizontal pitch. Determine that there is no blockage, restriction, leakage, corrosion, or other deficiencies which could cause an unsafe condition.
3. Close all building doors and windows and all doors between the space in which the appliances remaining connected to the common venting system are located and other spaces of the building. Turn on clothes dryers and any appliances not connected to the common venting system. Turn on any exhaust fans, such as range hoods and bathroom exhausts, so they will operate at maximum speed. Do not operate a summer exhaust fan. Close fireplace dampers.
4. Follow the lighting instructions. Turn on the appliance that is being inspected. Adjust the thermostat so that the appliance operates continuously.
5. After the main burner has operated for 5 minutes, test for leaks of flue gases at the draft hood relief opening. Use the flame of a match or candle.
6. After determining that each appliance connected to the common venting system is venting properly, (step 3) return all doors, windows, exhaust fans, fireplace dampers, and any other gas furnishing appliances to their previous mode of operation.
7. If a venting problem is found during any of the preceding tests, the common venting system must be modified to correct the problem.

Resize the common venting system to the minimum vent pipe size determined by using the appropriated tables in Appendix G. (These are in the current standards of the National Fuel Gas Code ANSI Z223.1.)

Use the following steps to correctly size vent pipe diameter.

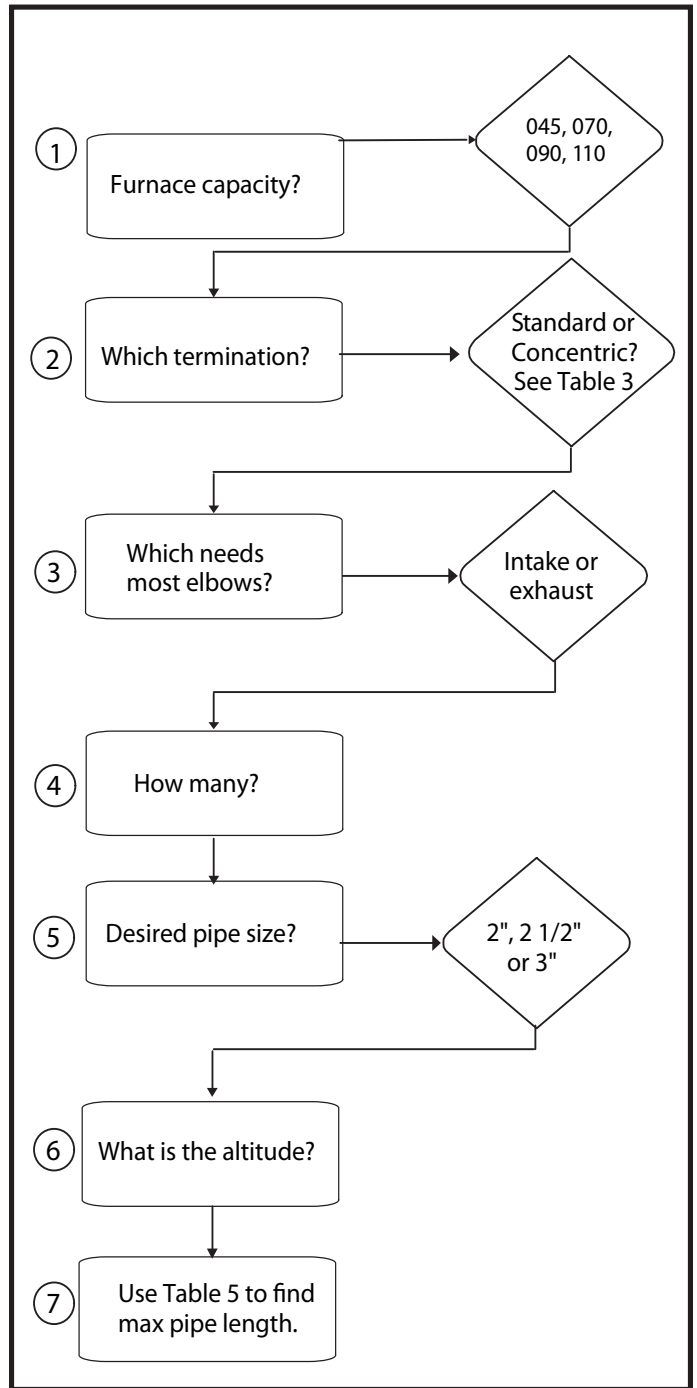

Figure 17

Maximum Allowable Intake or Exhaust Vent Length (feet)

Standard Termination at Elevation 0 - 7500 ft													
Number Of 90° Elbows Used	2" Pipe				2-1/2" Pipe				3" Pipe				
	Model				Model				Model				
	070	090	110	135	070	090	110	135	070	090	110	135	
1	86	64	n/a	n/a	135	88	38	n/a	157	138	113	109	
2	81	59			130	83	33		152	133	108	104	
3	76	54			125	78	28		147	128	103	99	
4	71	49			120	73	23		142	123	98	94	
5	66	44			115	68	18		137	118	93	89	
6	61	39			110	63	13		132	113	88	84	
7	56	34			105	58	8		127	108	83	79	
8	51	29			100	53	n/a		122	103	78	74	
9	46	24			95	48			117	98	73	69	
10	41	19			90	43			112	93	68	64	
Standard Termination Elevation 4501 - 10,000 ft													
Number Of 90° Elbows Used	2" Pipe				2-1/2" Pipe				3" Pipe				
	Model				Model				Model				
	070	090	110	135	070	090	110	135	070	090	110	135	
1	61	39	n/a	n/a	110	63	n/a	n/a	132	113	88	84	
2	56	34			105	58			127	108	83	79	
3	51	29			100	53			122	103	78	74	
4	46	24			95	48			117	98	73	69	
5	41	19			90	43			112	93	68	64	
6	36	14			85	38			n/a	107	88	63	59
7	31	9			80	33				102	83	58	54
8	26	n/a			75	28				97	78	53	49
9	21				70	23			92	73	48	44	
10	16				65	18			87	68	43	39	
Concentric Termination at Elevation 0 - 7,500 ft													
Number Of 90° Elbows Used	2" Pipe				2-1/2" Pipe				3" Pipe				
	Model				Model				Model				
	070	090	110	135	070	090	110	135	070	090	110	135	
1	78	62	n/a	n/a	125	84	34	n/a	141	134	109	100	
2	73	57			120	79	29		136	129	104	95	
3	68	52			115	74	24		131	124	99	90	
4	63	47			110	69	19		126	119	94	85	
5	58	42			105	64	14		131	114	89	80	
6	53	37			100	59	9		116	109	84	75	
7	48	32			95	54	n/a		111	104	79	70	
8	43	27			90	49			106	99	74	65	
9	38	22			85	44			101	94	69	60	
10	33	17			80	39	96		89	64	55		
Concentric Termination Elevation 4,501 - 10,000 ft													
Number Of 90° Elbows Used	2" Pipe				2-1/2" Pipe				3" Pipe				
	Model				Model				Model				
	070	090	110	135	070	090	110	135	070	090	110	135	
1	53	37	n/a	n/a	100	59	n/a	n/a	116	109	84	75	
2	48	32			95	54			111	104	79	70	
3	43	27			90	49			106	99	74	65	
4	38	22			85	44			101	94	69	60	
5	33	17			80	39			96	89	64	55	
6	28	12			75	34			n/a	91	84	59	50
7	23	7			70	29				86	79	54	45
8	18	n/a			65	24				81	74	49	40
9	13				60	19			76	69	44	35	
10	8				55	14			71	64	39	30	

Table 5

**TYPICAL EXHAUST PIPE CONNECTIONS AND CONDENSATE TRAP INSTALLATION
IN UPFLOW APPLICATIONS**

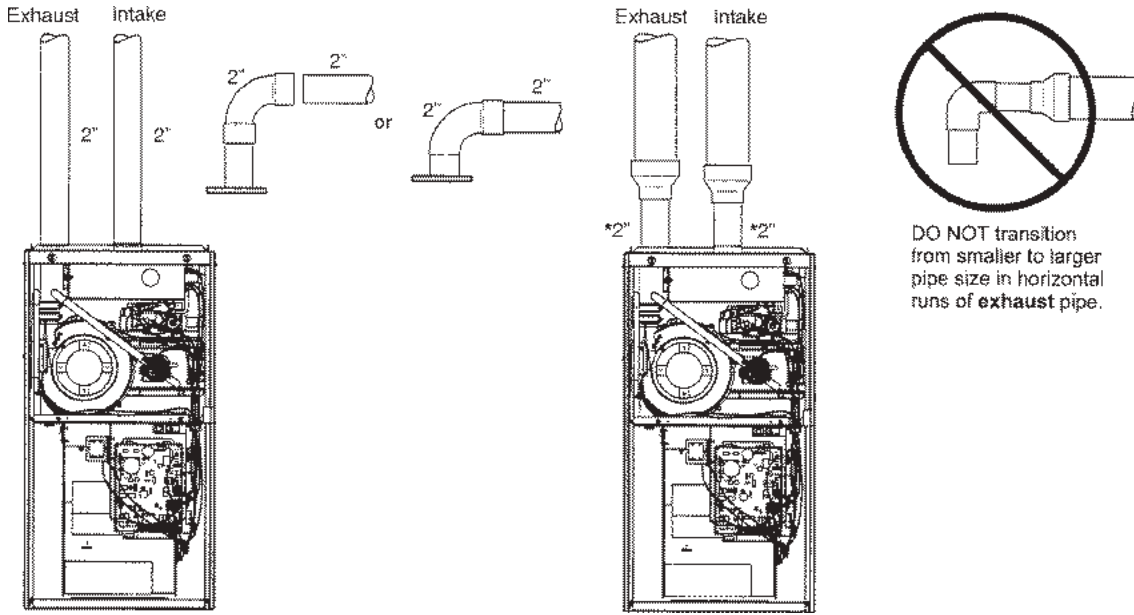

Figure 18

**TYPICAL EXHAUST PIPE CONNECTIONS AND CONDENSATE TRAP INSTALLATION
IN HORIZONTAL AIR APPLICATIONS
(RIGHT HAND DISCHARGE SHOWN)**

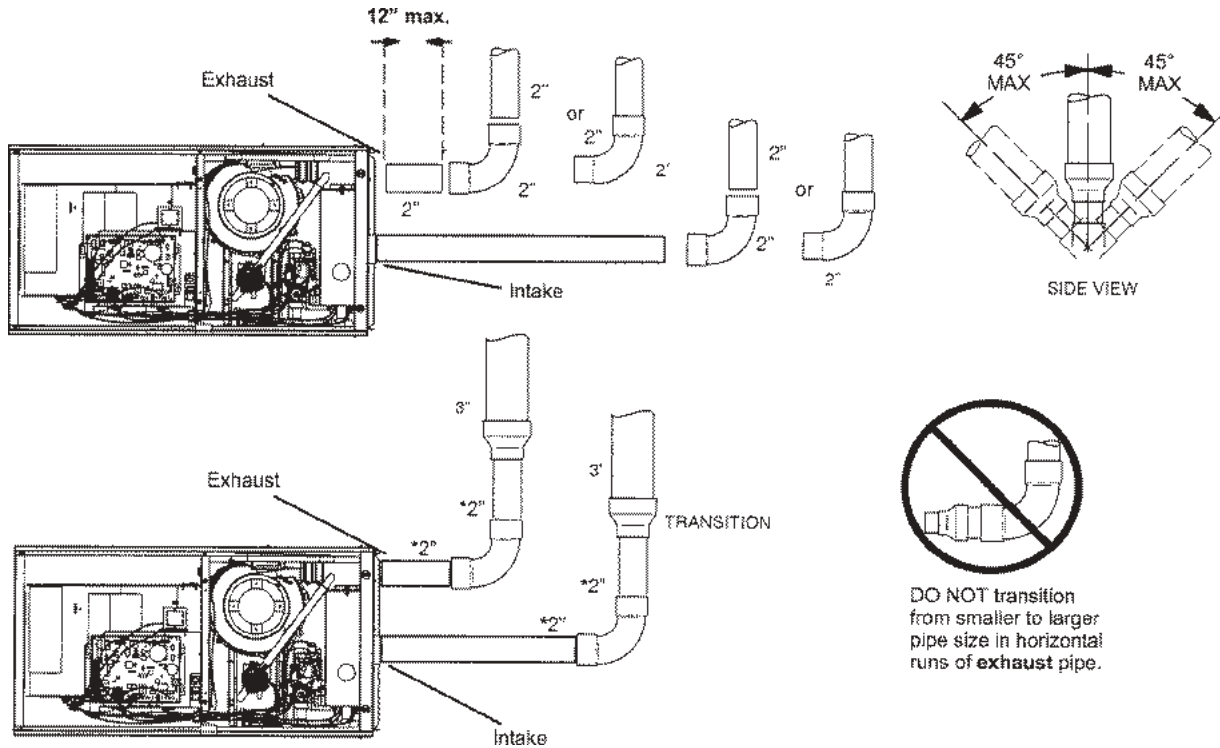
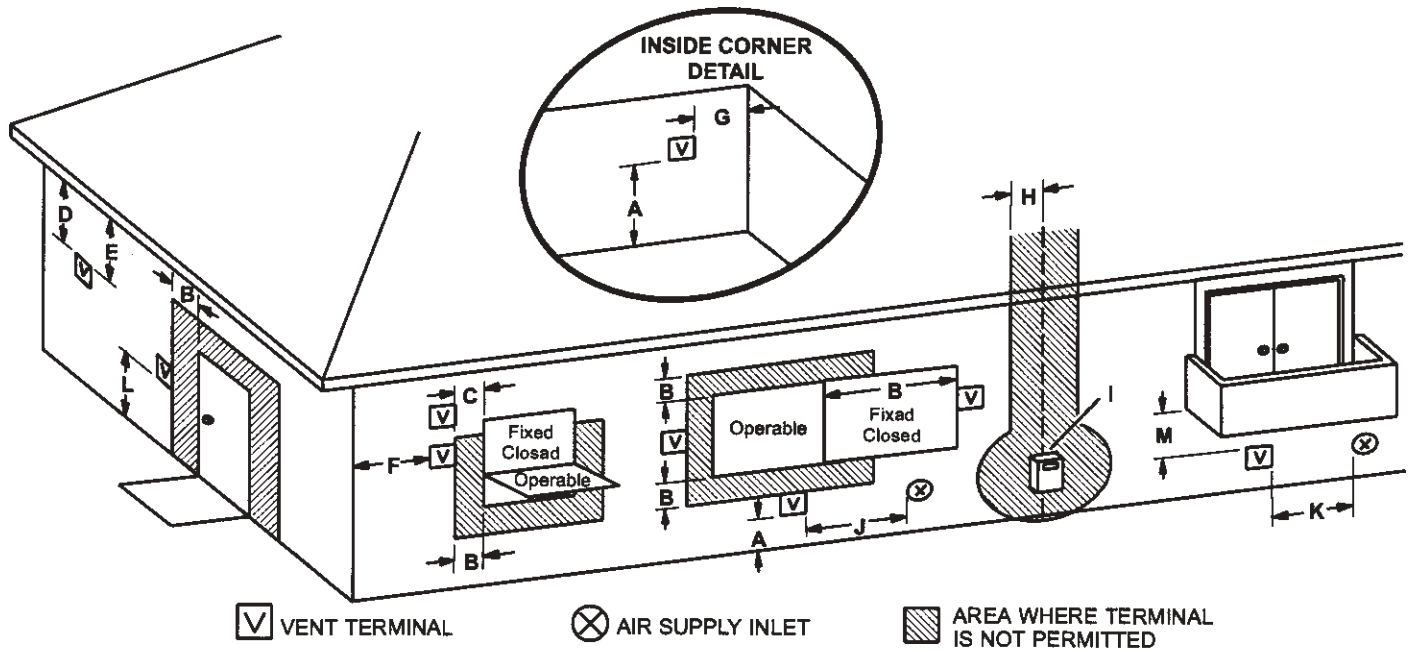

Figure 19

VENT TERMINATION CLEARANCES FOR DIRECT VENT INSTALLATIONS IN THE USA AND CANADA



	US Installations ¹	Canadian Installations ²	
A =	Clearance above grade, veranda, porch, deck or balcony	12 inches (305mm) or 12 in. 305mm above average snow accumulation.	12 inches (305mm) or 12 in. 305mm above average snow accumulation.
B =	Clearance to window or door that may be opened	6 inches (152mm) for appliances <10,000 Btuh (3kw), 9 inches (mm) for appliances > 10,000 Btuh (3kw) and <50,000 Btuh (15 kw), 12 inches (305mm) for appliances > 50,000 Btuh (15kw)	6 inches (152mm) for appliances <10,000 Btuh (3kw), 12 inches (305mm) for appliances > 10,000 Btuh (3kw) and <100,000 Btuh (30kw), 36 inches (.9m) for appliances > 100,000 Btuh (30kw)
C =	Clearance to permanently closed window	* 12"	* 12"
D =	Vertical clearance to ventilated soffit located above the terminal within a horizontal distance of 2 feet (mm) from the center line of the terminal	* Equal to or greater than soffit depth	* Equal to or greater than soffit depth
E =	Clearance to unventilated soffit	* Equal to or greater than soffit depth	* Equal to or greater than soffit depth
F =	Clearance to outside corner	* No minimum to outside corner	* No minimum to outside corner
G =	Clearance to inside corner	* 3 feet (.9m)	* 3 feet (.9m)
H =	Clearance to each side of center line extended above meter / regulator assembly	3 feet (.9m) within a height 15 feet (4.5m) above the meter / regulator assembly	3 feet (.9m) within a height 15 feet (4.5m) above the meter / regulator assembly
I =	Clearance to service regulator vent outlet	* 3 feet (.9m)	3 feet (.9m)
J =	Clearance to non-mechanical air supply inlet to building or the combustion air inlet to any other appliance	6 inches (152mm) for appliances <10,000 Btuh (3kw), 9 inches (mm) for appliances > 10,000 Btuh (3kw) and <50,000 Btuh (15 kw), 12 inches (305mm) for appliances > 50,000 Btuh (15kw)	6 inches (152mm) for appliances <10,000 Btuh (3kw), 12 inches (305mm) for appliances > 10,000 Btuh (3kw) and <100,000 Btuh (30kw), 36 inches (.9m) for appliances > 100,000 Btuh (30kw)
K =	Clearance to mechanical air supply inlet	3 feet (.9m) above if within 10 feet (3m) horizontally	6 feet (1.8m)
L =	Clearance above paved sidewalk or paved driveway located on public property	* 7 feet (2.1m)	7 feet (2.1m)†
M =	Clearance under veranda, porch, deck or balcony	*12 inches (305mm)‡	12 inches (305mm)‡

¹ In accordance with the current ANSI Z223.1/NFPA 54 Natural Fuel Gas Code

² In accordance with the current CSA B149.1, Natural Gas and Propane Installation Code

† A vent shall not terminate directly above a sidewalk or paved driveway that is located between two single family dwellings and serves both dwellings.

‡ Permitted only if veranda, porch, deck or balcony is fully open on a minimum of two sides beneath the floor. Allied Air recommends avoiding this location if possible.

For clearances not specified in ANSI Z223.1/NFPA 54 or CSA B149.1, clearance will be in accordance with local installation codes and the requirements of the gas supplier and these installation instructions.

Figure 20

General Guidelines for Vent Terminations

In Direct Vent applications, combustion air is taken from outdoors and the flue gases are discharged to the outdoors. This gas furnace is classified as a direct vent, Category IV gas furnace.

In Direct Vent applications, the vent termination is limited by local building codes. In the absence of local codes, refer to the current National Fuel Gas Code ANSI Z223-1/NFPA 54 in U.S.A., and current CSA-B149 Natural Gas and Propane Installation Codes in Canada for details.

Position termination according to location given in Figure 20. In addition, position termination so it is free from any obstructions and 12" above the average snow accumulation.

At vent termination, care must be taken to maintain protective coatings over building materials (prolonged exposure to exhaust condensate can destroy protective coatings). It is recommended that the exhaust outlet not be located within 6 feet (1.8m) of a condensing unit because the condensate can damage the painted coating.

NOTE: See Table 6 for maximum allowed exhaust pipe length without insulation in unconditioned space during

winter design temperatures below 32°F (0°C). If required exhaust pipe should be insulated with 1/2" (13mm) Armaflex or equivalent. In extreme cold climate areas, 3/4" (19mm) Armaflex or equivalent may be necessary. Insulation on outside runs of exhaust pipe must be painted or wrapped to protect insulation from deterioration. Exhaust pipe insulation may not be necessary in some specific applications.

! IMPORTANT

Do not use screens or perforated metal in exhaust terminations. Doing so will cause freeze-ups and may block the terminations.

! IMPORTANT

FOR CANADIAN INSTALLATIONS ONLY:

In accordance to CSA International B149 installation codes, the minimum allowed distance between the combustion air intake inlet and the exhaust outlet of other appliances shall not be less than 12 inches (305 mm).

Maximum Allowable Vent pipe Length without Insulation in Unconditioned Space for Winter Design Temperatures Modulating High Efficiency Furnace

Winter Design Temperatures ¹ °F (°C)	Vent Pipe Diameter	Unit Input Size			
		070	090	110	135
32 to 21 (0 to -6)	2 in.	8	14	14	n/a
	2-1/2 in.	6	9	12	n/a
	3 in.	4	6	8	12
20 to 1 (-7 to -17)	2 in.	5	7	8	n/a
	2-1/2 in.	4	5	6	n/a
	3 in.	2	2	4	6
0 to -20 (-18 to -29)	2 in.	3	4	5	n/a
	2-1/2 in.	2	2	3	n/a
	3 in.	1	1	1	2

¹Refer to 99% Minimum Design Temperature table provided in the current edition of the ASHRAE Fundamentals Handbook.
NOTE: Maximum uninsulated vent lengths listed cannot exceed the maximum allowable intake or exhaust vent length listed in Table 5.

Table 6

Details of Intake and Exhaust Piping Terminations for Direct Vent Installations

NOTE: In Direct Vent installations, combustion air is taken from outdoors and flue gases are discharged to outdoors.

Intake and exhaust pipes may be routed either horizontally through and outside wall or vertically through the roof. In attic or closet installations, vertical termination through the roof is preferred. Figures 23 through 29 show typical terminations.

1. Intake and exhaust terminations are not required to be in the same pressure zone. You may exit the intake on one side of the structure and the exhaust on another side (Figure). You may exit the exhaust out the roof and the intake out the side of the structure (Figure).
2. Intake and exhaust pipes should be placed as close together as possible at termination end (refer to illustrations). Maximum separation is 3" (76 mm) on roof terminations and 6" (152 mm) on sidewall terminations.
3. On roof terminations, the intake piping should terminate straight down using two 90° elbows (See Figure 21).
4. Exhaust piping must terminate straight out or up as shown. A reducer is required on the exhaust piping at the point where it exits the structure to improve the velocity of exhaust away from the intake piping. See Table 6.

NOTE: Care must be taken to avoid recirculation of exhaust back into intake pipe.

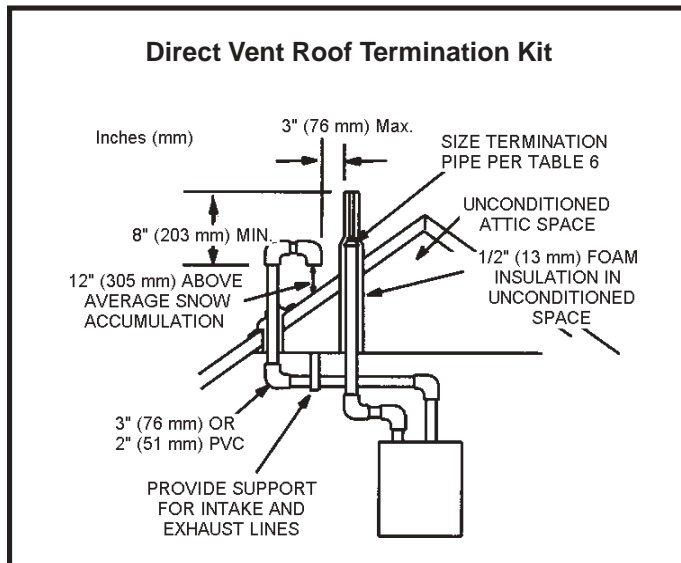

Figure 21

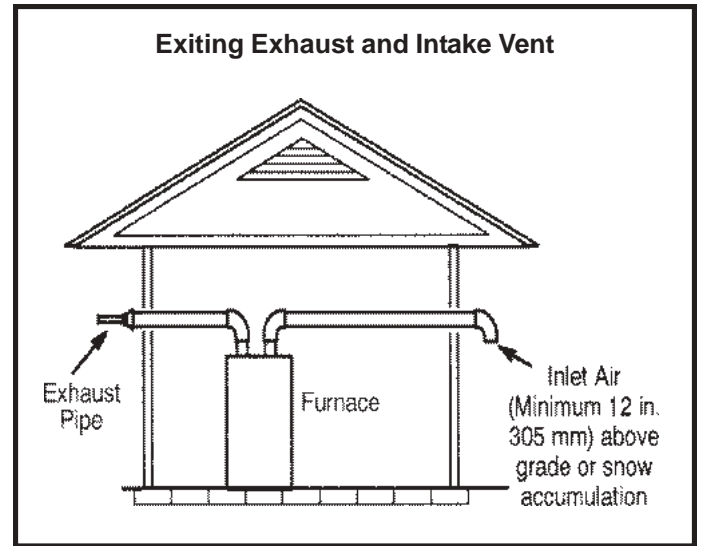

Figure 22

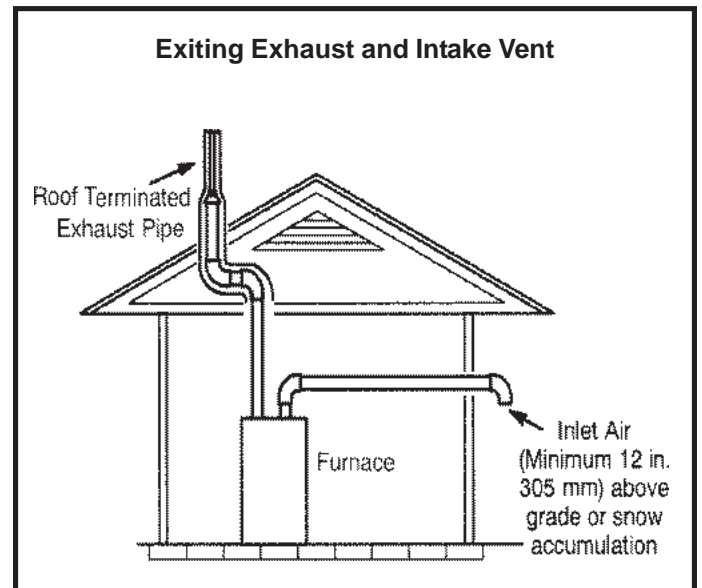

Figure 23

Field Supplied Wall Termination or (15F74) Wall Ring Termination Kit

NOTE: FIELD PROVIDED REDUCER MAY BE REQUIRED TO ADAPT LARGER VENT PIPE SIZE TO TERMINATION

1/2" (13 mm) ARMAFLEX INSULATION IN UNCONDITIONED SPACE

SIZE TERMINATION PER TABLE 6

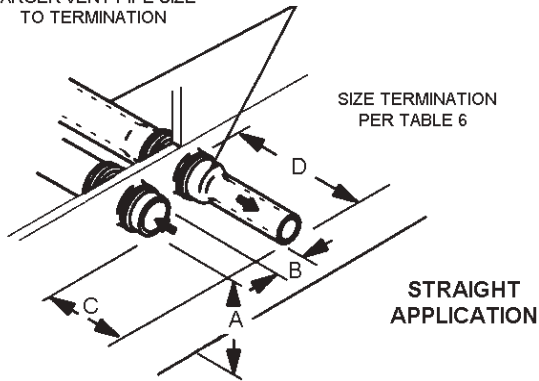

STRAIGHT APPLICATION

1/2" (13 mm) ARMAFLEX INSULATION IN UNCONDITIONED SPACE

* WALL SUPPORT

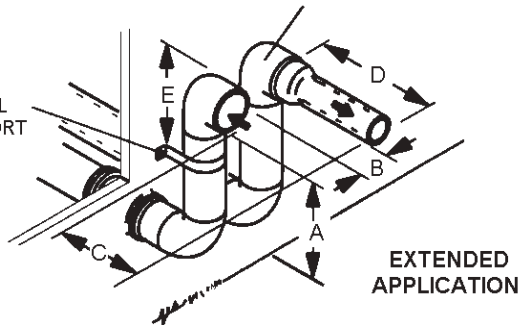

EXTENDED APPLICATION

See venting Table 5 for maximum venting lengths with this arrangement.

* Use wall support every 24" (610 mm). Use two wall supports if extension is greater than 24" (610 mm) but less than 48" (1219 mm).

NOTE: One wall support must be 6" (152 mm) from top of each pipe (intake and exhaust).

	2" (51 mm) Vent Pipe	3" (76 mm) Vent Pipe
A-Minimum clearance above grade or average snow accumulation	12" (305 mm)	12" (305 mm)
B-Maximum horizontal separation between intake and exhaust	6" (152 mm)	6" (152 mm)
C-Minimum from end of exhaust to inlet of intake	8" (203 mm)	8" (203 mm)
D-Maximum exhaust pipe length	12" (305 mm)	20" (508 mm)
E-Maximum wall support distance from top of each pipe (intake/exhaust)	6" (152 mm)	6" (152 mm)

Figure 24

Field Supplied Wall Termination with Intake Elbow

NOTE: FIELD PROVIDED REDUCER MAY BE REQUIRED TO ADAPT LARGER VENT PIPE SIZE TO TERMINATION

1/2" (13 mm) ARMAFLEX INSULATION IN UNCONDITIONED SPACE

SIZE TERMINATION PER TABLE 6

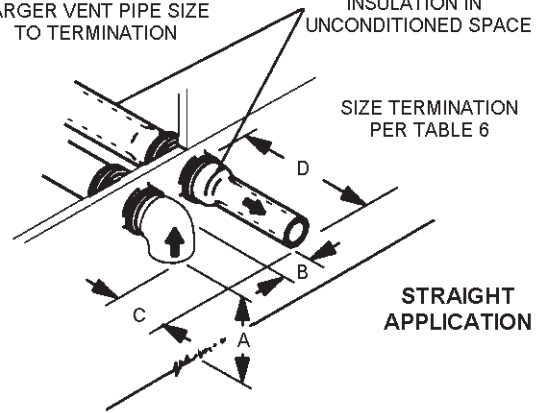

STRAIGHT APPLICATION

1/2" (13 mm) ARMAFLEX INSULATION IN UNCONDITIONED SPACE

* WALL SUPPORT

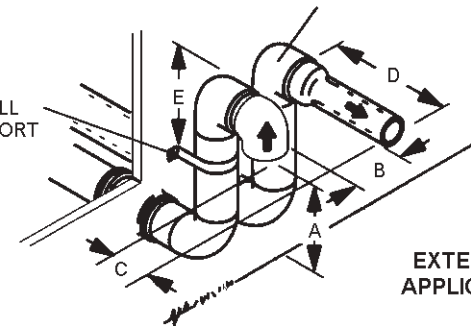

EXTENDED APPLICATION

See venting Table 5 for maximum venting lengths with this arrangement.

* Use wall support every 24" (610 mm). Use two wall supports if extension is greater than 24" (610 mm) but less than 48" (1219 mm).

NOTE: One wall support must be 6" (152 mm) from top of each pipe (intake and exhaust).

	2" (51 mm) Vent Pipe	3" (76 mm) Vent Pipe
A-Minimum clearance above grade or average snow accumulation	12" (305 mm)	12" (305 mm)
B-Maximum horizontal separation between intake and exhaust	6" (152 mm)	6" (152 mm)
C-Minimum from end of exhaust to inlet of intake	6" (152 mm)	6" (152 mm)
D-Maximum exhaust pipe length	12" (305 mm)	20" (508 mm)
E-Maximum wall support distance from top of each pipe (intake/exhaust)	6" (152 mm)	6" (152 mm)

Figure 25

Exhaust Pipe Termination Size Reduction

MODEL	Exhaust Pipe Size	Termination Pipe Size
070 *	2", 2-1/2" or 3"	1-1/2"
090 *	2", 2-1/2" or 3"	2"
110	2-1/2" or 3"	2"
135	3"	2"

* 070 and 090 units installed with flush mount termination must use the 1-1/2" accelerator supplied with the kit.

Table 7

- On field supplied terminations for sidewall exit, exhaust piping may extend a maximum of 12 inches (305 mm) for 2" PVC and 20 inches (508 mm) for 3" (76 mm) PVC beyond the outside wall. Intake piping should be as short as possible. See Figures 22 and 23.
- On field supplied terminations, a minimum distance between the end of the exhaust pipe and the end of the intake pipe without a termination elbow is 8" and a minimum distance of 6" with a termination elbow. See Figures 22 and 23.
- If intake and exhaust piping must be run up a side wall to position above snow accumulation or other obstructions, piping must be supported every 24" (610 mm) as shown in Figures 22 and 23. In addition, close coupled wall termination must be extended for use in this application. See Figures 22 and 23. When exhaust and intake piping must be run up an with pipe sized per Table 7. The intake piping may be equipped with a 90° elbow turndown. Using turndown will add 5 feet (1.5 m) to the equivalent length of the pipe.

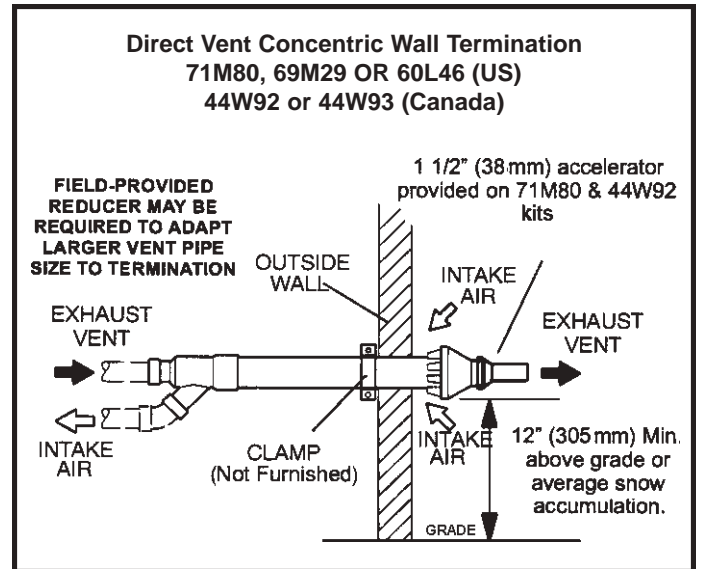

Figure 27

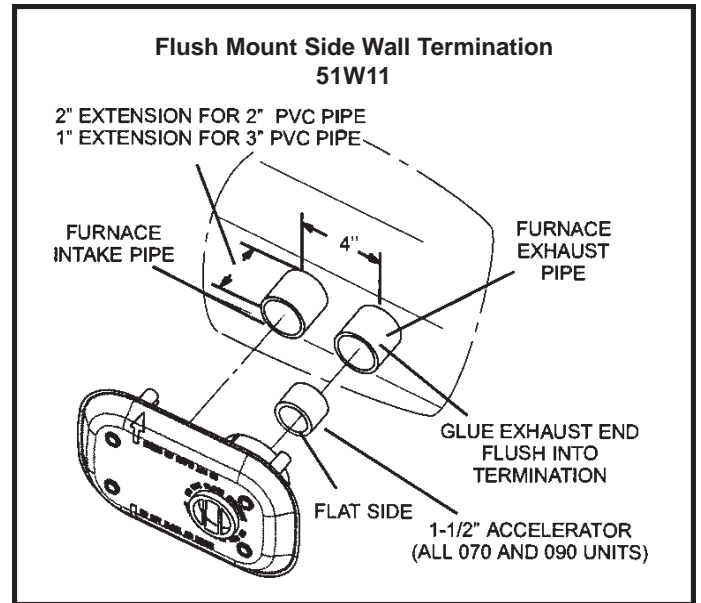

Figure 28

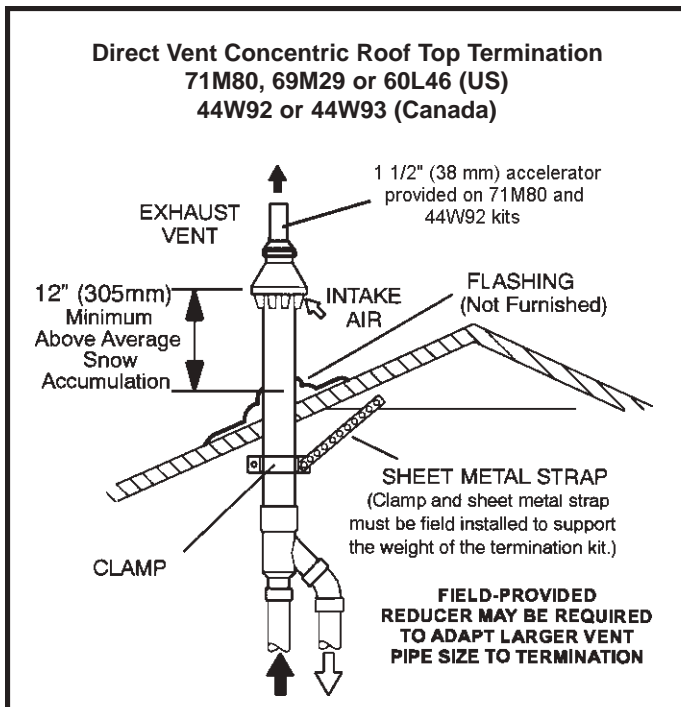

Figure 26

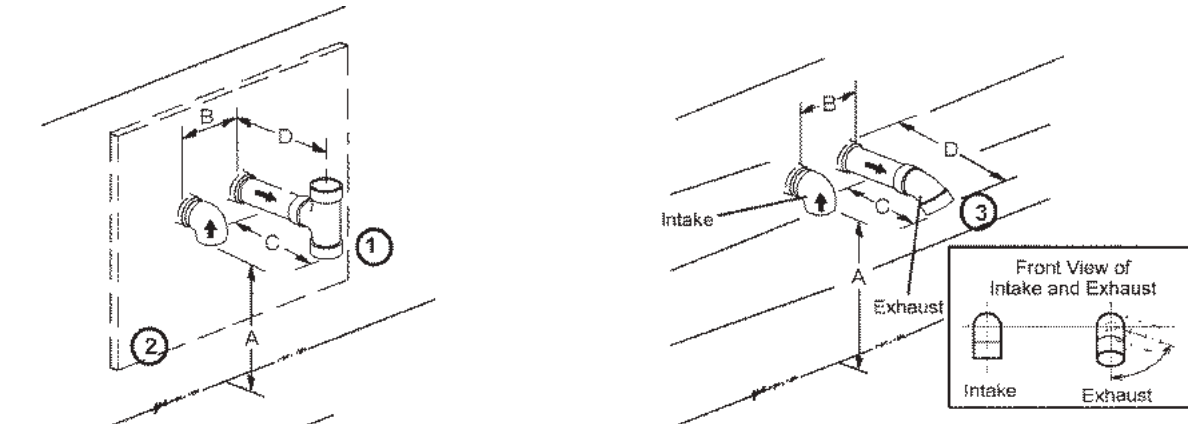

TABLE 8

	2" (51mm) Vent Pipe	3" (76mm) Vent Pipe
A- Clearance above grade or average snow accumulation	12" (305MM) Min.	12" (305MM) Min.
B- Horizontal separation between intake and exhaust	6" (152MM) Min. 24" (610 MM) Max	6" (152MM) Min. 24" (610 MM) Max
C- Minimum from end of exhaust to inlet of intake	9" (227MM) Min.	9" (227MM) Min.
D- Exhaust pipe length	12" (305MM) Min. 16" (405 MM) Max.	12" (305MM) Min. 20" (508MM) Max.
E- Wall support distance from top of each pipe (intake/exhaust)	6" (152MM) Max.	6" (152MM) Max.

NOTE - See unit installation instructions for proper exhaust pipe termination size reduction.

- ¹ The exhaust termination tee should be connected to the 2" or 3" PVC flue pipe as shown in the illustration. Do not use an accelerator in applications that include an exhaust termination tee. The accelerator is not required.
- ² As required. Flue gas may be acidic and may adversely affect some building materials. If a side wall vent termination is used and flue gases will impinge on the building materials, a corrosion-resistant shield (24 inches square) should be used to protect the wall surface. If optional tee is used, the protective shield is recommended. The shield should be constructed using wood, sheet metal or other suitable material. All seams, joints, cracks, etc. in affected area, should be sealed using an appropriate sealant.
- ³ Exhaust pipe 45° elbow can be rotated to the side away from the combustion air inlet to direct exhaust away from adjacent property. The exhaust must never be directed toward the combustion air inlet.

Figure 29

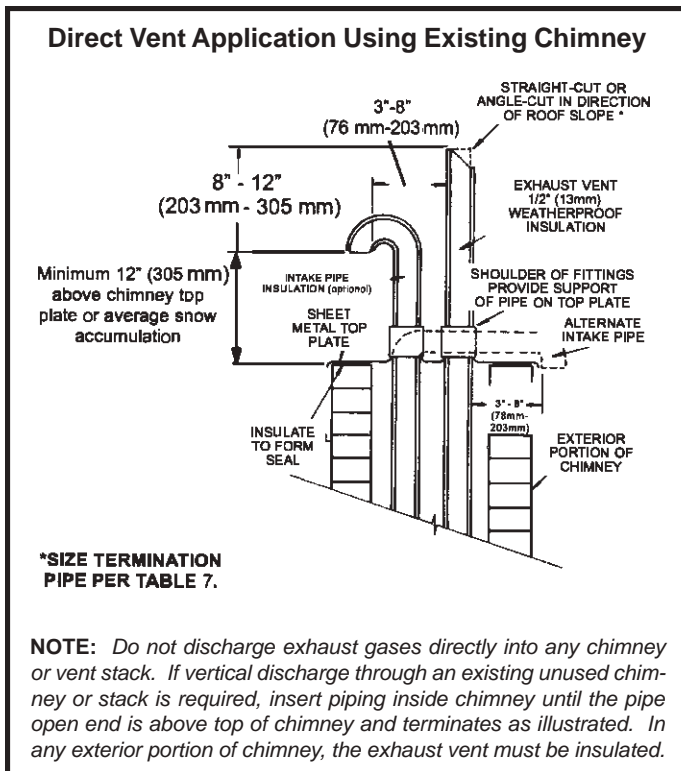

Figure 30

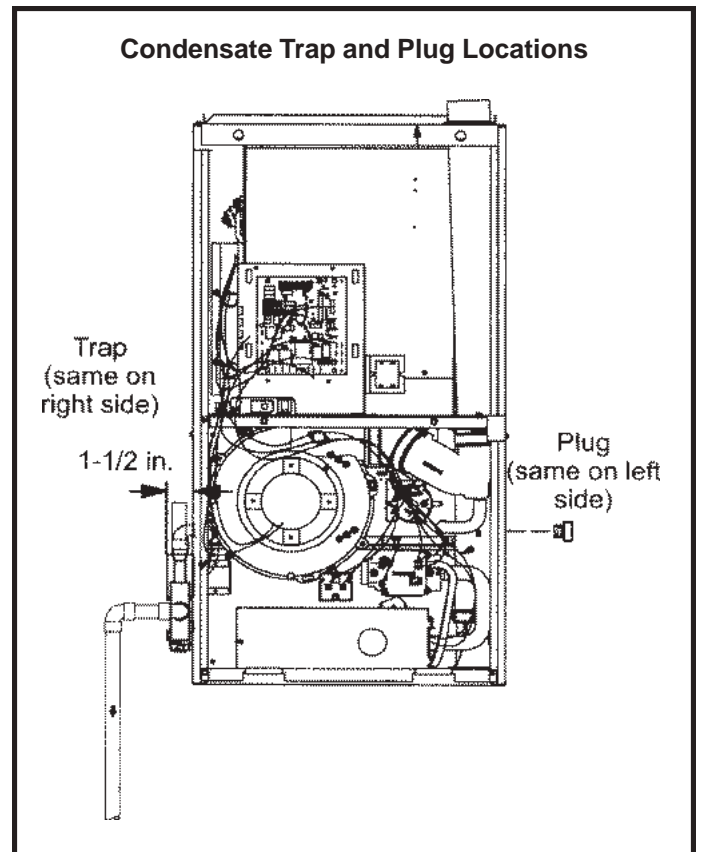

Figure 31

Condensate Piping

This unit is designed for either right or left side exit of condensate piping. Refer to Figure 31 for condensate trap locations.

NOTE: If necessary the condensate trap may be installed up to 5 ft. away, using PVC pipe, from the furnace. Piping from furnace must slope down a minimum of 1/4" per ft. toward trap.

1. Determine which side condensate piping will exit the unit, location of trap, field-provided fittings and length of PVC pipe required to reach available drain.
2. Use a large flat head screw driver or a 1/2" drive socket extension and remove plug (Figure 31) from the cold end header box at the appropriate location on the side of the unit. Install provided 3/4 NPT street elbow fitting into cold end header box. Use Teflon tape or appropriate pipe dope.
3. Install the cap over the clean out opening at the base of the trap. Secure with clamp. See Figure 36.

4. Install drain trap using appropriate PVC fittings, glue all joints. Glue the provided drain trap as shown in Figure 36. Route the condensate line to an open drain.
5. Figure 34 shows the furnace and evaporator coil using a separate drain. If necessary the condensate line from the furnace and evaporator coil can drain together. See Figure 35. The field provided vent must be minimum 1" to a maximum 2" length above the condensate drain outlet connection.
6. If unit will be started immediately upon completion of installation, prime trap per procedure outlined in **Unit Start-Up** section.

NOTE: Vinyl tubing may be used for condensate drain. Tubing must be 1-1/4" OD X 1" ID and should be attached to the drain on the trap using a hose clamp.

Condensate line must slope downward away from the trap to drain. If drain level is above condensate trap, condensate pump must be used. Condensate drain line should be routed within the conditioned space to avoid freezing of condensate and blockage of drain line. If this is not possible, a heat cable kit may be used on the condensate trap and line. Heat cable kit is available in various lengths: 6 ft. (1.8 m) - Kit No. 26K68; 24 ft. (7.3 m) - Kit No. 26K69; and 50 ft. (15.2 m) - Kit No. 26K70.

! IMPORTANT

When combining the furnace and evaporator coil drains together, the A/C condensate drain outlet must be vented to relieve pressure in order for the furnace pressure switch to operate properly.

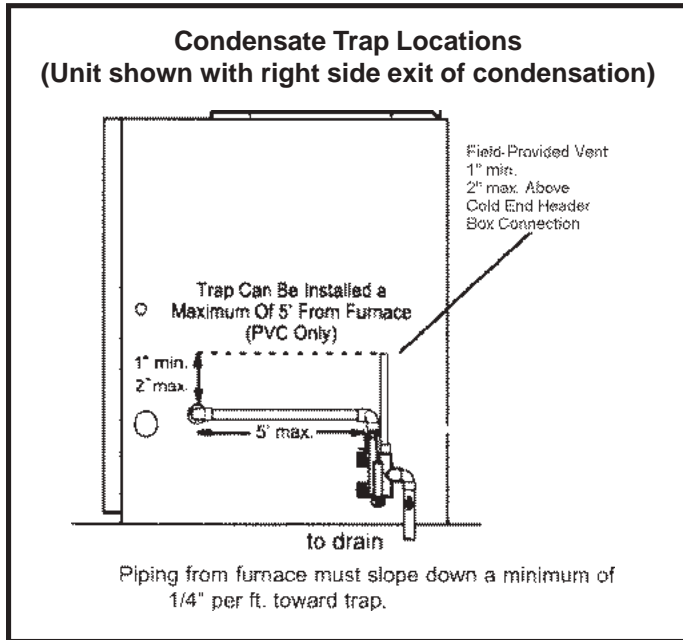

Figure 32

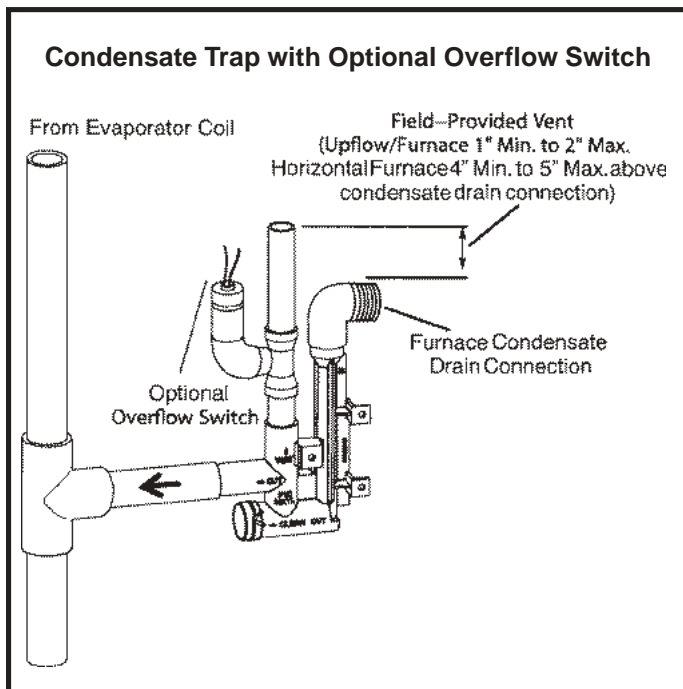

Figure 33

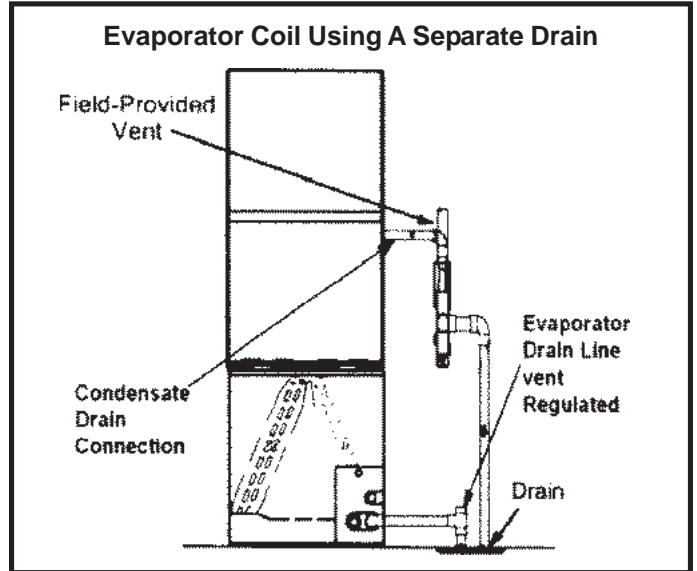

Figure 34

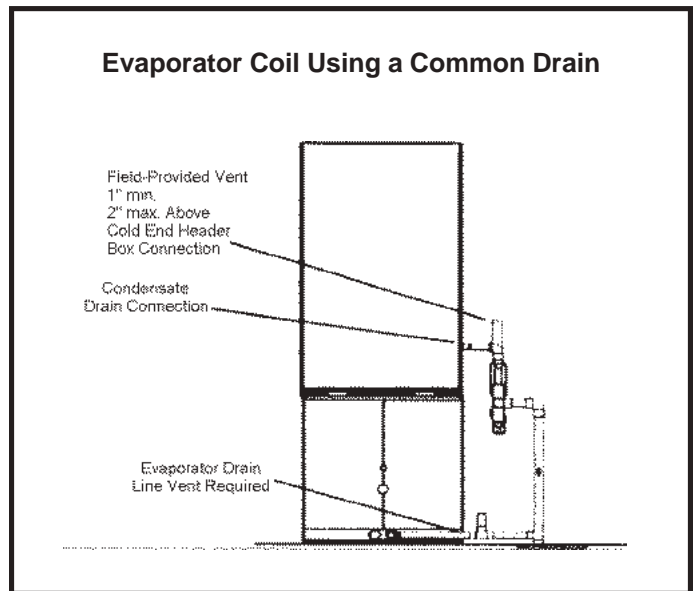

Figure 35

! CAUTION

Do not use copper tubing or existing copper condensate lines for drain line.

Trap / Drain Assembly Using 1/2" PVC or 3/4" PVC

Optional Condensate Drain Connection

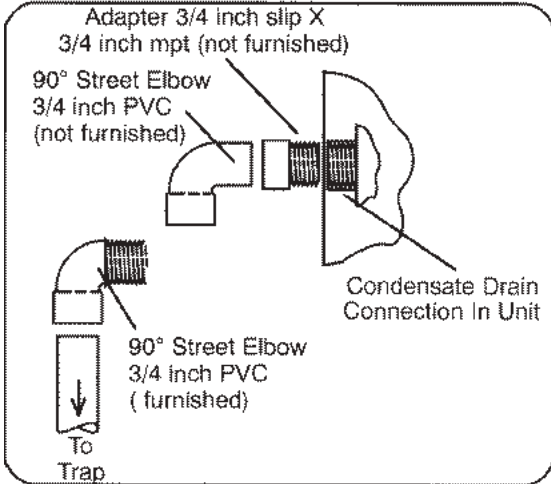

Optional Drain Piping From Trap

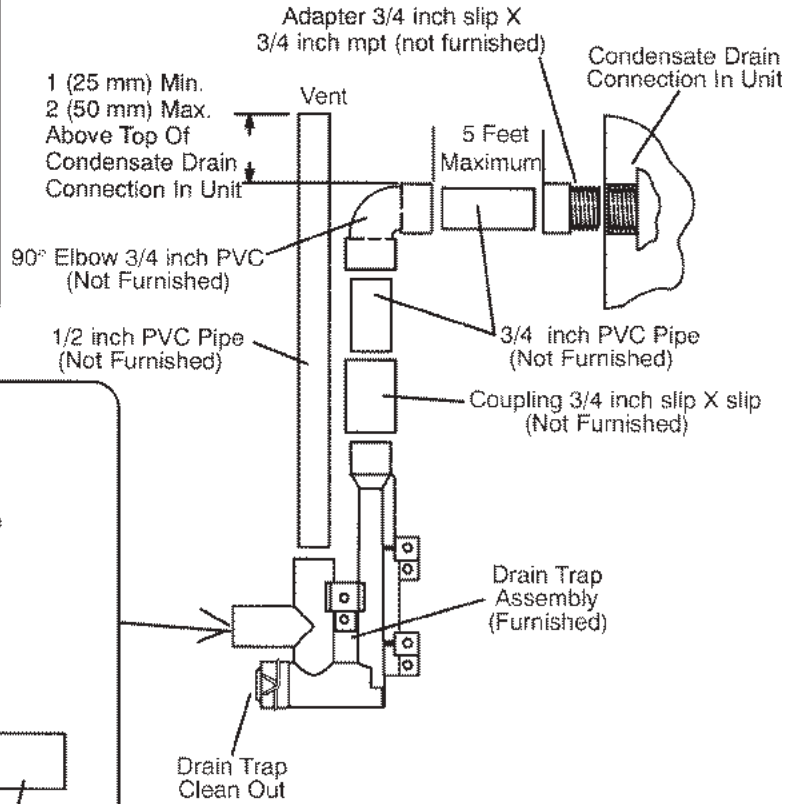
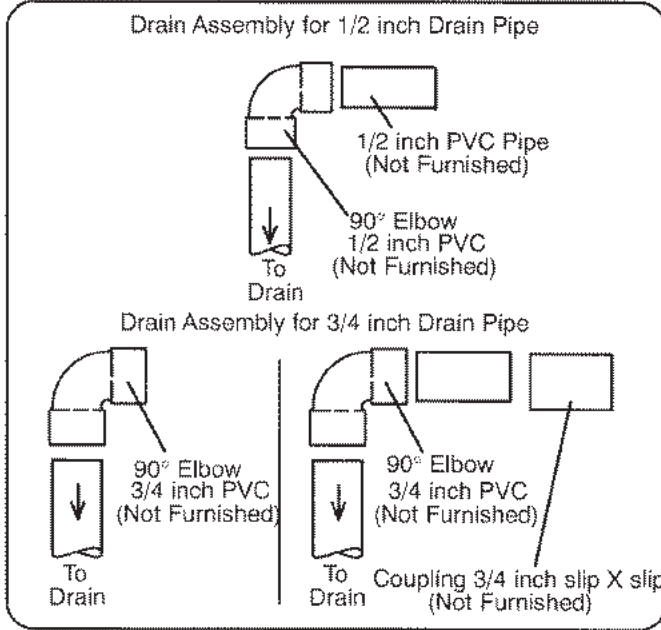

Drain Trap Assembly with 1/2 inch Piping

1 (25 mm) Min. 2 (50 mm) Max. Above Top Of Condensate Drain Connection In Unit

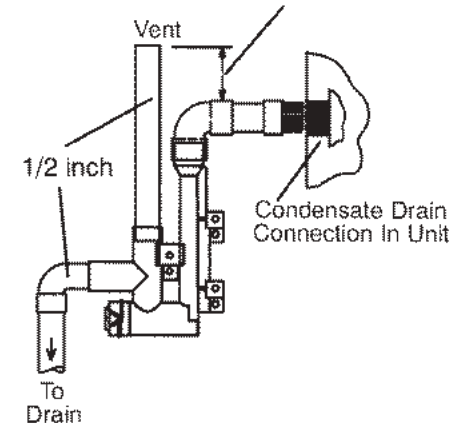

Drain Trap Assembly with 3/4 inch Piping

1 (25 mm) Min. 2 (50 mm) Max. Above Top Of Condensate Drain Connection In Unit

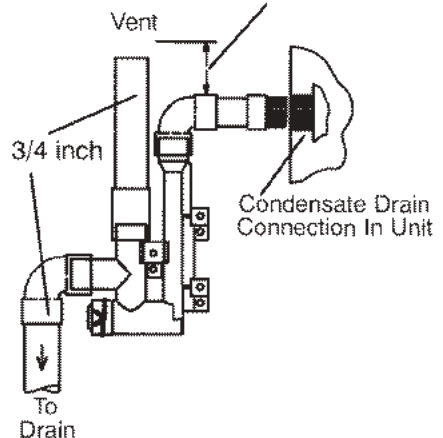

Drain Trap Assembly (Furnished)

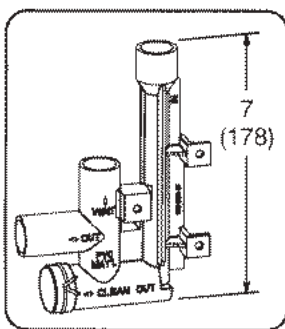

Figure 36

Gas Piping

CAUTION

If a flexible gas connector is required or allowed by the authority that has jurisdiction, black iron pipe shall be installed at the gas valve and extend outside of the furnace cabinet.

WARNING

Do not exceed 600 in. lbs. (50 ft. lbs.) torque when attaching the gas piping to the gas valve.

1. Gas piping may be routed into the unit through either the left or right hand side. Supply piping enters into the gas valve from the side of the valve as shown in Figure 39.
2. When connecting gas supply, factors such as length of run, number of fittings and furnace rating must be considered to avoid excessive pressure drop. Table 9 lists recommended pipe sizes for typical applications.

NOTE: Use two wrenches when connecting gas piping to avoid transferring torque to the manifold.

3. Gas piping must not run in or through air ducts, clothes chutes, chimneys or gas vents, dumb waiters or elevator shafts. Center gas line through piping hole. Gas line should not touch side of unit. See Figure 39.
4. Piping should be sloped 1/4 inch per 15 feet (6 mm per 5.6 m) upward toward the gas meter from the furnace. The piping must be supported at proper intervals, every 8 to 10 feet (2.44 to 3.05 m), using suitable hangers or straps. Install a drip leg in vertical pipe runs to serve as a trap for sediment or condensate.
5. A 1/8" NPT plugged tap or pressure post is located on the gas valve to facilitate test gauge connection. See Figure 47.
6. In some localities, codes may require installation of a manual main shut off valve and union (furnished by installer) external to the unit. Union must be of the ground joint type.

IMPORTANT

Compounds used on threaded joints of gas piping must be resistant to the actions of liquified petroleum gases.

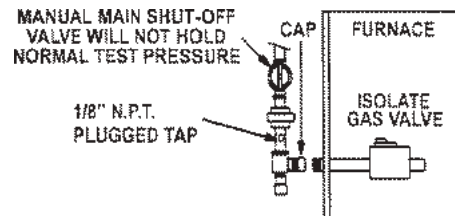

Figure 37

Leak Check

After gas piping is completed, carefully check all piping connections (factory and field installed) for gas leaks. Use a leak detecting solution or other preferred means.

The furnace must be isolated from the gas supply system by closing its individual manual shut off valve during any pressure testing of the gas supply system at pressures less than or equal to 1/2 psig (3.48 kPa, 14 inches w.c.).

CAUTION

When testing gas lines using pressures in excess of 1/2 psig (3.48 kPa), gas valve must be disconnected and isolated. See Figure 38. Gas valves can be damaged if subjected to pressures greater than 1/2 psig (3.48 kPa).

WARNING

FIRE OR EXPLOSION HAZARD

Failure to follow the safety warnings exactly could result in serious injury, death, or property damage. Never use an open flame to test for gas leaks. Check all connections using a commercially available soap solution made specifically for leak detection. Some soaps used for leak detection are corrosive to certain metals. Carefully rinse piping thoroughly after leak test has been completed.

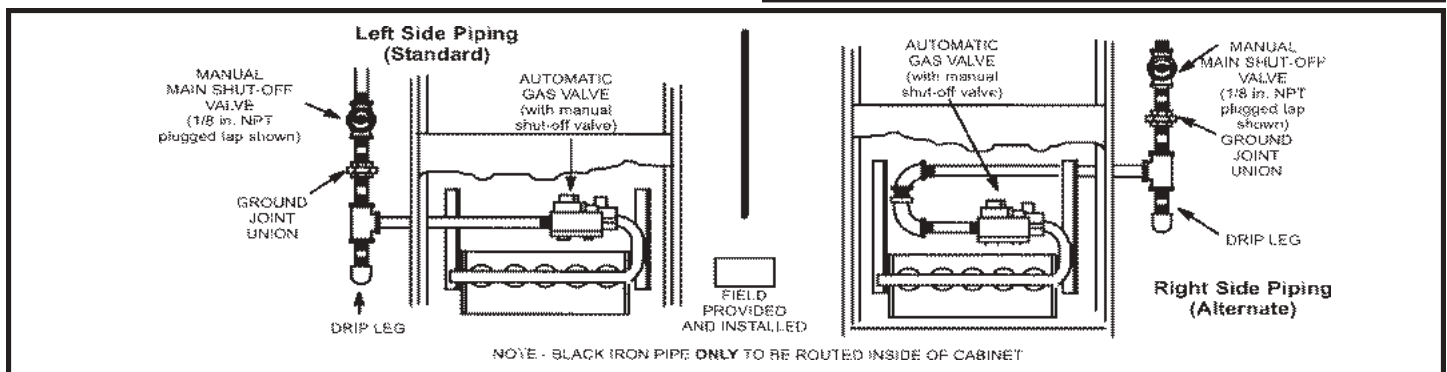

Figure 38

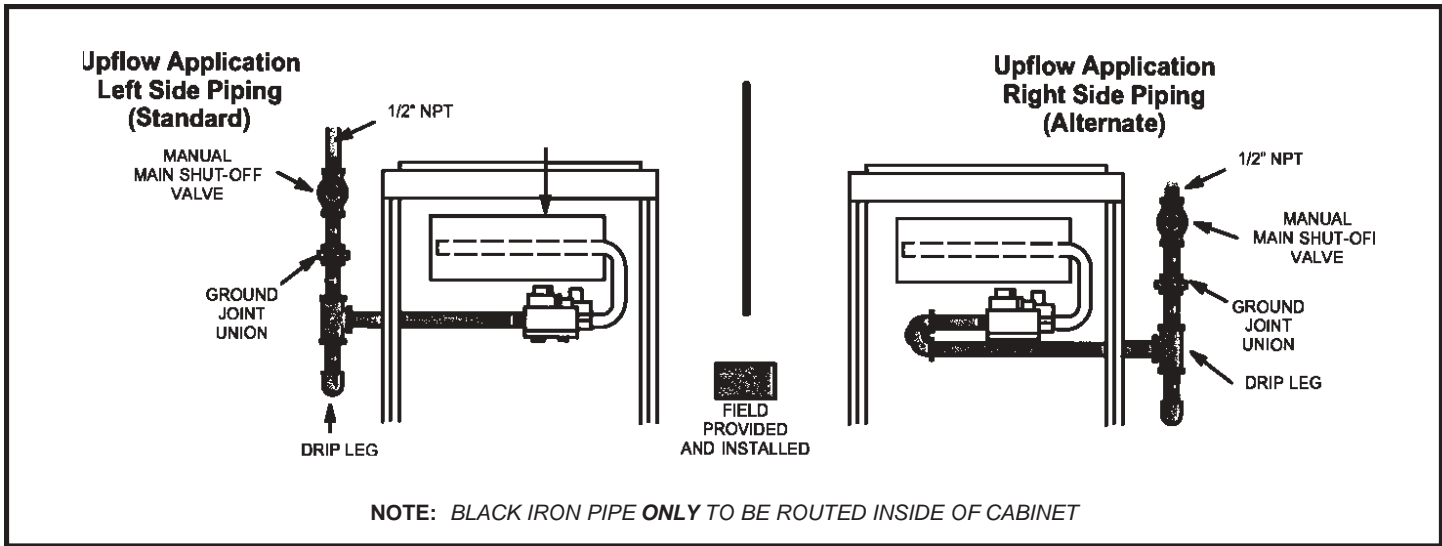

Figure 36

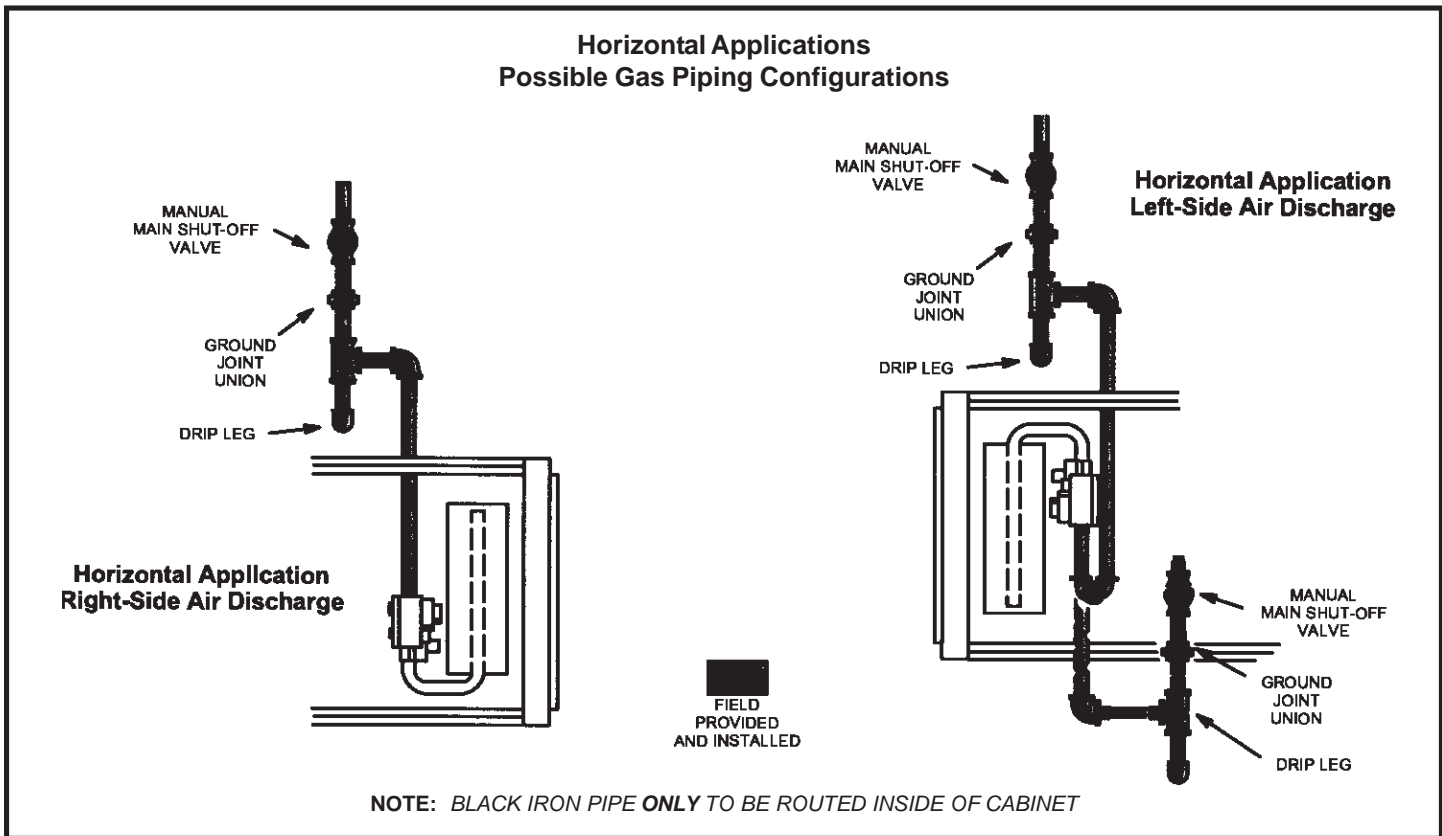

Figure 37

GAS PIPE CAPACITY - FT³/HR (KL/HR)

Nominal Iron Pipe Size Inches(mm)	Internal Diameter Inches(mm)	Length of Pipe—Feet(m)									
		10 (3.048)	20 (6.096)	30 (9.144)	40 (12.192)	50 (15.240)	60 (18.288)	70 (21.336)	80 (24.384)	90 (27.432)	100 (30.480)
1/2 (12.7)	.622 (17.799)	175 (4.96)	120 (3.40)	97 (2.75)	82 (2.32)	73 (2.07)	66 (1.87)	61 (1.73)	57 (1.61)	53 (1.50)	50 (1.42)
3/4 (19.05)	.824 (20.930)	360 (10.19)	250 (7.08)	200 (5.66)	170 (4.81)	151 (4.28)	138 (3.91)	125 (3.54)	118 (3.34)	110 (3.11)	103 (2.92)
1 (25.4)	1.049 (26.645)	680 (19.25)	465 (13.17)	375 (10.62)	320 (9.06)	285 (8.07)	260 (7.36)	240 (6.80)	220 (6.23)	205 (5.80)	195 (5.52)
1-1/4 (31.75)	1.380 (35.052)	1400 (39.64)	950 (26.90)	770 (21.80)	660 (18.69)	580 (16.42)	530 (15.01)	490 (13.87)	460 (13.03)	430 (12.18)	400 (11.33)
1-1/2 (38.1)	1.610 (40.894)	2100 (59.46)	1460 (41.34)	1180 (33.41)	990 (28.03)	900 (25.48)	810 (22.94)	750 (21.24)	690 (19.54)	650 (18.41)	620 (17.56)
2 (50.8)	2.067 (52.502)	3950 (111.85)	2750 (77.87)	2200 (62.30)	1900 (53.80)	1680 (47.57)	1520 (43.04)	1400 (39.64)	1300 (36.81)	1220 (34.55)	1150 (32.56)
2-1/2 (63.5)	2.469 (67.713)	6300 (178.39)	4350 (123.17)	3520 (99.67)	3000 (84.95)	2650 (75.04)	2400 (67.96)	2250 (63.71)	2050 (58.05)	1950 (55.22)	1850 (52.38)
3 (76.2)	3.068 (77.927)	11000 (311.48)	7700 (218.03)	6250 (176.98)	5300 (150.07)	4750 (134.50)	4300 (121.76)	3900 (110.43)	3700 (104.77)	3450 (97.69)	3250 (92.03)
4 (101.6)	4.026 (102.260)	23000 (651.27)	15800 (447.39)	12800 (362.44)	10900 (308.64)	9700 (274.67)	8800 (249.18)	8100 (229.36)	7500 (212.37)	7200 (203.88)	6700 (189.72)

NOTE: Capacity given in cubic feet of gas per hour (kilo liters of gas per hour) and based on 0.60 specific gravity gas.

Table 9

Electrical

ELECTROSTATIC DISCHARGE (ESD) Precautions and Procedures



Electrostatic discharge can affect electronic components. Take precautions during furnace installation and service to protect the furnace's electronic controls. Precautions will help to avoid control exposure to electrostatic discharge by putting the furnace, the control and the technician at the same electrostatic potential. Neutralize electrostatic charge by touching hand and all tools on an unpainted unit surface, such as the gas valve or blower deck, before performing any service procedure.

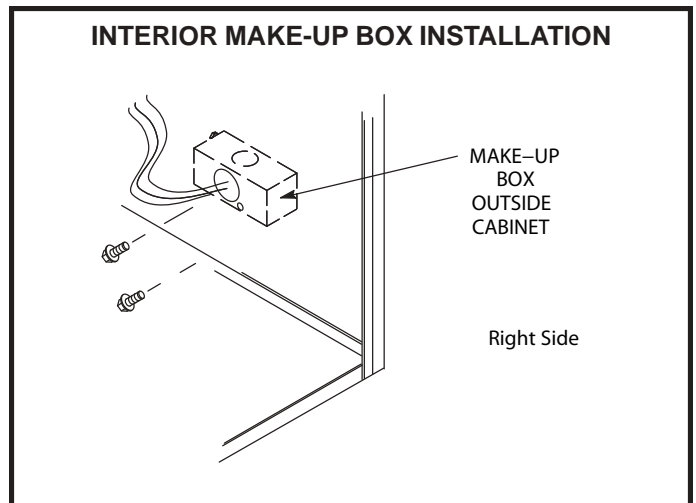

Figure 39

The unit is equipped with a field makeup box. The makeup box may be moved to the right side of the furnace to facilitate installation. If the make up box is moved to the right side, clip the wire ties that bundle the wires together. The excess wire must be pulled into the blower compartment. Secure the excess wire to the existing harness to protect it from damage. Seal unused openings on left side with plugs removed from right side.

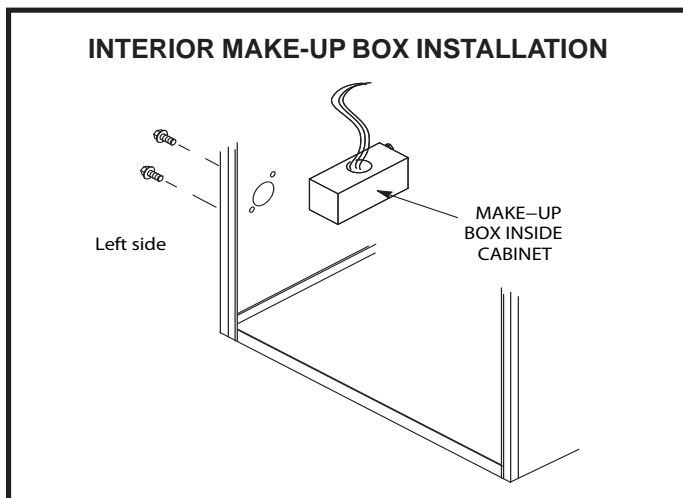

Figure 38

Refer to Figure 42 for unit field wiring. See Figure 44 and 45 for wiring of Comfort Sync™ thermostat in communicating applications. Tables 13 through 21 shows DIP switch and onboard link settings for non-communicating thermostat applications. Typical wiring schematic is shown in Figure 43.

1. The power supply wiring must meet Class I restrictions. Protected by either a fuse or circuit breaker, select circuit protection and wire size according to unit nameplate.

NOTE: Unit nameplate states maximum current draw. See table for maximum over-current protection.

Model	Maximum Over Current Protection (Amps)
070B, 090C12, C16	15
090C20, 110C20	20

Table 10

2. Holes are on both sides of the furnace cabinet to facilitate wiring.
3. Install a separate (properly sized) disconnect switch near the furnace so that power can be turned off for servicing.
4. Before connecting the thermostat check to make sure the wires will be long enough for servicing at a later date. Make sure that the thermostat wire is long enough to facilitate future removal of blower for service.
5. Complete the wiring connections to the equipment. Use the provided unit wiring diagram and the field wiring diagram shown in Figure 40 and Table 11. Use 18 gauge wire or larger that is suitable for Class II rating for thermostat connections.
6. Electrically ground the unit according to local codes or, in the absence of local codes, according to the current National Electric Code (ANSI/HFPA No. 70) for the USA and current Canadian Electric Code Part 1 (CSA standard C22.1) for Canada. A green ground wire is provided in the field make up box.
7. One line voltage "EAC" 1/4" spade terminal is provided on the furnace integrated control. Any electronic air cleaner or other 120V accessory rated up to **one amp** can be connected to this terminal with the neutral leg of the circuit being connected to one of the provided neutral terminals. See Figure 45 for location of terminal. This terminal is energized when the indoor blower is operating.
8. One line voltage "hum" 1/4" spade terminal is provided on the furnace integrated control. Any humidifier rated up to one amp can be connected to this terminal with the neutral leg of the circuit being connected to one of the provided neutral terminals. See Figure 46 for location of terminal. This terminal is energized in the heating mode when the indoor blower is operating.
9. One 24V "H" terminal is provided on the furnace integrated control terminal block. Any humidifier rated up to 0.5 amp can be connected to this terminal with the ground leg of the circuit being connected to either ground or the "C" terminal. See Figure 46 for location of terminal.

10. Install the room thermostat according to the instructions provided with the thermostat. See Table 11 for thermostat connections. If the furnace is being matched with a heat pump, refer to the instruction packaged with the dual fuel thermostat.

Thermostat Selection

The unit is designed to operate in a variable rate capacity mode using a two stage thermostat. This unit will automatically adjust firing rate based upon thermostat cycle times.

A Comfort Sync™ thermostat must be used in communicating applications. Refer to the instructions provided with the thermostat for installation, set up and operation.

For optimal performance in non-communicating applications, a thermostat with adjustable settings for 1st stage /2nd stage on/off differentials and adjustable stage timer is recommended.

The Following two stage thermostat set-up is recommended for optimal variable rate capacity mode:

First heat stage differential set to 1/2 to 1 degree F; second heat stage differential set to 1/2 or 1 degree F; second heat stage upstage timer disabled, or set to maximum (1 hr minimum).

Indoor Blower Speeds

NOTE: When this unit is used with a Comfort Sync™ thermostat, proper indoor blower speed selections are made by the communicating thermostat.

1. When the thermostat is set to "FAN ON", the indoor blower will run continuously at 38% percent of the second stage cooling speed when there is no cooling or heating demand.
2. When the unit is running in the heating mode, the integrated control will automatically adjust the blower speed to match the furnace firing rate. This speed can be adjusted up or down by 7.5% or 15% using DIP switches 14 through 16 for the low heat speed and 17 through 19 for the high heat speed.
3. When there is a cooling demand, the indoor blower will run on the cooling speed designated by the positions of DIP switches 8 through 11.

NOTE: The discharge air temperature sensor is intended to be mounted downstream of the heat exchanger and air conditioning coil. It must be placed in free airflow, where other accessories (humidifiers, UV lights etc.) will not interfere with its accuracy. Wiring distance between the furnace and discharge air sensor should not exceed 10 ft. when wired with 18 gauge thermostat wire.

Run Length – Non Communicating

Wire Run Length	AWG#	Insulation / Core Types
Less than 100' (30 m)	18	Color coded, temperature rating 95° F (35° C) minimum, solid core. (Class II Rated Wiring)
More than 100' (30 m)	16	

Table 11

Run Length – Communicating

Wire Run Length	AWG #	Insulation / Core Types
Maximum length of wiring for all connections on the RSBus is limited to 1500 feet (457 meters).	18	Color coded, temperature rating 95° F (36° C) Minimum, solid core. (Class II Rated Wiring)

Table 12

Generator Use - Voltage Requirements

The following requirements must be kept in mind when specifying a generator for use with this equipment:

- The furnace requires 120 volts \pm 10% (Range: 108 volts to 132 volts).
- The furnace operates at 60 Hz \pm 5% (Range: 57 Hz to 63 Hz).
- The furnace integrated control requires both polarity and proper ground. Both polarity and proper grounding should be checked before attempting to operate the furnace on either permanent or temporary power.
- Generator should have a wave form distortion of less than 5% THD (Total Harmonic Distortion).

Typical A97USMV Field Wiring Diagram for Standard Non-Communicating Thermostat

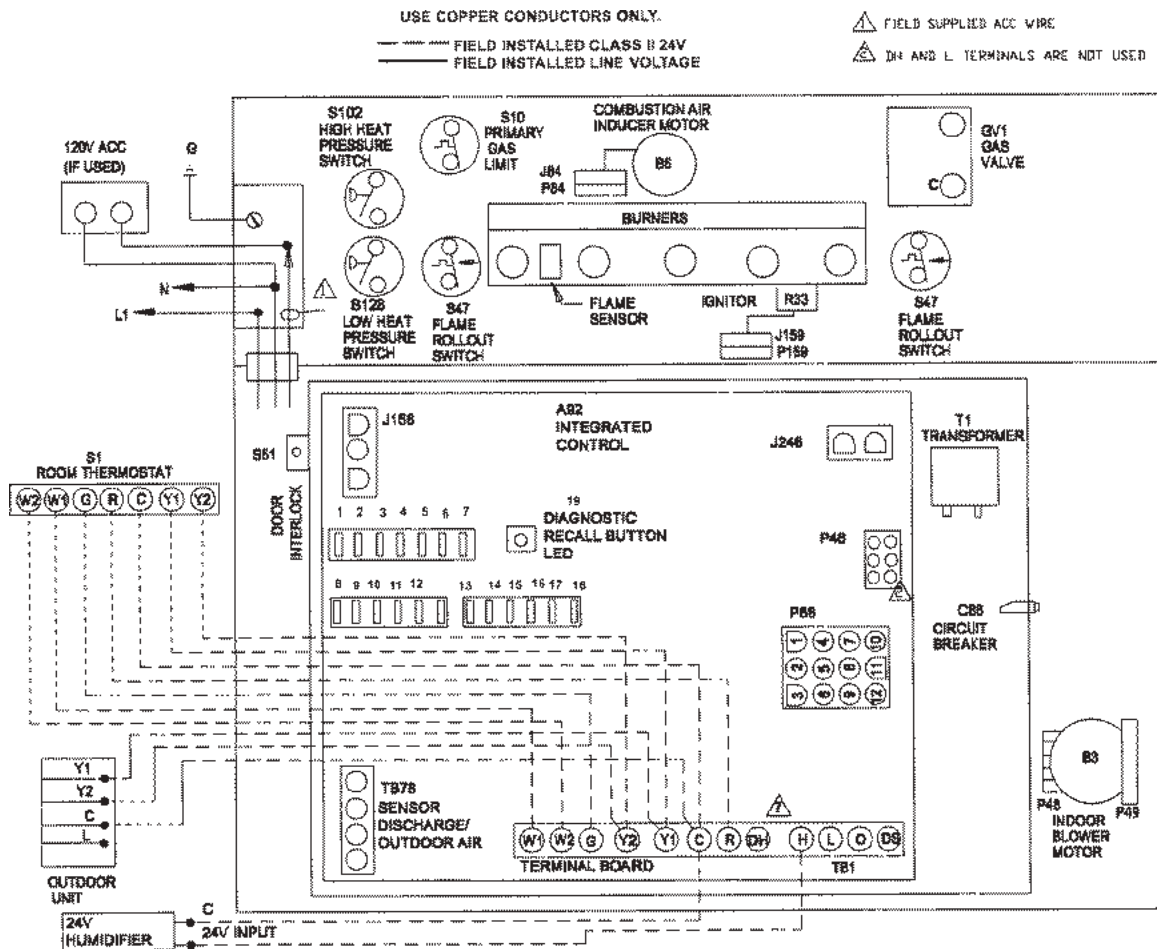

Figure 42

Typical A97DSMV Wiring Diagram



Figure 43

Comfort Sync™ Thermostat with A97DSMV and Non-Communicating Outdoor Unit

Comfort Sync™ Thermostat
 Comfort Sync™ Enabled A97DSMV Indoor Furnace
 Non-Communicating Outdoor Air Conditioner

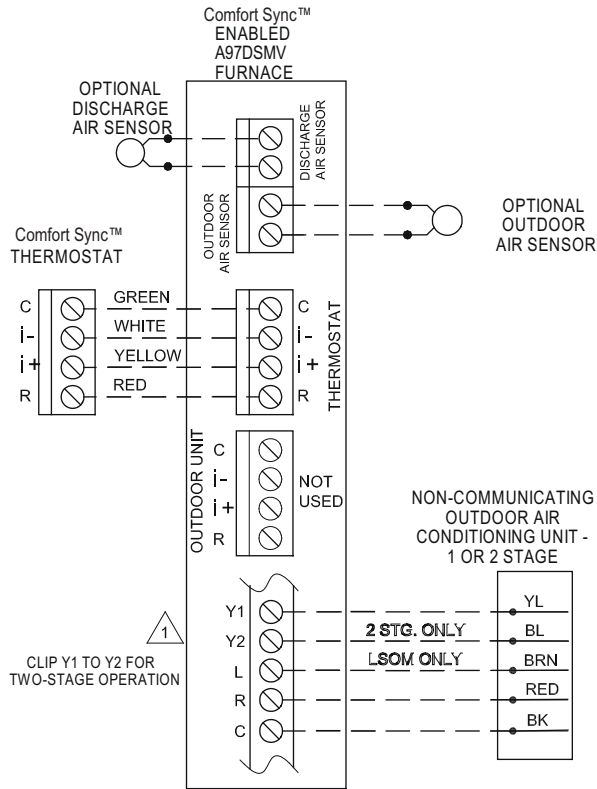

Comfort Sync™ Thermostat with A97DSMV Comfort Sync™-ENABLED Outdoor Unit

Comfort Sync™ Thermostat
 Comfort Sync™ -Enabled A97DSMV Indoor Furnace
 Comfort Sync™-Enabled Outdoor Air Conditioner or Heat Pump

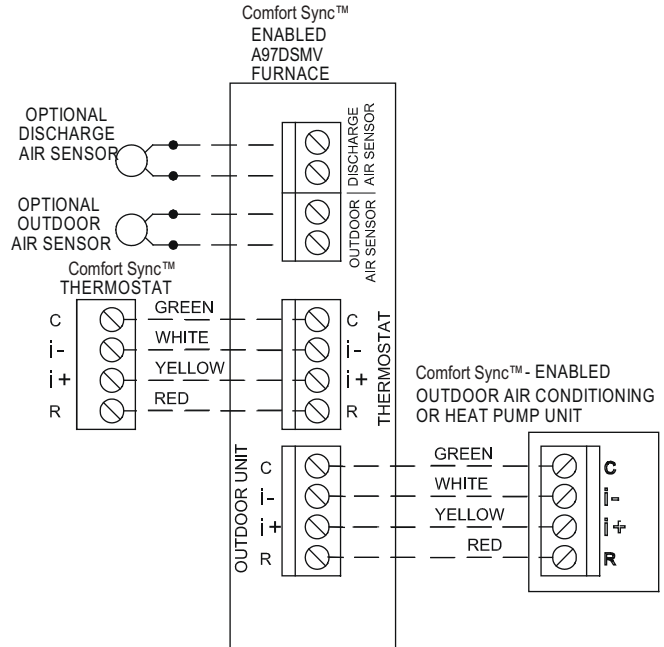

Figure 45

Optional Accessories for use with any Comfort Sync™ System

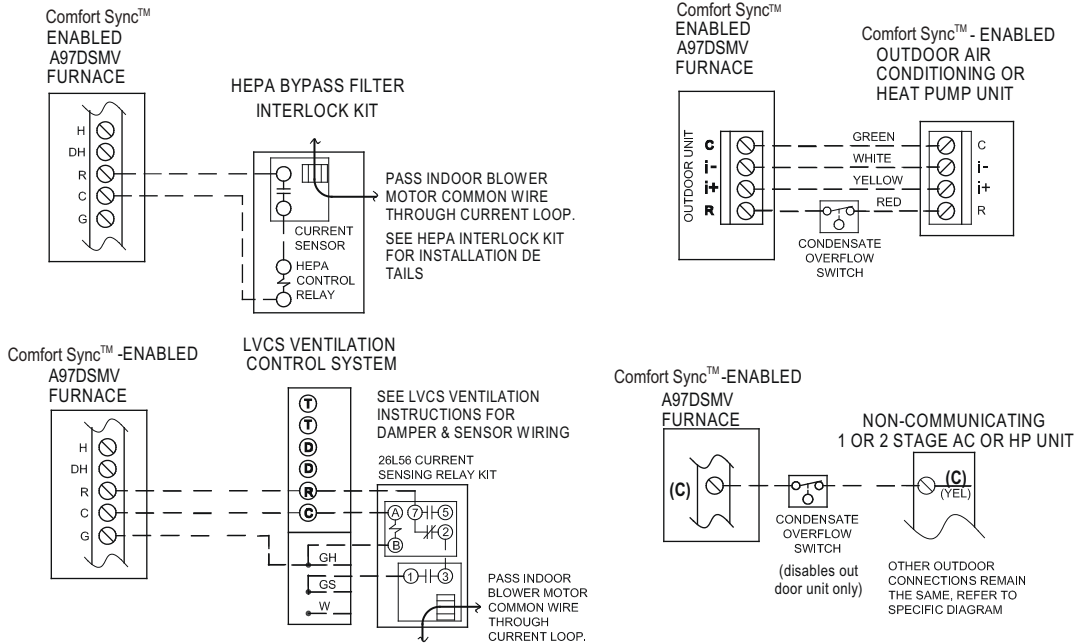
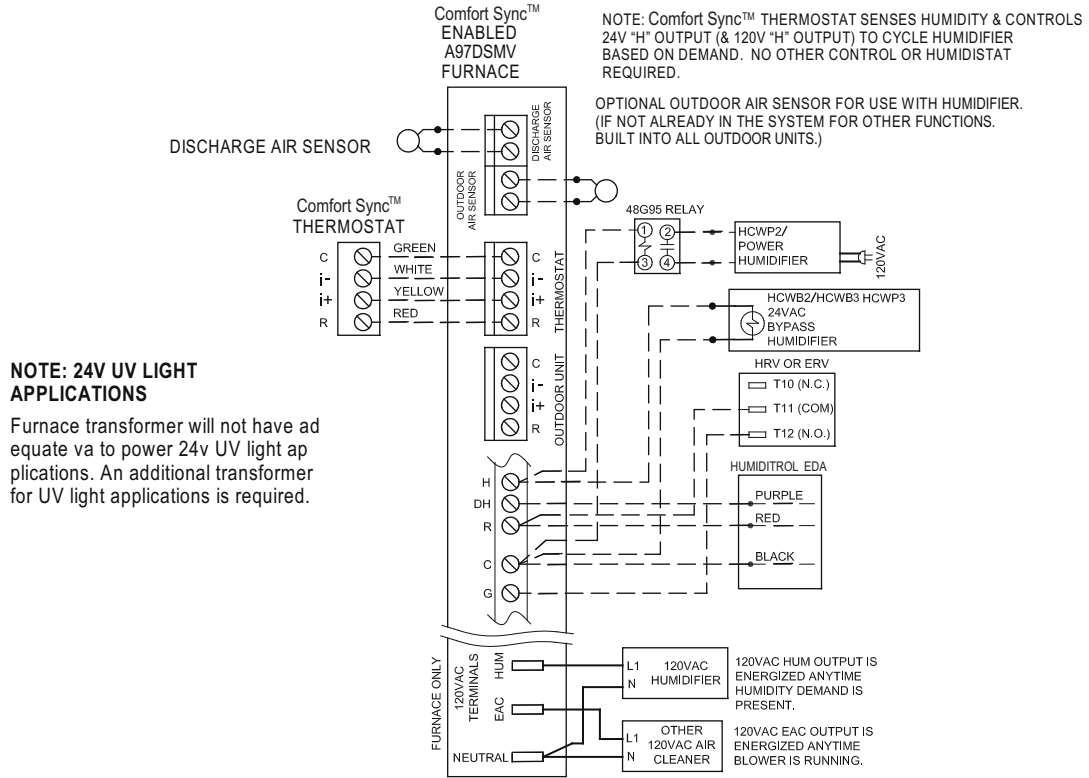
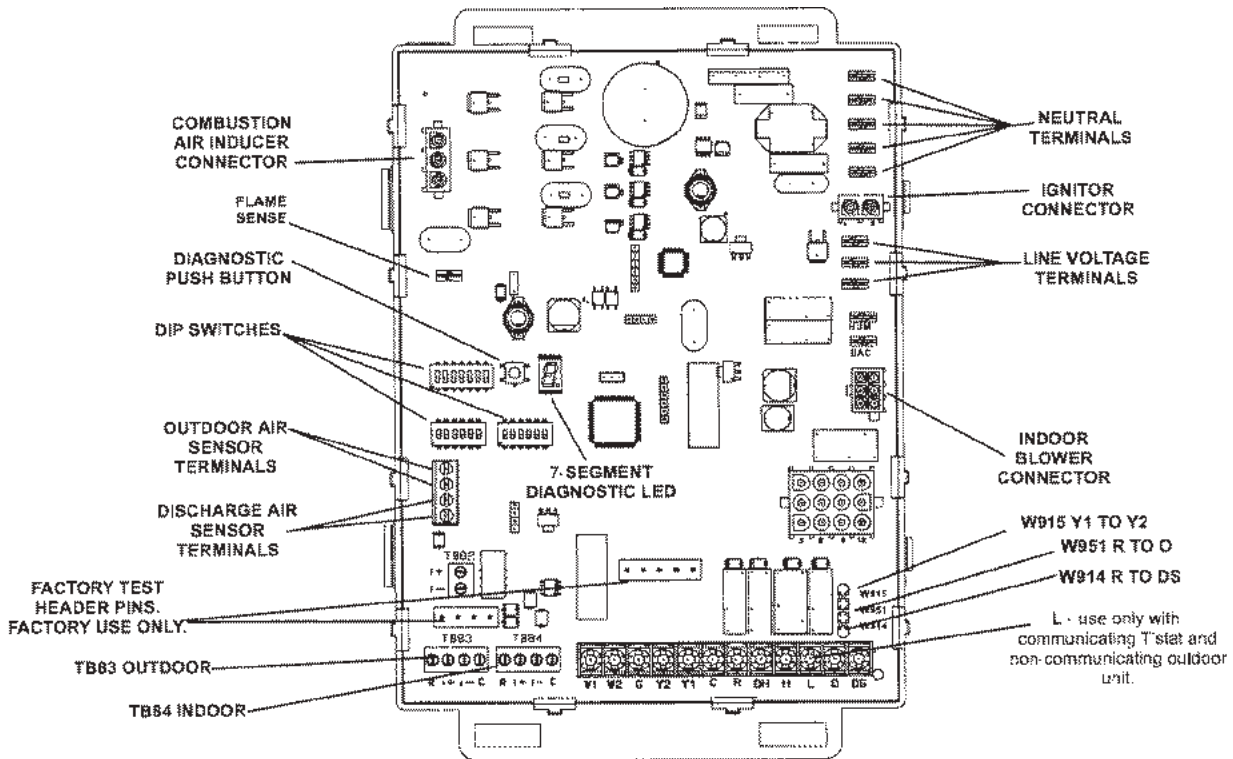

Figure 46

Integrated Control



RS-BUS LINK (TB82, future use)

I+ = DATA HIGH CONNECTION
I- = DATA LOW CONNECTION

RS-BUS OUTDOOR (TB83)

R = 24VAC
I+ = DATA HIGH CONNECTION
I- = DATA LOW CONNECTION
C = 24VAC COMMON

RS-BUS INDOOR (TB84)

R = 24VAC
I+ = DATA HIGH CONNECTION
I- = DATA LOW CONNECTION
C = 24VAC COMMON

1/4" QUICK CONNECT TERMINALS

HUM = 120 VAC OUTPUT TO HUMIDIFIER
XMF_R = 120 VAC OUTPUT TO TRANSFORMER
LI = 120 VAC INPUT TO CONTROL
CIRC = 120 VAC OUTPUT TO CIRCULATING BLOWER
EAC = 120 VAC OUTPUT TO ELECTRICAL AIR CLEANER
NEUTRALS = 120 VAC NEUTRAL

THERMOSTAT CONNECTIONS (TB1)

DS = DEHUMIDIFICATION SIGNAL
W2 = HEAT DEMAND FROM 2ND STAGE T/STAT
W1 = HEAT DEMAND FROM 1ST STAGE T/STAT
R = CLASS 2 VOLTAGE TO THERMOSTAT
G = MANUAL FAN FROM T/STAT
C = THERMOSTAT SIGNAL GROUND CONNECTED TO TRANSFORMER GRD (TR) & CHASSIS GROUND (GRD)
Y1 = THERMOSTAT 1ST STAGE COOL SIGNAL
Y2 = THERMOSTAT 2ND STAGE COOL SIGNAL
O = THERMOSTAT SIGNAL TO HEAT PUMP REVERSING VALVE
H = 24V HUMIDIFIER OUTPUT. DO NOT CONNECT TO THERMOSTAT
L = USE ONLY WITH A COMMUNICATING THERMOSTAT AND A NON-COMMUNICATING OUTDOOR UNIT
DH = DEHUMIDIFICATION OUTPUT COMMUNICATING THERMOSTAT ONLY

Figure 47

Field Wiring Connections for Non-Communicating Thermostat Applications

Thermostat	DIP Switch Settings and On-Board Links (figure NO TAG)			Wiring Connections	
	DIP Switch 1	W915 (Y1 to Y2) Two-Stage Cooling	W914 (DS to R) Dehumidifica tion or Harmony III™		W951 (O to R) Heat Pumps
1Heat / 1 Cool <i>NOTE - Use DIP switch 3 to set second-stage heat ON delay. OFF-7 minutes. ON-12 minutes.</i>	ON	Intact	Intact	Intact	<p>Wiring diagram for 1Heat / 1 Cool: S1 T'STAT terminals W, R, G, C, Y are connected to CONTROL TERM. STRIP terminals W1, R, G, C, Y1. The CONTROL TERM. STRIP terminals are also connected to OUTDOOR UNIT terminals R, C, Y. A note indicates that terminal R on the outdoor unit is required on some units.</p>
1 Heat / 2 Cool <i>NOTE - Use DIP switch 3 to set second-stage heat ON delay. OFF-7 minutes. ON-12 minutes.</i>	ON	Cut	Intact	Intact	<p>Wiring diagram for 1 Heat / 2 Cool: S1 T'STAT terminals W, R, G, C, Y2, Y1 are connected to CONTROL TERM. STRIP terminals W1, R, G, C, Y2, Y1. The CONTROL TERM. STRIP terminals are also connected to OUTDOOR UNIT terminals R, C, Y2, Y1. A note indicates that terminal R on the outdoor unit is required on some units.</p>
1 Heat / 2 Cool with t'stat with dehumidification mode <i>NOTE - Use DIP switch 3 to set second-stage heat ON delay. OFF-7 minutes. ON-12 minutes.</i>	ON	Cut	Cut	Intact	<p>Wiring diagram for 1 Heat / 2 Cool with dehumidification mode: S1 T'STAT terminals D, W1, R, G, C, Y2, Y1 are connected to CONTROL TERM. STRIP terminals DS, W1, R, G, C, Y2, Y1. The CONTROL TERM. STRIP terminals are also connected to OUTDOOR UNIT terminals R, C, Y2, Y1. A note indicates that terminal R on the outdoor unit is required on some units.</p>

***R" required on some units.*

Table 13A

Field Wiring for Non-Communicating Applications (continued)

Thermostat	DIP Switch Settings and On-Board Links (figure NO TAG)			Wiring Connections	
	DIP Switch 1	W915 (Y1 to Y2) Two-Stage Cooling	W914 (DS to R) Dehumidific ation or Harmony III™		W951 (O to R) Heat Pumps
2 Heat / 2 Cool	OFF	Cut	Intact	Intact	
2 Heat / 2 Cool with t'stat with dehumidification mode	OFF	Cut	Cut	Intact	
2 Heat / 1 Cool	OFF	Intact	Intact	Intact	

* "R" required on some units.

Table 13B

Field Wiring for Non-Communicating Applications (continued)

Thermostat	DIP Switch Settings and On-Board Links (figure NO TAG)			Wiring Connections	
	DIP Switch	W915 (Y1 to Y2) Two-Stage Cooling	W914 (DS to R) Dehumidification or Harmony III™		W951 (O to R) Heat Pumps
Dual Fuel Single-Stage Heat Pump thermostat w/ dual fuel capabilities Capable of 2- stage gas heat control	DIP Switch 1 OFF	Intact	Intact	Cut	
Dual Fuel Two Stage Heat Pump thermostat w/ dual fuel capabilities Capable of 2- stage gas heat control	DIP Switch 1 OFF	Cut	Intact	Cut	

* Connect W1 to W1 ONLY if using defrost tempering kit 67M41.

NOTE: Do NOT make a wire connection between the room thermostat L terminal and the L terminal of the A97USMV integrated control.

Table 13C

Low Voltage Field Wiring

Single Stage

Thermostat	DIP Switch Settings & On Board Links (Figure 41)			
	DIP Switch	W915 (Y1 to Y2) Two Stage Cooling	W914 (DS to R) Dehumidification	W951 (O to R) Heat Pumps
Dual Fuel Single Stage Heat Pump thermostat w/dual fuel capabilities Capable of 2 stage gas heat control	DIP Switch 1 OFF	Intact	Intact	Cut

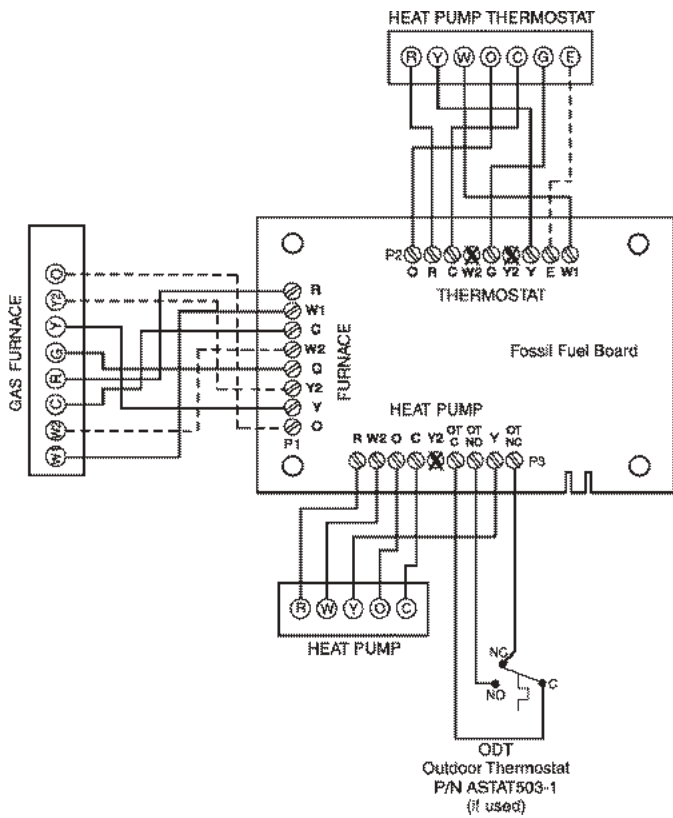

2 Stage

Thermostat	DIP Switch Settings & On Board Links (Figure 41)			
	DIP Switch	W915 (Y1 to Y2) Two Stage Cooling	W914 (DS to R) Dehumidification	W951 (O to R) Heat Pumps
Dual Fuel Two Stage Heat Pump thermostat w/dual fuel capabilities Capable of 2 stage gas heat control	DIP Switch 1 OFF	Cut	Intact	Cut

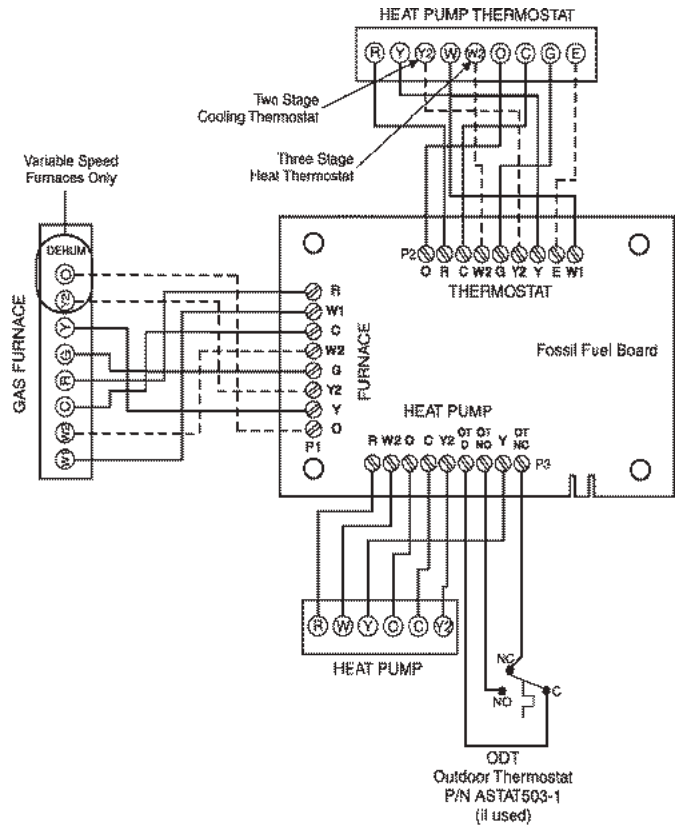

Table 14

Thermostat Selection Switch Settings				
Operation	Thermostat	Switch 1	Switch 2	Switch 3
Variable Capacity Heat (40% to 100%)	Two Stage	OFF	ON	OFF
Three Stage Heat (40%, 70%, 100%)	Single Stage	ON	OFF	2nd stage delay OFF = 7 minutes ON = 12 minutes 3rd stage delay 10 minutes fixed
Two Stage Heat (W1 70%, W2 100%)	Two Stage	OFF	OFF	OFF

Table 15

These units are equipped with an integrated control. This control manages ignition timing, combustion air inducer speed, heating mode fan OFF delays and indoor blower speeds based on selections made using the control DIP switches and onboard links. The control includes an internal feature which automatically resets the ignition control when it has been locked out.

NOTE: All DIP switches are factory shipped in the “OFF” position.

Heating Operation DIP Switch Settings - Figure 41

Switch 1 - Thermostat Selection - This unit may be used with either a single stage or two stage thermostat. The thermostat selection is made using a DIP switch which must be properly positioned for the particular application. The DIP switch is factory positioned for use with a two stage thermostat. If a single stage thermostat is to be used, the DIIP switch must be repositioned. See Table 12.

Switch 2 - Operating Mode with Two Stage Thermostat If a two stage thermostat is used, the furnace can operate in either variable capacity or conventional two stage mode. When variable capacity mode is selected, the firing rate of the unit is varied to maximize comfort. Conventional two stage mode is the factory default setting. See Table 12.

Switch 3 - Second Stage Heat On Delay - If a single stage thermostat is used, the integrated control can be used to energize second stage heat after either 7 minutes or 12 minutes of first stage heat operation. See Table 12.

Switches 4 and 5 - Blower Off Delay -The blower On delay of 30 seconds is not adjustable. The blower Off delay (time that the blower operates after the heating demand has been

satisfied) can be adjusted by moving switches 4 and 5 on the integrated control. The unit is shipped from the factory with a blower Off delay of 90 seconds. The blower Off delay affects comfort and is adjustable to satisfy individual applications. Adjust the blower Off delay to achieve a supply air temperature between 90° and 110° F at the exact moment that the blower is de-energized. Longer Off delay settings provide lower supply air temperatures; shorter settings provide higher supply air temperatures. Table 13 provides the blower Off timings that will result from different switch settings.

Blower Off Delay Switch Settings		
Blower Off Delay (Seconds)	Switch 4	Switch 5
60	Off	On
90 (factory)	Off	Off
120	On	Off
180	On	On

Table 16

Indoor Blower Operation DIP Switch Settings

Switches 6 and 7 - Continuous Indoor Fan Operation - Blower Speed - The unit is shipped from the factory with the DIP switches positioned for medium low (38%) speed during continuous indoor blower operation. Continuous fan setting is 38% of cool setting and is not adjustable.

Switches 8 and 9 - Cooling Mode Blower Speed-

The unit is shipped from the factory with the DIP switches positioned for high speed (4) indoor blower motor operation during the cooling mode. The table below provides the cooling mode blower speeds that will result from different switch settings.

Cooling Mode Blower Speeds		
Speed	Switch 8	Switch 9
1 - Low	On	On
2 - Medium Low	Off	On
3 - Medium High	On	Off
4 - High (Factory)	Off	Off

Table 17

Switches 10 and 11 - Cooling Mode Blower Speed Adjustment

The unit is shipped from the factory with the DIP switches positioned for NORMAL (no) adjustment. The DIP switches may be positioned to adjust the blower speed by +10% or -10% to better suit the application. Table 18 provides blower speed adjustments that will result from different switch settings. Refer to air flow tables for values.

With switches 10 and 11 set to ON, motor will bypass ramping profiles and all delays and will immediately run at selected COOLING speed upon a call for cool. LED will continue to operate as normal. This mode is used to check motor operation.

Cooling Mode Blower Speed Adjustment		
Adjustment	Switch 10	Switch 11
+ 10% (approx.)	On	Off
NORMAL (Factory)	Off	Off
- 10% (approx.)	Off	On
MOTOR TEST	On	On

Table 18

Switches 12 and 13 - Cooling Mode Blower Speed Ramping

Blower speed ramping may be used to enhance dehumidification performance. The switches are factory set at option A which has the greatest effect on blower motor performance. Table 19 provides the cooling mode blower speed ramping options that will result from different switch settings. The cooling mode blower speed ramping options are detailed below.

NOTE: The OFF portion of the selected ramp profile only applies during heat pump operation in dual fuel applications.

Cooling Mode Blower Speed Ramping		
Ramping Option	Switch 12	Switch 13
A (Factory)	Off	Off
B	On	Off
C	Off	On
D	On	On

Table 19

Ramping Option "A" (Factory Selection)

- Motor runs at 50% for 30 seconds.
- Motor then runs at 82% for approximately 7-1/2 minutes.
- If demand has not been satisfied after 7-1/2 minutes, motor runs at 100% until demand is satisfied.
- Once demand is met, motor runs at 50% for 30 seconds then ramps down to stop.

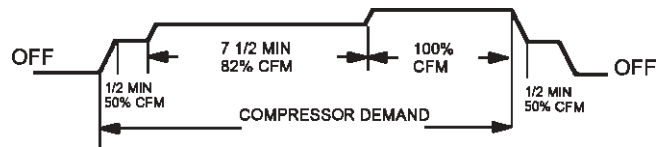

Ramping Option "B"

- Motor runs at 82% for approximately 7-1/2 minutes. If demand has not been satisfied after 7-1/2 minutes, motor runs at 100% until demand is satisfied.
- Once demand is met, motor ramps down to stop.



Ramping Option "C"

- Motor runs at 100% until demand is satisfied.
- Once demand is met, motor runs at 100% for 45 seconds then ramps down to stop.

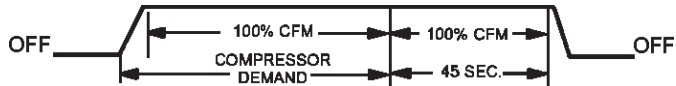

Ramping Option "D"

- Motor runs at 100% until demand is satisfied.
- Once demand is met, motor ramps down to stop.



Switches 14 through 19 - Heating Mode Blower Speed

These switches are factory set at the OFF position which provides 100% of normal speed during HIGH HEAT demand, 70% of normal speed during MIDRANGE HEAT demand and 40% of normal speed during LOW HEAT demand. Switches 14, 15 and 16 are used to adjust the LOW HEAT blower motor speed. Switches 17, 18 and 19 are used to adjust the HIGH HEAT blower motor speed. Table 18 provides the heating mode blower speeds that will result from different switch settings.

Low Heat Blower Speeds

Thermostat Demand	Blower Speed Adjustments	DIP SWITCH SETTINGS		
		14	15	16
Low Heat (R to W1)	+15%	On	Off	On
	+7.5%	On	Off	Off
	Normal	Off	Off	Off
	-7.5%	On	On	Off
	-15%	On	On	On

Table 20

High Heat Blower Speeds

Thermostat Demand	Blower Speed Adjustments	DIP SWITCH SETTINGS		
		17	18	19
High Heat (R to W1 & W2)	+15%	On	Off	On
	+7.5%	On	Off	Off
	Normal	Off	Off	Off
	-7.5%	On	On	Off
	-15%	On	On	On

Table 21

On Board Links

On Board links must be clipped (when applicable) before unit is placed into operation with a non-communicating thermostat.

On Board Link W914 DS to R (Figure??)

On Board link W914, is a clippable connection between terminals DS and R on the integrated control. W914 must be cut when installed with a thermostat which features humidity control. Refer to Table ?? for operation sequence in applications for this unit, a thermostat which features humidity control and a single speed outdoor unit. Table ?? gives the operation sequence in applications with a two speed outdoor unit.

On Board Link W951 R to O (Figure ??)

On Board link W951 is a clippable connection between terminals R and O on the integrated control. W951 must be cut when the furnace is installed in applications which include a heat pump unit and thermostat which features dual fuel use. If the link is left intact, terminal "O" will remain energized eliminating the HEAT MODE in the heat pump.

On Board Link W915 Y1 to Y2 (Figure ??)

On Board link W915 is a clippable connection between terminals Y1 and Y2 on the integrated control. W915 must be cut if two stage cooling will be used. If the link is not cut the outdoor unit will operate in second stage cooling only.

Diagnostic LED (Figure ??)

The seven segment diagnostic LED displays operating status, target airflow, error codes and other information. The table on page 58 lists diagnostic LED codes.

Diagnostic Push Button (Figure ??)

The diagnostic push button is located adjacent to the seven segment diagnostic LED. This button is used to enable the Error Code Recall mode and the Field Test mode. Press the button and hold it to cycle through a menu of options. Every five seconds a new menu item will be displayed. When the button is released, the displayed item will be selected. Once all items in the menu have been displayed, the menu resumes from the beginning until the button is released.

Error Code Recall Mode

Select "E" from the menu to access the most recent 10 error codes. Select "c" from the Error Code Recall menu to clear all error codes. Button must be pressed a second time while "c" is flashing to confirm command to delete codes. Press the button until a solid "-" is displayed to exit the Error Code Recall mode.

Field Test Mode

Use the diagnostic push button to scroll through the menu as described above. Release the button when the LED flashes "-" to select the Field Test mode.

While in the Field Test mode the technician can:

- Initiate furnace ignition and move to and hold low-fire rate by applying a R to W1 jumper.
- Initiate furnace ignition sequence and move to an hold high-fire rate by applying a jumper from R to W1 and W2.
- Initiate furnace ignition sequence and move to and hold mid-fire rate by applying a jumper to R and W2.
- Apply then remove the jumper from R to W1 and W2 to change the firing rate from low fire to mid fire and high fire.
- A vent calibration sequence can be initiated even if a thermostat signal is not present. Press and hold the push button until a solid "C" is displayed. Release the button and calibration will begin. The furnace will perform the high-fire and low-fire pressure switch calibrations and display "CAL". After calibration, the LED will return to the flashing "-" display.

During Field Test mode operation, all safety switches are still in the circuit (they are not by-passed) and indoor blower performance and timings will match DIP switch selections. Current furnace firing rate, indoor blower CFM and flame signal will be displayed. To exit the Field Test mode, press and hold the button. The menu will resume from the beginning. Also, cycle the main power to exit the Field Test mode. The integrated control will automatically exit the Field Test mode after 45 minutes of operation

BLOWER DATA

BLOWER DATA

A97DSMV070B12S BLOWER PERFORMANCE (less filter)

HEATING BLOWER PERFORMANCE

Heating Adjust CFM Selections	Heating Input Range and Blower Volume - CFM						
	40%	50%	60%	70%	80%	90%	100%
Increase (+15%) Heat CFM	520	615	710	805	900	1000	1095
Increase (+7.5%) Heat CFM	485	575	665	755	840	930	1020
Default Heat CFM	450	535	615	700	785	865	950
Decrease (-7.5%) Heat CFM	415	495	570	650	725	800	880
Decrease (-15%) Heat CFM	385	455	525	595	665	735	810

COOLING BLOWER PERFORMANCE

Cooling Adjust CFM Selections	Blower Speed Selections							
	First Stage Cooling Speed - cfm				Second Stage Cooling Speed - cfm			
	Low	Medium Low	Medium High	High (Default)	Low	Medium Low	Medium High	High (Default)
Increase (+10%) Cool CFM	605	745	855	965	880	1045	1210	1375
Default Cool CFM	550	675	775	875	800	950	1100	1250
Decrease (-10%) Cool CFM	495	610	700	790	720	855	980	1125

The effect of static pressure is included in air volumes shown.

The following control configurations are available. See Installation Instructions for details and DIP switch settings.

Heat Modes Available (Heating Blower Performance Table):

Single stage thermostat:

- 40%, 70%, 100% input (three-stage) with time delays in-between

Two-stage thermostat:

- Variable Rate Capacity Mode - furnace automatically adjusts firing rate based on first- and second-stage cycle times
- W1 demand at 70% input, W2 demand at 100% input. No delay between stages

Cool Mode Available (Cooling Blower Performance table):

First stage COOL (two-stage air conditioning units only) is approximately 70% of the same second stage COOL speed position.

Continuous Fan speeds are approximately 38% of the same second-stage COOL speed position minimum 300 cfm.

BLOWER DATA

A97DSMV090C16S BLOWER PERFORMANCE (less filter)

HEATING BLOWER PERFORMANCE

Heating Adjust CFM Selections	Heating Input Range and Blower Volume - CFM						
	40%	50%	60%	70%	80%	90%	100%
Increase (+15%) Heat CFM	775	910	1045	1180	1315	1450	1580
Increase (+7.5%) Heat CFM	725	850	975	1100	1230	1355	1480
Default Heat CFM	675	790	910	1025	1140	1260	1375
Decrease (-7.5%) Heat CFM	625	730	840	950	1055	1165	1270
Decrease (-15%) Heat CFM	575	675	770	870	970	1070	1170

COOLING BLOWER PERFORMANCE

Cooling Adjust CFM Selections	Blower Speed Selections							
	First Stage Cooling Speed - cfm				Second Stage Cooling Speed - cfm			
	Low	Medium Low	Medium High	High (Default)	Low	Medium Low	Medium High	High (Default)
Increase (+10%) Cool CFM	770	935	1075	1240	1100	1320	1540	1760
Default Cool CFM	700	850	975	1125	1000	1200	1400	1600
Decrease (-10%) Cool CFM	630	765	880	1015	900	1080	1260	1440

The effect of static pressure is included in air volumes shown.

The following control configurations are available. See Installation Instructions for details and DIP switch settings.

Heat Modes Available (Heating Blower Performance Table):

Single stage thermostat:

- 40%, 70%, 100% input (three-stage) with time delays in-between

Two-stage thermostat:

- Variable Rate Capacity Mode - furnace automatically adjusts firing rate based on first- and second-stage cycle times
- W1 demand at 70% input, W2 demand at 100% input. No delay between stages

Cool Mode Available (Cooling Blower Performance table):

First stage COOL (two-stage air conditioning units only) is approximately 70% of the same second stage COOL speed position.

Continuous Fan speeds are approximately 38% of the same second-stage COOL speed position minimum 300 cfm.

BLOWER DATA

BLOWER DATA
A97DSMV090C20S BLOWER PERFORMANCE (less filter)
HEATING BLOWER PERFORMANCE

Heating Adjust CFM Selections	Heating Input Range and Blower Volume - CFM						
	40%	50%	60%	70%	80%	90%	100%
Increase (+15%) Heat CFM	775	910	1045	1180	1315	1450	1580
Increase (+7.5%) Heat CFM	725	850	975	1100	1230	1355	1480
Default Heat CFM	675	790	910	1025	1140	1260	1375
Decrease (-7.5%) Heat CFM	625	730	840	950	1055	1165	1270
Decrease (-15%) Heat CFM	575	675	770	870	970	1070	1170

COOLING BLOWER PERFORMANCE

Cooling Adjust CFM Selections	Blower Speed Selections							
	First Stage Cooling Speed - cfm				Second Stage Cooling Speed - cfm			
	Low	Medium Low	Medium High	High (Default)	Low	Medium Low	Medium High	High (Default)
Increase (+10%) Cool CFM	935	1075	1240	1405	1320	1540	1760	2010
Default Cool CFM	850	975	1125	1275	1200	1400	1600	1825
Decrease (-10%) Cool CFM	765	880	1015	1150	1080	1260	1440	1645

The effect of static pressure is included in air volumes shown.

The following control configurations are available. See Installation Instructions for details and DIP switch settings.

Heat Modes Available (Heating Blower Performance Table):

Single stage thermostat:

- 40%, 70%, 100% input (three-stage) with time delays in-between

Two-stage thermostat:

- Variable Rate Capacity Mode - furnace automatically adjusts firing rate based on first- and second-stage cycle times
- W1 demand at 70% input, W2 demand at 100% input. No delay between stages

Cool Mode Available (Cooling Blower Performance table):

First stage COOL (two-stage air conditioning units only) is approximately 70% of the same second stage COOL speed position.

Continuous Fan speeds are approximately 38% of the same second-stage COOL speed position minimum 300 cfm.

BLOWER DATA
A97DSMV110C20S BLOWER PERFORMANCE (less filter)
HEATING BLOWER PERFORMANCE

Heating Adjust CFM Selections	Heating Input Range and Blower Volume - CFM						
	40%	50%	60%	70%	80%	90%	100%
Increase (+15%) Heat CFM	890	1085	1275	1465	1660	1850	2040
Increase (+7.5%) Heat CFM	830	1010	1190	1370	1550	1730	1910
Default Heat CFM	775	940	1110	1275	1440	1610	1775
Decrease (-7.5%) Heat CFM	720	870	1025	1180	1335	1490	1640
Decrease (-15%) Heat CFM	660	800	940	1085	1225	1365	1510

COOLING BLOWER PERFORMANCE

Cooling Adjust CFM Selections	Blower Speed Selections							
	First Stage Cooling Speed - cfm				Second Stage Cooling Speed - cfm			
	Low	Medium Low	Medium High	High (Default)	Low	Medium Low	Medium High	High (Default)
Increase (+10%) Cool CFM	935	1075	1240	1405	1320	1540	1760	2010
Default Cool CFM	850	975	1125	1275	1200	1400	1600	1825
Decrease (-10%) Cool CFM	765	880	1015	1150	1080	1260	1440	1645

The effect of static pressure is included in air volumes shown.

The following control configurations are available. See Installation Instructions for details and DIP switch settings.

Heat Modes Available (Heating Blower Performance Table):

Single stage thermostat:

- 40%, 70%, 100% input (three-stage) with time delays in-between

Two-stage thermostat:

- Variable Rate Capacity Mode - furnace automatically adjusts firing rate based on first- and second-stage cycle times
- W1 demand at 70% input, W2 demand at 100% input. No delay between stages

Cool Mode Available (Cooling Blower Performance table):

First stage COOL (two-stage air conditioning units only) is approximately 70% of the same second stage COOL speed position.

Continuous Fan speeds are approximately 38% of the same second-stage COOL speed position minimum 300 cfm.

COOLING OPERATING SEQUENCE
A97DSMV and Single Stage Outdoor Unit

OPERATING SEQUENCE		SYSTEM DEMAND					SYSTEM RESPONSE			
System Condition	Step	Demand			Relative Humidity		Compressor	Blower CFM (COOL)	Comments	
		1st stage	O	G	Status	D*				
<i>NO CALL FOR DEHUMIDIFICATION</i>										
Normal Operation	1	On	On	On	Acceptable	24 VAC	High	100%	Compressor and indoor blower follow thermostat demand	
<i>BASIC MODE (only active on a Y1 thermostat demand)</i>										
Normal Operation	1	On	On	On	Acceptable	24 VAC	High	100%	Thermostat energizes Y1 and de-energizes D on a call for de-humidification	
Dehumidification Call	2	On	On	On	Demand	0 VAC	High	70%		
<i>PRECISION MODE (operates independent of a Y1 thermostat demand)</i>										
Normal Operation	1	On	On	On	Acceptable	24 VAC	High	100%	Dehumidification mode begins when humidity is greater than set point	
Dehumidification call	2	On	On	On	Demand	0 VAC	High	70%		
Dehumidification call ONLY	1	On	On	On	Demand	0 VAC	High	70%	Thermostat will keep outdoor unit energized after cooling temperature setpoint has been reached in order to maintain room humidity setpoint.	
On-board links at indoor unit with a single-stage outdoor unit: With Condensing unit - Cut W914 (R to DS) on control. With Heat Pump - Cut W914 (R to DS) & W951 (R to O) on control.										

Table 22

COOLING OPERATING SEQUENCE
A97DSMV and Two Stage Outdoor Unit

OPERATING SEQUENCE		SYSTEM DEMAND						SYSTEM RESPONSE		
System Condition	Step	Demand				Relative Humidity		Compressor	Blower CFM (COOL)	Comments
		1st stage	2nd stage	O	G	Status	D*			
NO CALL FOR DEHUMIDIFICATION										
Normal Operation - Y1	1	On		On	On	Acceptable	24 VAC	Low	70%	Compressor and indoor blower follow thermostat demand
Normal Operation - Y2	2	On	On	On	On	Acceptable	24 VAC	High	100%	
ROOM THERMOSTAT CALLS FOR FIRST STAGE COOLING										
<i>BASIC MODE (only active on a Y1 thermostat demand)</i>										
Normal Operation	1	On		On	On	Acceptable	24 VAC	Low	70%	Thermostat energizes 2nd stage and de-energizes D on a call for dehumidification
Dehumidification Call	2	On	On	On	On	Demand	0 VAC	High	70%	
<i>PRECISION MODE (operates independent of a Y1 thermostat demand)</i>										
Normal Operation	1	On		On	On	Acceptable	24 VAC	Low	70%	Dehumidification mode begins when humidity is greater than set point
Dehumidification call	2	On	On	On	On	Demand	0 VAC	High	70%	
Dehumidification call ONLY	1	On	On	On	On	Demand	0 VAC	High	70%	Thermostat will keep outdoor unit energized after cooling temperature setpoint has been reached in order to maintain room humidity setpoint.*
ROOM THERMOSTAT CALLS FOR FIRST AND SECOND STAGE COOLING										
<i>BASIC MODE (only active on a Y1 thermostat demand)</i>										
Normal Operation	1	On	On	On	On	Acceptable	24 VAC	High	100%	Thermostat energizes 2nd stage and de-energizes D on a call for dehumidification
Dehumidification Call	2	On	On	On	On	Demand	0 VAC	High	70%	
<i>PRECISION MODE (operates independent of a Y1 thermostat demand)</i>										
Normal Operation	1	On		On	On	Acceptable	24 VAC	Low	70%	Dehumidification mode begins when humidity is greater than set point
Dehumidification call	2	On	On	On	On	Demand	0 VAC	High	70%	
Dehumidification call ONLY	1	On	On	On	On	Demand	0 VAC	High	70%	Thermostat will keep outdoor unit energized after cooling temperature setpoint has been reached in order to maintain room humidity setpoint.
<p>On-board links at indoor unit with a two-stage outdoor unit: Cut factory link from Y1 to Y2 or cut W915 (Y1 to Y2) on integrated control.</p> <p>With Condensing unit - Cut W914 (R to DS) on integrated control; With Heat Pump - Cut W914 (R to DS) & W951 (R to O) on integrated control.</p>										

Table 23

Unit Start Up

FOR YOUR SAFETY READ BEFORE OPERATING

WARNING

Do not use this furnace if any part has been underwater. A flood damaged furnace is extremely dangerous. Attempts to use the furnace can result in fire or explosion. Immediately call a qualified service technician to inspect the furnace and to replace all gas controls, control system parts, and electrical parts that have been wet or to replace the furnace, if deemed necessary.

WARNING



Danger of explosion. Can cause injury or product or property damage. Should the gas supply fail to shut off or if overheating occurs, shut off the gas valve to the furnace before shutting off the electrical supply.

CAUTION

Before attempting to perform any service or maintenance, turn the electrical power to unit OFF at disconnect switch.

WARNING

During blower operation, the ECM motor emits energy that may interfere with pacemaker operation. Interference is reduced by both the sheet metal cabinet and distance.

Priming Condensate Trap

The condensate trap should be primed with water prior to startup to ensure proper condensate drainage. Either pour 10 fl. oz. (300 ml) of water into the trap, or follow these steps to prime the trap:

1. Follow the lighting instructions to place the unit into operation.
2. Set the thermostat to initiate a heating demand.
3. Allow the burners to fire for approximately 3 minutes.
4. Adjust the thermostat to deactivate the heating demand.
5. Wait for the combustion air inducer to stop. Set the thermostat to initiate a heating demand and again allow the burners to fire for approximately 3 minutes.
6. Adjust the thermostat to deactivate the heating demand and again wait for the combustion air inducer to stop. At this point, the trap should be primed with sufficient water to ensure proper condensate drain operation.

BEFORE PLACING THE UNIT INTO OPERATION

Smell all around the furnace area for gas. Be sure to smell next to the floor because some gas is heavier than air and will settle on the floor.

The gas valve on these units are equipped with a gas control switch. Use only your hand to move the control switch. Never use tools. If the switch will not move by hand, do not try to repair it. Force or attempted repair may result in a fire or explosion.

Placing the Furnace into Operation:

These units are equipped with an automatic ignition system. Do not attempt to manually light burners on this furnace. Each time the thermostat calls for heat, the burners will automatically light. The ignitor does not get hot when there is no call for heat on units with this ignition system.

WARNING

If you do not follow these instructions exactly, a fire or explosion may result causing property damage, personal injury or death.

Gas Valve Operation (Figure 48)

1. **STOP!** Read the safety information at the beginning of this section.
2. Set the thermostat to the lowest setting.
3. Turn **OFF** all electrical power to the unit.
4. This furnace is equipped with an ignition device which automatically lights the burners. **DO NOT** try to light the burners by hand.
5. Remove the access panel.
6. Move the gas valve switch to the **OFF** position. See Figure 48.
7. Wait five minutes to clear out any gas. If you then smell gas, **STOP!** Immediately call the gas supplier from a neighbor's phone. Follow the gas supplier's instructions. If you do not smell gas go to the next step.
8. Move gas valve switch to the **ON** position. See Figure 48. **DO Not** force.

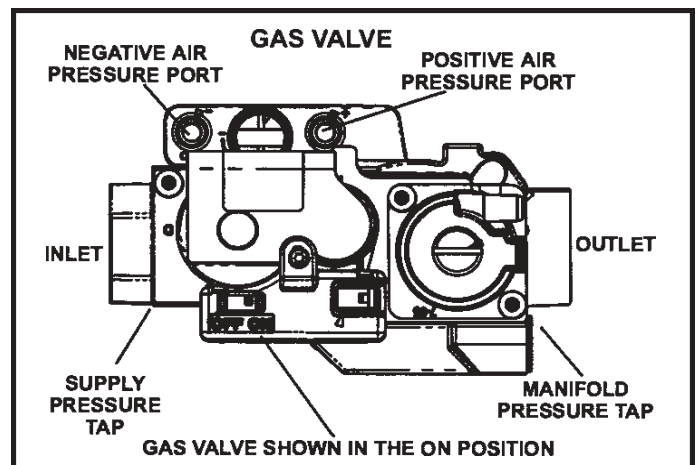

Figure 48

9. Replace the access panel.
10. Turn on all electrical power to the unit.
11. Set the thermostat to desired setting.

NOTE: When unit is initially started, steps 1 through 11 may need to be repeated to purge air from gas line.

12. If the Appliance will not operate, follow the instructions "Turning Off Gas to Unit" and call the gas supplier.

Turning Off Gas to Unit

1. Set the thermostat to the lowest setting.
2. Turn **OFF** all electrical power to the unit if service is to be performed.
3. Remove the access panel.
4. Move the gas valve switch to the **OFF** position.
5. Replace the access panel.

Failure To Operate

If the unit fails to operate, check the following:

1. Is the thermostat calling for heat?
2. Are access panels securely in place?
3. Is the main disconnect switch closed?
4. Is there a blown fuse?
5. Is the filter dirty or plugged? Dirty or plugged filters will cause the limit control to shut the unit off.
6. Is gas turned on at the meter?
7. Is the manual main shut Off valve open?
8. Is the gas valve turned on?
9. Is the unit ignition system in lock out: If the unit locks out again, inspect the unit for blockages.
10. Is blower harness connected to ignition control? Furnace will not operate unless harness is connected.

Gas Pressure Measurement

Gas Flow (Approximate)

GAS METER CLOCKING CHART				
A97DSMV UNIT	Seconds for One Revolution			
	Natural		LP	
	1 cu ft Dial	2 cu ft Dial	1 cu ft Dial	2 cu ft DIAL
-70	55	110	136	272
-90	41	82	102	204
-110	33	66	82	164
-135	27	54	68	136
Natural-1000 btu/cu ft			LP-2500 btu/cu ft	

Table 24

Furnace should operate at least 5 minutes before checking gas flow. Determine time in seconds for **two** revolutions of gas through the meter. (Two revolutions assures a more accurate time.) **Divide by two** and compare to time in Table 21. If manifold pressure matches Table 24 and rate is incorrect, check gas orifices for proper size and restriction. Remove temporary gas meter if installed.

NOTE: To obtain accurate reading, shut off all other gas appliances connected to meter.

Supply Pressure Measurement

A threaded plug on the inlet side of the gas valve provides access to the supply pressure tap. Remove the threaded plug, install a field provided barbed fitting and connect a manometer to measure supply pressure. Replace the threaded plug after measurements have been taken.

Manifold Pressure Measurement

To correctly measure manifold pressure, the differential pressure between the positive gas manifold and the negative burner box must be considered. Use pressure test adapter kit (available as part 10L3) to assist in measurement.

1. Remove the threaded plug from the outlet side of the gas valve and install a field provided barbed fitting. Connect test gauge "+" connection to barbed fitting to measure manifold pressure.
2. Tee into the gas valve regulator vent hose and connect test gauge "-" connection.
3. Start unit on low heat (40% rate) and allow 5 minutes for unit to reach steady state.
4. While waiting for the unit to stabilize, notice the flame. Flame should be stable and should not lift from burner. Natural gas should burn blue.
5. After allowing unit to stabilize for 5 minutes, record manifold pressure and compare to value given in Table 25.
6. Repeat steps 3, 4 and 5 on HIGH HEAT.

NOTE: Shut unit off and remove manometer as soon as an accurate reading has been obtained. Take care to remove barbed fitting and replace threaded plug.

CAUTION

DO NOT attempt to make adjustments to the gas valve.

Operating Pressure Signal

Operating pressure signal can be taken while the manifold pressure check is taken (using two measuring devices). Or, taken after the manifold pressure measurement is complete.

1. Tee into the negative line between the gas valve and pressure switch and correct to measuring device negative "-".
2. Tee into the positive line between the gas valve and pressure switch and connect to measuring device positive "+".
3. Start unit on low heat (40% rate) and allow 5 minutes for unit to reach steady state.
4. After allowing unit to stabilize for 5 minutes, record operating pressure signal and compare to value given in Table 25.
5. Repeat steps 3 - 4 on high heat.

Proper Combustion

Furnace should operate a minimum of 15 minutes with correct manifold pressure and gas flow rate before checking combustion. Take combustion sample beyond the flue outlet and compare to the tables below. The maximum carbon monoxide reading should not exceed 50 ppm.

High Fire

A97DSMV UNIT	CO ₂ % For Nat.	CO ₂ % For L.P.
070B12	7.6 - 8.6	9.1 - 10.0
090C12		
090C16		
090C20		
110C20		

Table 25

Low Fire

A97DSMV UNIT	CO ₂ % For Nat.	CO ₂ % For L.P.
070B12	5.7	7.2 - 8.2
090C12	5.3 - 6.3	6.8 - 7.8
090C16		
090C20		
110C20		

Table 26

High Altitude Information

NOTE: In Canada, certification for installation at elevations over 4500 feet (1372 m) is the jurisdiction of local authorities.

These units require no manifold pressure adjustments for operation at altitudes up to 7,500 feet (2286 m) above sea level. Table 27 lists conversion kit requirements, pressure switch requirements and manifold pressures at all altitudes.

The combustion air pressure switch is factory set and requires no adjustment.

Conversion Kit Requirements

Model Input Size	LP/Propane Kit	High Altitude Pressure Switch Kit	
	0 - 10,000 (0 - 3048 m)	0 - 7,500 (0 - 2286 m)	7,501 - 10,000 (2287 - 3048m)
070	68W77	Not required	93W75
090			
110			
135			

Table 27



DO NOT attempt to make adjustments to the gas valve.

Manifold and Operating Signal Pressures in inches 0-7500 ft (0-2286 m)

Firing Rate	Manifold Pressure Nat Gas			Manifold Pressure LP/Propane			Operating Pressure Signal (Delta P)		
	Min	Normal	Max	Min	Normal	Max	Min	Normal	Max
40 %	0.5	0.6	0.7	1.3	1.6	1.9	0.25	0.30	0.35
70%	1.7	1.9	2.1	5.1	5.5	5.9	0.60	0.65	0.70
100%	3.2	3.5	3.8	9.5	10.0	10.5	1.10	1.15	1.20

NOTE: The values given in table are measurements only. The gas valve should **NOT** be adjusted.

NOTE: A natural to LP/propane gas changeover kit (Table 27) is necessary to convert this unit. Refer to the changeover kit installation instructions for the conversion procedure.

Table 28

Manifold Pressure Measurement

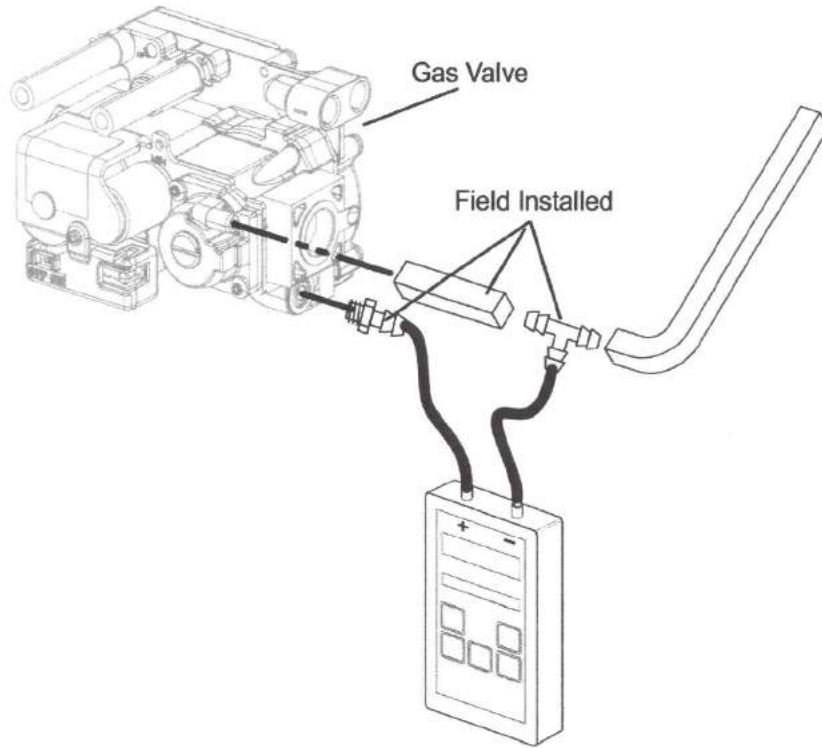

Operation Signal (Delta P) Measurement

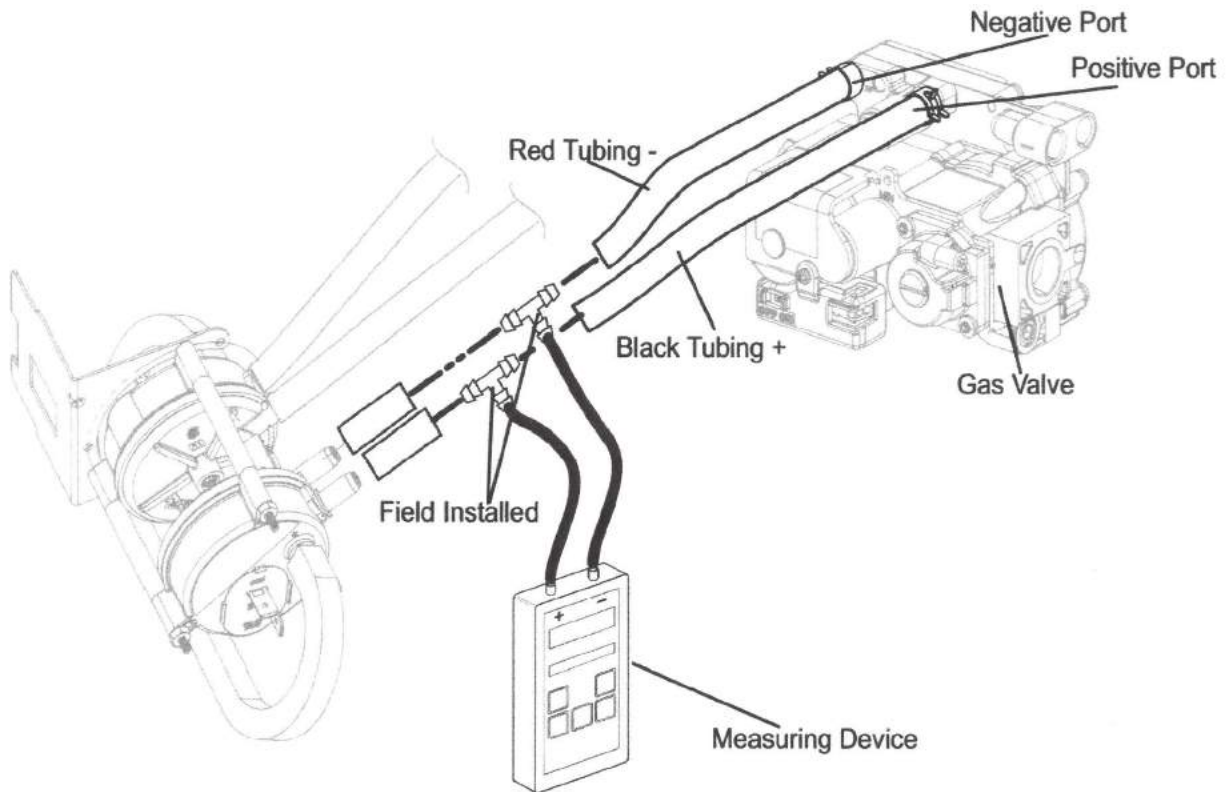

Figure 50

Other Unit Adjustments

Primary Limit

The primary limit is located on the heating compartment vestibule panel. This limit is factory set and requires no adjustment.

Flame Rollout Switches (Two)

These manually reset switches are located on the inside of the burner box. If tripped, check for adequate combustion air before resetting.

Pressure Switches (Two)

The pressure switches are located on the cold end header box. These switches check for proper combustion air inducer operation before allowing ignition trial. The switches are factory set and require no adjustment. Pressure switch tubing installation is critical for safe operation. See Figure below.

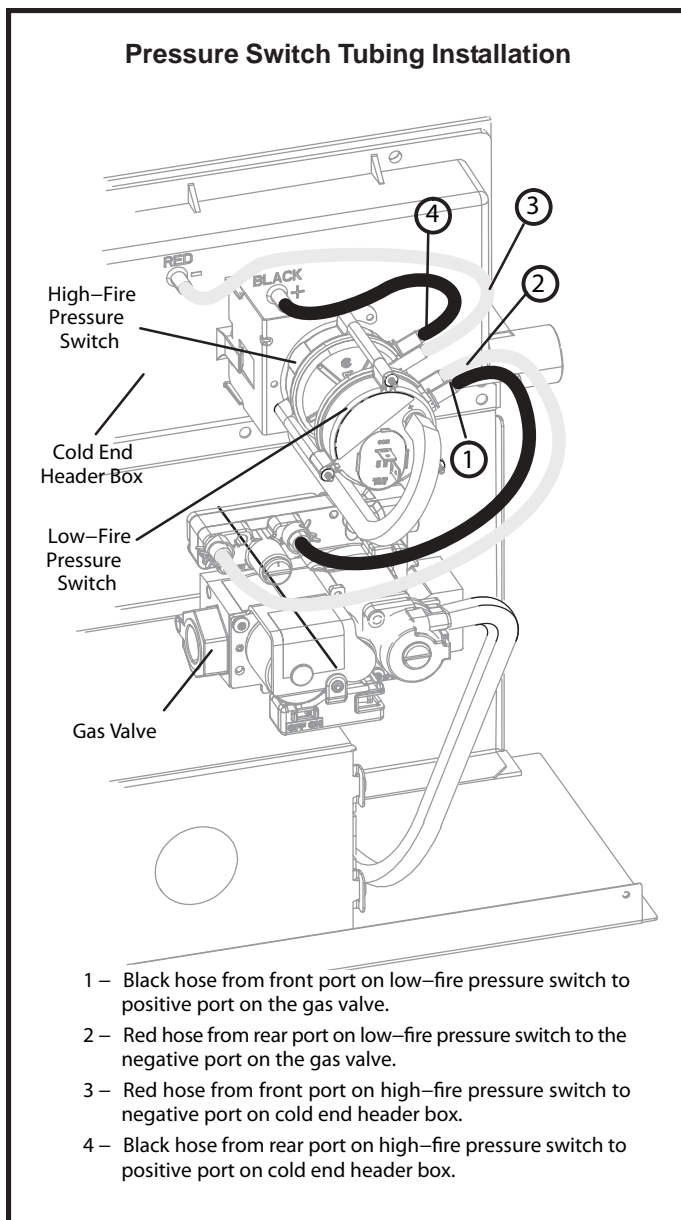

Temperature Rise

After the furnace has been started and supply and return air temperatures have been allowed to stabilize, check the temperature rise with the unit operating at 100 percent firing rate. If necessary, adjust the blower speed to maintain the temperature rise within the range shown on the unit nameplate. Increase the blower speed to decrease the temperature. Decrease the blower speed to increase the temperature. Failure to adjust the temperature rise may cause erratic limit operation.

Thermostat Heat Anticipation

Set the heat anticipator setting (if adjustable) according to the amp draw listed on the wiring diagram that is attached to the unit.

Electronic Ignition

The integrated control has a feature that serves as an automatic reset device for ignition control lockout caused by ignition failure. This type of lockout is usually due to low gas line pressure. After one hour of continuous thermostat demand for heat, the control will break and remake thermostat demand to the furnace and automatically reset the control to begin the ignition sequence.

Exhaust and Air Intake Pipe

1. Check exhaust and air intake connections for tightness and to make sure there is not blockage.
2. Are pressure switches closed? Obstructed exhaust pipe will cause unit to shut off at pressure switches. Check termination for blockages.
3. Reset manual flame rollout switches on burner box cover.

Heating Sequence of Operation

The integrated control initiates a pressure switch calibration at the initial unit start-up on a call for heat. The ignition control will also initiate a calibration any time main power is turned off and back on and a heating demand is present. Additional calibrations may be initiated by the service technician during field test sequence. The following heating sequence of operation assumes completion of a successful calibration.

NOTE: *In Comfort Sync™ communicating applications, the sequence of operation is the same but all DIP switch settings are overridden by the thermostat.*

NOTE: *The thermostat selection DIP switch on the integrated control is factory set in the “TWO STAGE” position.*

Applications Using a Two Stage Thermostat

A-Heating Sequence - Control Thermostat Selection DIP switch in “Two Stage” Position (Factory Settling)

1. On a call for heat, thermostat first stage contacts close sending a signal to the integrated control. The integrated control runs a self diagnostic program and checks high temperature limit switches for normally closed contacts and pressure switches for normally open contacts. The combustion air inducer is energized at ignition speed, which is approximately the same as the inducer speed at 70 percent firing rate.
2. Once the control receives a signal that the low fire pressure switch has closed, the combustion air inducer begins a 15 second prepurge in the ignition speed.
3. After the prepurge is complete, a 20 second initial ignitor warm up period begins. The combustion air inducer continues to operate at the ignition speed.
4. After the 20 second warm up period has ended, the gas valve is energized and ignition occurs. At the same time, the control module sends a signal to begin an indoor blower 30 second ON delay. When the delay ends, the indoor blower motor is energized at a speed that matches the firing rate. After the 10 second ignition stabilization delay expires, the inducer speed is adjusted to the appropriate target rate. The inducer will remain at the 70 percent speed as long as the thermostat has a first stage heating demand.
5. If second stage heat is required, the thermostat second stage heat contacts close and send a signal to the integrated control. The integrated control initiates a 30 second stage recognition delay.

6. At the end of the recognition delay and on all subsequent calls for heat in the same heating cycle, the integrated control energizes the combustion air inducer at high speed. The control also checks the high fire pressure switch to make sure it is closed. As the inducer speed is increased to high, the indoor blower motor is adjusted to a speed which is appropriate for the target rate.
7. When the demand for high fire (second stage) heat is satisfied, the gas valve is de-energized and the field selected indoor blower off delay begins. The combustion air inducer begins a 20 second post purge period.
8. When the combustion air post purge period is complete, the inducer is de-energized. The indoor blower is de-energized at the end of the off delay.

Application Using a Two Stage Thermostat

B - Heating Sequence - Control Thermostat Selection DIP switch in “Variable Capacity” Position

1. On a call for heat, thermostat first stage contacts close sending a signal to the integrated control. The integrated control runs a self diagnostic program and checks high temperature limit switches for normally closed contacts and pressure switches for normally open contacts. The combustion air inducer is energized at ignition speed, which is approximately the same as the inducer speed at 70 percent firing rate.
2. Once the control receives a signal that the low fire pressure switch has closed, the combustion air inducer begins a 15 second prepurge in low speed.
3. After the prepurge is complete, a 20 second initial ignitor warm-up period begins. The combustion air inducer continues to operate at the ignition speed.
4. After the 20 second warm up period has ended, the gas valve is energized and ignition occurs. At the same time, the control module begins an indoor blower 30 second ON delay. When the delay ends, the indoor blower motor is energized at a speed that matches the firing rate. After the 10 second ignition stabilization delay expires, the inducer speed is adjusted to the appropriate target rate. If the furnace is operating in the initial heating cycle after power up, the initial firing rate will be approximately 40 percent. The firing rate on subsequent cycles will be automatically adjusted by the integrated control based on thermostat cycles. The firing rate will vary and will range from 40 percent to 90 percent. The furnace will continue this operation as long as the thermostat has a first stage heating demand.

5. If second-stage heat is required, the thermostat second stage heat contacts close and send a signal to the integrated control. The integrated control either increases the firing rate to 70 percent (if the current rate is at or below 60 percent) or increases the firing rate by 10 percent (if the current rate is above 60 percent). If the call for heat continues 5 minutes beyond this initial upstage, the rate will be increased by 10 percent every 5 minutes until the call for heat is satisfied or the furnace reaches 100 percent rate. As the firing rate increases, the indoor blower motor is adjusted to a speed which is appropriate for the target rate.
 6. If second-stage heat demand is satisfied, but first stage is still present, the furnace will continue to operate at the present firing rate until the heat cycle ends.
 7. When the demand for first and second stage heat is satisfied, the gas valve is de-energized and the fieldselected indoor blower off delay begins. The combustion air inducer begins a 20 second post-purge period.
 8. When the combustion air post purge period is complete, the inducer is de-energized. The indoor blower is de-energized at the end of the off delay.
2. Once the control receives a signal that the low fire pressure switch has closed, the combustion air inducer begins a 15 second prepurge at the ignition speed.
 3. After the prepurge is complete, a 20 second initial ignitor warm up period begins. The combustion air inducer continues to operate at the ignition speed.
 4. After the 20 second warm up period has ended, the gas valve is energized and ignition occurs, which initiates a 10 second ignition stabilization delay. At the same time, the control module sends a signal to begin an indoor blower 30 second **ON** delay. When the delay ends, the indoor blower motor is energized at a speed which is appropriate for the firing rate. After the 10 second ignition stabilization delay expires, the inducer speed is adjusted to 40 percent speed. The integrated control also initiates a second-stage on delay (factory set at 7 minutes; adjustable to 12 minutes).
 5. If the heating demand continues beyond the secondstage on delay, the integrated control energizes the combustion air inducer at 70 percent speed. The indoor blower motor is adjusted to a speed which matches the target rate. A fixed, 10 minute third stage on delay is initiated.
 6. If the heating demand continues beyond the thirdstage on delay, the integrated control energizes the inducer at high speed. The indoor blower motor is adjusted to a speed which is appropriate for the target rate.
 7. When the thermostat heating demand is satisfied, the gas valve is de-energized and the combustion air inducer begins a 20 second post purge. The field selected indoor blower off delay begins.
 8. When the combustion air post purge period is complete, the inducer is de-energized. The indoor blower is de-energized at the end of the off delay.

Applications Using A Single-Stage Thermostat

C - Heating Sequence — Control Thermostat Selection DIP switch in “Single Stage” Position

1. On a call for heat, thermostat first stage contacts close sending a signal to the integrated control. The integrated control runs a self-diagnostic program and checks high temperature limit switches for normally closed contacts and pressure switches for normally open contacts. The combustion air inducer is energized at the ignition speed, which is approximately the same as the inducer speed at 70 percent firing rate.

Service



ELECTRICAL SHOCK, FIRE, OR EXPLOSION HAZARD

Failure to follow safety warnings exactly could result in dangerous operation, serious injury, death or property damage.

Improper servicing could result in dangerous operation, serious injury, death, or property damage.

Before servicing, disconnect all electrical power to furnace.

When servicing controls, label all wires prior to disconnecting. Take care to reconnect wires correctly. Verify proper operation after servicing.

At the beginning of each heating season, system should be checked as follows by a qualified service technician:

Blower

Check the blower wheel for debris and clean if necessary. The blower motors are prelubricated for extended bearing life. No further lubrication is needed.



The blower access panel must be securely in place when the blower and burners are operating. Gas fumes, which could contain carbon monoxide, can be drawn into living space resulting in personal injury or death.

Filters

All filters are installed external to the unit. Filters should be inspected monthly. Clean or replace the filters when necessary to ensure proper furnace operation. Table 3 lists recommended filter sizes.

Exhaust and Air Intake Pipes

Check the exhaust and air intake pipes and all connections for tightness and to make sure there is no blockage.

NOTE: After any heavy snow, ice or frozen fog event the furnace vent pipes may become restricted. Always check the vent system and remove any snow or ice that may be obstructing the plastic intake or exhaust pipes.

Electrical

1. Check all wiring for loose connections.
2. Check for the correct voltage at the furnace (furnace operating). Correct voltage is 120VAC +/-10%.

3. Check amp-draw on the blower motor with the blower access panel in place.

Motor Nameplate _____ **Actual** _____

Winterizing and Condensate Trap Care

1. Turn off power to the unit.
2. Have a shallow pan ready to empty condensate water.
3. Remove the drain cap from the condensate trap and empty water. Inspect the trap then reinstall the drain cap.

Cleaning Heat Exchanger

If cleaning the heat exchanger becomes necessary, follow the below procedures and refer to Figure 1 when disassembling unit. Use papers or protective covering in front of furnace while removing heat exchanger assembly.

1. Turn off electrical and gas supplies to the furnace.
2. Remove the furnace access panels.
3. Disconnect the 2 pin plug from the gas valve.
4. Remove gas supply line connected to gas valve. Remove the burner box cover and remove gas valve manifold assembly.
5. Remove sensor wire from sensor. Disconnect 2 pin plug from the ignitor.
6. Disconnect wires from flame rollout switches.
7. Remove four (4) burner box screws at the vestibule panel and remove burner box. Set burner box assembly aside.

NOTE: If necessary, clean burners at this time. Follow procedures outlined in "Burner Cleaning" section.

8. Loosen the clamps to the flexible exhaust coupling.
9. Disconnect condensate drain line from the cold end header box.
10. Disconnect condensate drain tubing from flue collar. Remove screws that secures the flue collar into place. Remove flue collar. It may be necessary to cut the exiting exhaust pipe for removal of the fitting.
11. Mark and disconnect all combustion air pressure tubing from cold end header collector box.
12. Mark and remove wires from pressure switches. Remove pressure switches. Keep tubing attached to pressure switches.
13. Disconnect the 4 pin plug from the combustion air inducer. Remove two screws which secure combustion air inducer to collector box. Remove combustion air inducer assembly. Remove ground wire from vest panel.
14. Remove electrical junction box from the side of the furnace.
15. Mark and disconnect any remaining wiring to heating compartment components. Disengage strain relief bushing and pull wiring and bushing through the hole in the blower deck.
16. Remove the primary limit from the vestibule panel.
17. Remove two screws from the front cabinet flange at the blower deck. Spread cabinet sides slightly to allow clearance for removal of heat exchanger.

Planned Service

A service technician should check the following items during an annual inspection. Power to the unit must be shut off for the service technician's safety.

Burners - Must be inspected for rust, dirt, or signs of water.

Vent pipe - Must be inspected for signs of water, cracked, damaged or sagging pipe, or disconnected joints.

Unit appearance - Must be inspected for rust, dirt, signs of water, burnt or damaged wires, or components.

Blower access door - Must be properly in place and provide a seal between the return air and the room where the furnace is installed.

Return air duct - Must be properly attached and provide an air seal to the unit.

Operating performance - Unit must be observed during operation to monitor proper performance of the unit and the vent system.

Combustion gases - Flue products must be analyzed and compared to the unit specifications.

Problems detected during the inspection may make it necessary to temporarily shut down the furnace until the items can be repaired or replaced.

Instruct the homeowners to pay attention to their furnace. Situations can arise between annual furnace inspections that may result in unsafe operation.

Integrated Control Diagnostic Codes

Press the diagnostic push button and hold it to cycle through a menu of options. Every five seconds a new menu item will be displayed.

Release the button when the desired mode is displayed.

When a solid "P" is displayed, the furnace capacity/ size is programmed.

When the solid "E" is displayed, the control enters the Error Code Recall mode. Error Code Recall mode menu options: No change (displaying error history) remains in Error Code Recall mode; solid "b" exits Error Code Recall mode; and solid "c" clears the error history. Must press button while flashing "c" is displayed to clear error codes.

When the solid "-" is displayed, the control enters the Field Test mode. Field Test mode menu options: Solid "C" starts pressure switch calibration; blinking "-" exits Field Test mode.

Code	Diagnostic Codes/Status of Equipment	Action Required to Clear and Recover
.	Idle mode (Decimal blinks at 1 Hertz --- 0.5 second ON, 0.5 second OFF).	
A	Cubic feet per minute (cfm) setting for indoor blower (1 second ON, 0.5 second OFF) / cfm setting for current mode displayed.	
C	Cooling stage (1 second ON, 0.5 second OFF) / 1 or 2 displayed / Pause / cfm setting displayed / Pause / Repeat codes).	
d	Dehumidification mode (1 second ON) / 1 second OFF) / cfm setting displayed / Pause / Repeat Codes).	
h	Variable Capacity Heat (1 second ON, 0.5 second OFF) / % of input rate displayed / Pause/ cfm setting / Pause/ Repeat codes.	
H	Heat Stage (1 second ON, 0.5 second OFF) / 1 or 2 displayed / Pause / cfm setting displayed / Pause / Repeat codes.	
df	Defrost mode.	
E 105	Device communication problem – No other devices on BUS (Communication system).	Equipment is unable to communicate. Check for mis wire and loose connections and check for a high voltage source of noise close to the system. (welder etc.).
E 110	Low line voltage.	Line Voltage low (Voltage lower than nameplate rating) Check voltage.
E 113	High line voltage.	Line Voltage High (Voltage higher than nameplate rating) Check voltage.
E 114	Line voltage frequency out-of-range.	No 60 hertz power (Check voltage and frequency).
E 115	Low 24V – Control will restart if the error recovers.	24 voltage low (Range is 18 to 30 volts) Check voltage.
E 120	Unresponsive device.	Usually caused by delay in outdoor unit responding to indoor unit polling recycle power, check wiring.
E 124	Active communicating thermostat signal missing for more than 3 minutes.	Equipment lost communication with the thermostat. Check connections and cycle power on the thermostat.
E 125	Control failed self-check, internal error, failed hardware. Will restart if error recovers. Integrated furnace control not communicating. Covers hardware errors (flame sense circuit faults, pin shorts, etc.).	Hardware problem on the control board. Cycle power on control. Replace if problem prevents service and is persistent.
E 126	Failed internal control communication between microcontrollers.	Hardware problem on the control board. Cycle power on control. Replace if problem prevents service and is persistent.
E 131	Corrupted control parameters (Verify configuration of system).	Reconfigure the system. Replace board if service (heating /cooling) is unavailable.
E 180	Outdoor air sensor failure – NO error if disconnected. Only shown if shorted or out-of-range.	Compare outdoor sensor resistance to temperature resistance charts in installation instructions. Replace if necessary.
E 200	Hard lockout – Rollout circuit open or previously open.	Correct unit cause of rollout trip or replace flame rollout switch and test furnace operation.
E 201	Indoor blower communication failure – Unable to communicate with blower motor.	Indoor blower communication failure including power outage.
E 202	Indoor blower motor mis-match – Indoor motor horsepower does not match unit capacity.	Incorrect furnace size code selected. Check unit size codes on configuration guide or in installation instructions.
E 203	Appliance capacity / size is NOT programmed. Invalid unit codes refer to configuration flow chart in installation instructions.	No furnace size code selected. Check unit size codes on configuration guide or in installation instructions.
E 204	Gas valve mis-wired.	Check operation of gas valve.
E 205	Gas valve control relay contact shorted.	Check operation of gas valve.
E 207	Hot surface ignitor sensed open – Refer to troubleshooting in installation instruction.	Measure resistance of Hot Surface Ignitor, replace if open or not within specification.

Integrated Control Diagnostic Codes (continued)

Code	Diagnostic Codes/Status of Equipment	Action Required to Clear and Recover
E 223	Low pressure switch failed open – Refer to troubleshooting in installation instruction.	Check inches of water column pressure during operation of low pressure switch on heat call, measure inches of water column of operating pressure, inspect vent and combustion air inducer for correct operation and restriction.
E 224	Low pressure switch failed closed – Refer to troubleshooting in installation instruction.	Check low pressure switch for closed contacts, measure inches of water column of operating pressure, inspect vent and combustion air inducer for correct operation and restriction.
E 225	High pressure switch failed open – Refer to troubleshooting in installation instruction.	Check inches of water column pressure of high pressure switch on heat call, measure inches of water column of operating pressure, inspect vent and combustion air inducer for correct operation and restriction.
E 226	High pressure switch failed closed – Refer to troubleshooting in installation instruction.	Check high pressure switch for closed contacts, measure inches of water column of operating pressure, inspect vent and combustion air inducer for correct operation and restriction.
E 227	Low pressure switch open during trial for ignition or run mode. Refer to troubleshooting in installation instruction.	Check inches of water column pressure during operation of low pressure switch on heat call, measure inches of water column of operating pressure, inspect vent and combustion air inducer for correct operation and restriction.
E 228	Unable to perform successful pressure switch calibration.	Retry after 300 seconds. Error counter cleared when exiting lockout, unable to perform pressure switch calibration. Check vent system and pressure switch wiring connections.
E 240	Low flame current – Run mode – Refer to troubleshooting in installation instruction.	Check micro amperes of flame sensor, clean or replace sensor. Measure voltage of neutral to ground for good unit ground.
E 241	Flame sensed out of sequence – Flame still present.	Shut off gas, check for gas valve leak.
E 250	Limit switch circuit open – Refer to troubleshooting in installation instruction.	Check why limit is tripping, overfired, low air flow.
E 252	Discharge air temperature too high (gas heat only).	Check temperature rise, air flow and input rate.
E 270	Soft lockout – Exceeded maximum number of retries. No flame current sensed.	Check for gas flow, ignitor lighting burner, flame sensor current.
E 271	Soft lockout – Exceeded maximum number of retries. Last retry failed due to the pressure switch opening.	See E 223.
E 272	Soft lockout – Exceeded maximum number of recycles. Last recycle due to the pressure switch opening.	See E 223 and E 225.
E 273	Soft lockout – Exceeded maximum number of recycles. Last recycle due to flame failure.	See E 240.
E 274	Soft lockout – Exceeded maximum number of recycles. Last recycle failed due to the limit circuit opening or limit remained open longer than 3 minutes.	See E 250.
E 275	Soft lockout – Flame sensed out of sequence from code 241 fault. Flame signal is gone.	See E 241.
E 276	Soft lockout – Exceeded maximum number of calibration retries.	See E 228.
E 290	Ignitor circuit fault – Failed ignitor or triggering circuitry.	See E 207.
E 291	Restricted air flow – Cubic feet per minute is lower than what is needed for minimum firing rate.	Check for dirty filter, unit air flow restriction, blower performance.
E 292	Indoor blower motor unable to start – Seized bearings, stuck wheel, etc.	Indoor blower motor unable to start (seized bearing, stuck wheel, etc), replace motor or wheel if assembly does not operate or meet performance.
E 294	Combustion air inducer motor amp draw is too high.	Check combustion blower bearings, wiring, amperes, replace if it does not operate or meet performance.

Integrated Control Diagnostic Codes (continued)

Code	Diagnostic Codes/Status of Equipment	Action Required to Clear and Recover
E 295	Indoor blower motor temperature is too high.	Indoor blower motor over temperature (motor tripped on internal protector), Check motor bearings, amperes. Replace if necessary.
E 310	Discharge error sensor failure – No error if disconnected. Only shown if shorted or out-of-range.	Discharge air temperature(DATS) out of range, code is activated during "Field test mode".
E 311	Heat rate reduced to match indoor blower air flow. Replace filter or repair duct restriction.	Furnace blower in cutback mode due to restricted airflow. Check filter and ductwork. To clear replace filter if needed or repair/ add ductwork.
E 312	Restricted air flow in cooling or continuous fan mode is lower than cfm setting.	Restricted airflow – Indoor blower is running at a reduced cubic feet per minute (Cutback Mode) – The variable speed motor has pre-set speed and torque limiters to protect the motor from damage caused by operating out of its designed parameters (0 to 0.8 inches water column total external static pressure). Check filter and ductwork. To clear replace filter if needed or repair/ add ductwork.
E 313	Indoor or outdoor unit capacity mismatch.	Incorrect Indoor /outdoor capacity code selected. Check for proper configuration in installation instructions. Alarm is just a warning. The system operation is not impacted at all and alarm would clear when Commissioning is exited.
E 331	Global network connection – Communication link problem.	For Future Use.
E 347	No 24 Volt output on Y1 to C with non-communicating outdoor unit.	Y1 relay / Stage 1 failed (Pilot relay contacts did not close or the relay coil did not energize).
E 348	No 24 Volt output on Y2 to C with non-communicating outdoor unit.	Y2 relay / Stage 2 failed (Pilot relay contacts did not close or the relay coil did not energize).
E 349	No 24 Volts between R & O with non-communicating outdoor unit (Dual fuel module required for heat pump application).	Configuration link R to O needs to be cut on control board.
E 401	LSOM – Compressor ran more than 18 hours in air conditioning mode.	Compressor protector is open. Check for high head pressure, check compressor supply voltage. Outdoor unit power disconnect is open, compressor circuit breaker or fuse(s) is open, broken wire or connector is not making contact. Low or high pressure switch open if present in the system. Compressor contactor has failed to close.
E 402	LSOM – Outdoor unit system pressure trip.	Compressor ran over 18 hours in air conditioning mode.
E 403	LSOM – Compressor short-cycling (Running less than 4 minutes).	Outdoor unit pressure trip. Check dirty coil, fan motor, refrigerant charge.
E 404	LSOM – Compressor rotor locked.	Compressor short cycling (Running less than 4 minutes).
E 405	LSOM – Compressor open circuit.	Check capacitor, wiring, hard start kit, replace compressor.
E 406	LSOM – Compressor open start circuit.	Check compressor for hot (cool down), check pressures, fan motor etc. Replace compressor if unable to get circuit to close and compressor to operate.
E 407	LSOM – Compressor open run circuit.	
E 408	LSOM – Compressor contactor is welded.	
E 409	LSOM – Compressor low voltage.	Replace contactor.

Configuring Unit Size Codes

Power-Up – Number displayed represents by integrated control unit size code (furnace model and capacity). If three horizontal bars are displayed followed by continuous E203, furnace control does not recognize unit size code. Configure per the following:



Furnace control in IDLE mode
No heating, cooling or indoor fan operation)

Yes

No

To enter Field Test Mode: push and hold button next to 7-segment LED display until solid dash symbol appears. Release button.



If alarm is present, furnace control will display error code. If alarm is not present solid dash starts blinking on 7-segment LED display.



Push and hold button until the solid P symbol is displayed on the 7-segment LED. Release button. This mode allows the user to select a unit size code number that matches the furnace model size and capacity.
IMPORTANT : Field replacement controls may need to be manually configured to validate furnace unit size code.



Solid P starts blinking on 7-Segment LED

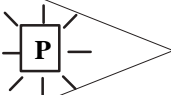

Push and hold button. Integrated control will display unit size code number for each furnace model for five seconds.

Turn room thermostat to OFF

UNIT SIZE CODE	FURNACE MODEL
H	SLP98DFXV-070-36B
J	SLP98DFXV-090-36C
L	SLP98DFXV-090-48C
n	SLP98DFXV-090-60C
o	SLP98DFXV-110-60C

When the correct unit size code is displayed, release button. Selected code will flash for 10-second period. During that period, hold push button until code stops blinking (disappear for 2 seconds). Integrated control will store code in memory and will automatically exit Field Test Mode and reset. (If second period expires or push button is held less than five seconds, control will automatically exit Field Test Mode and go into IDLE mode without storing unit size code. If this happens, programming function must be repeated).

Verify that the selected unit size code is correct and stored in non-volatile memory by cycling the 24 volt power to the furnace control. (At 24 volt power-up of the furnace control, the 7-segment LED will display a unit size code. If three horizontal bars display, board does not recognize unit size code. Programming function must be repeated)



FINISHED

Troubleshooting: Heating Sequence of Operation

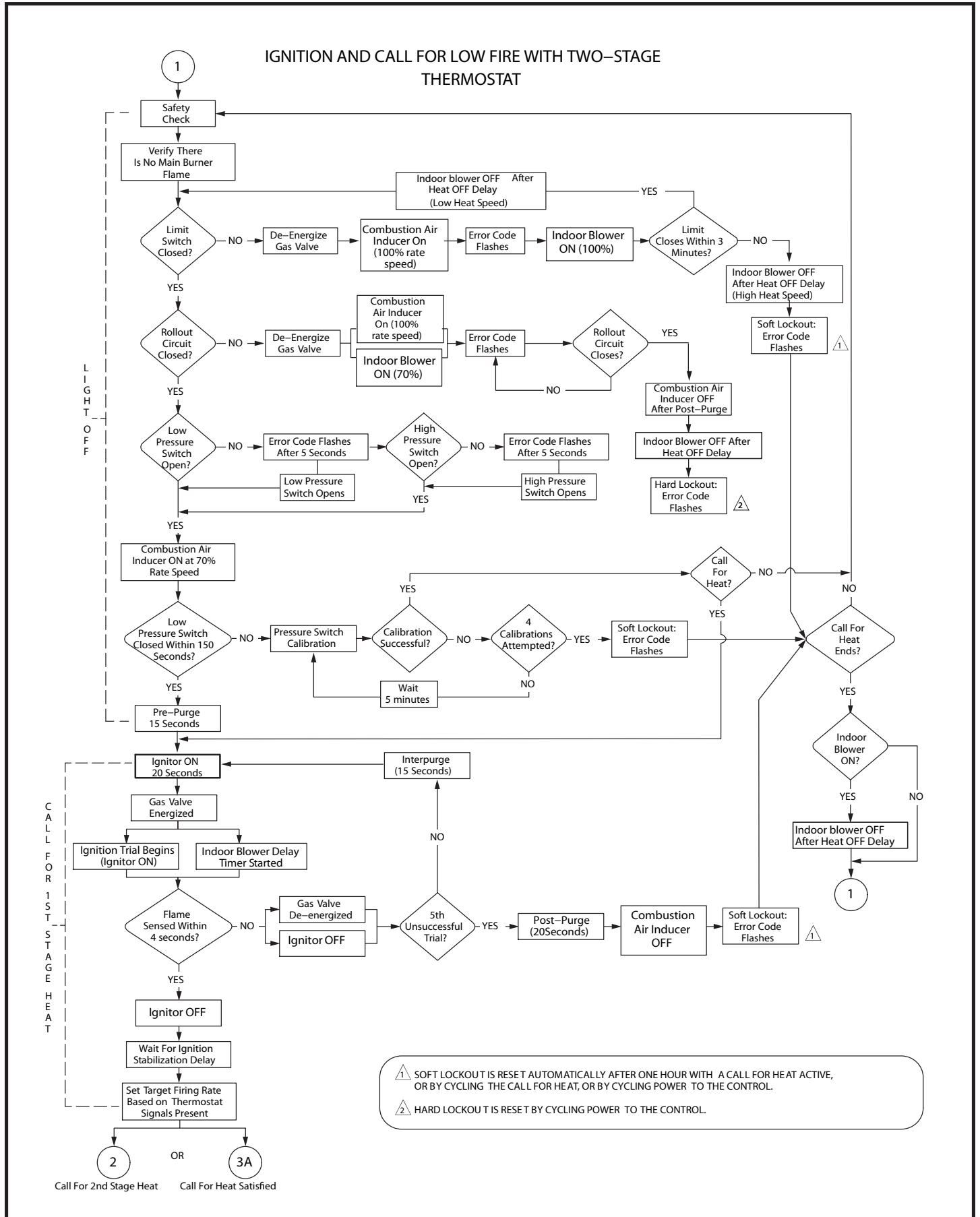

Troubleshooting: Heating Sequence of Operation (continued)

CALL FOR HIGH FIRE WITH TWO-STAGE THERMOSTAT

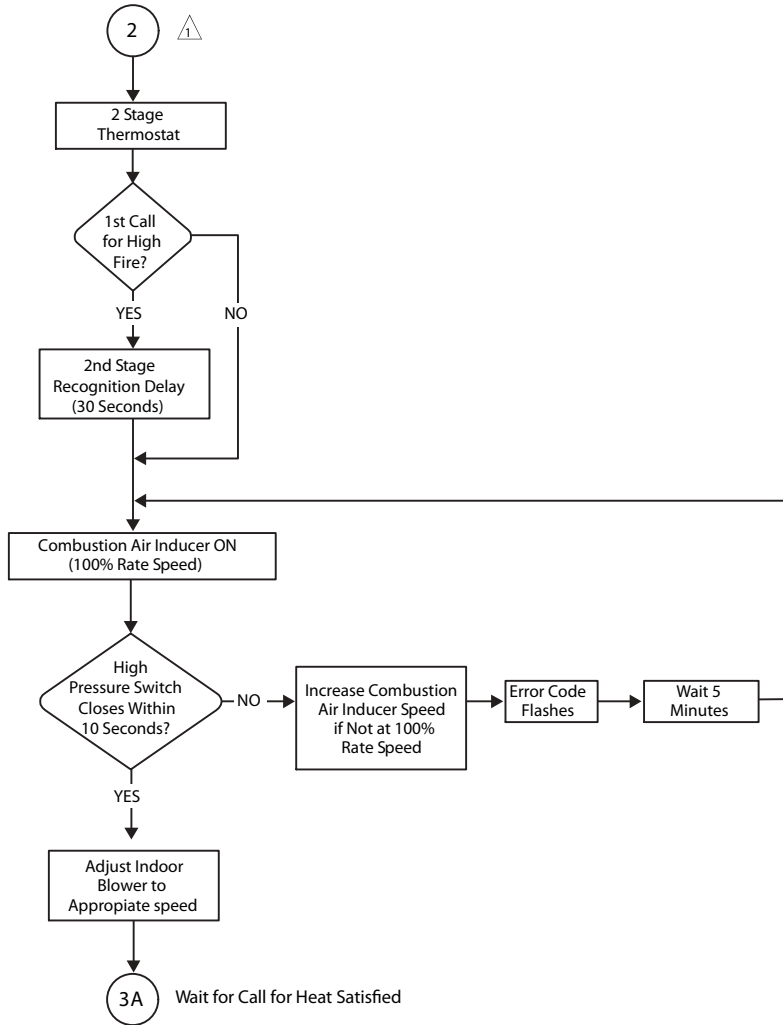

- ⚠ System will always light at 70% even if 2nd stage call for heat is in place
- ⚠ If the high pressure switch does not close within 5 attempts, the system will operate at low fire for the remainder of the call for heat at request

Troubleshooting: Heating Sequence of Operation (continued)

CALL FOR HEAT SATISFIED

RUN MODE (TWO-STAGE THERMOSTAT)
 FIRST OR SECOND-STAGE CALL FOR HEAT
 ALL INPUTS MONITORED (LIMIT, PRESSURE,
 CALL FOR HEAT/COOL, FLAME LEVEL).

RUN MODE (SINGLE-STAGE THERMOSTAT)
 ALL INPUTS MONITORED (LIMIT, PRESSURE,
 CALL FOR HEAT/COOL, FLAME LEVEL).

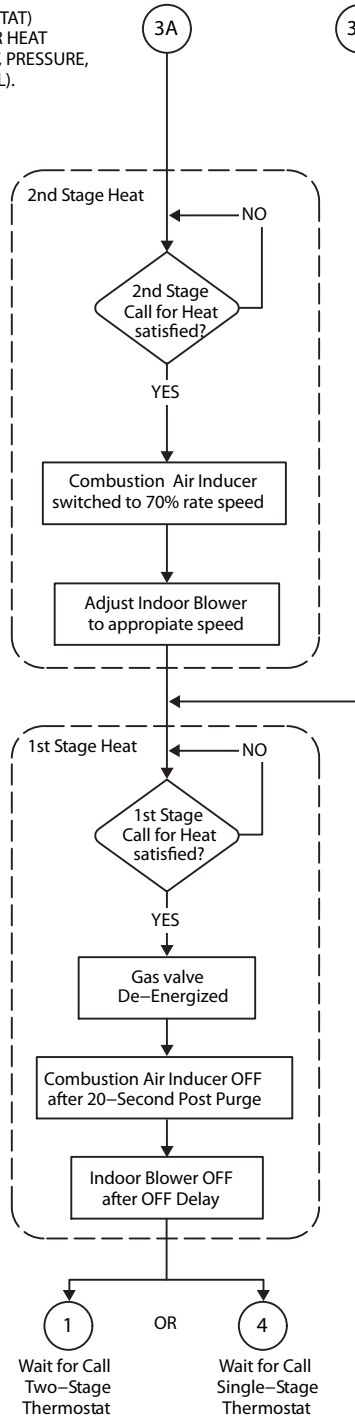

Troubleshooting: Heating Sequence of Operation (continued)

IGNITION AND CALL FOR HEAT WITH SINGLE-STAGE THERMOSTAT

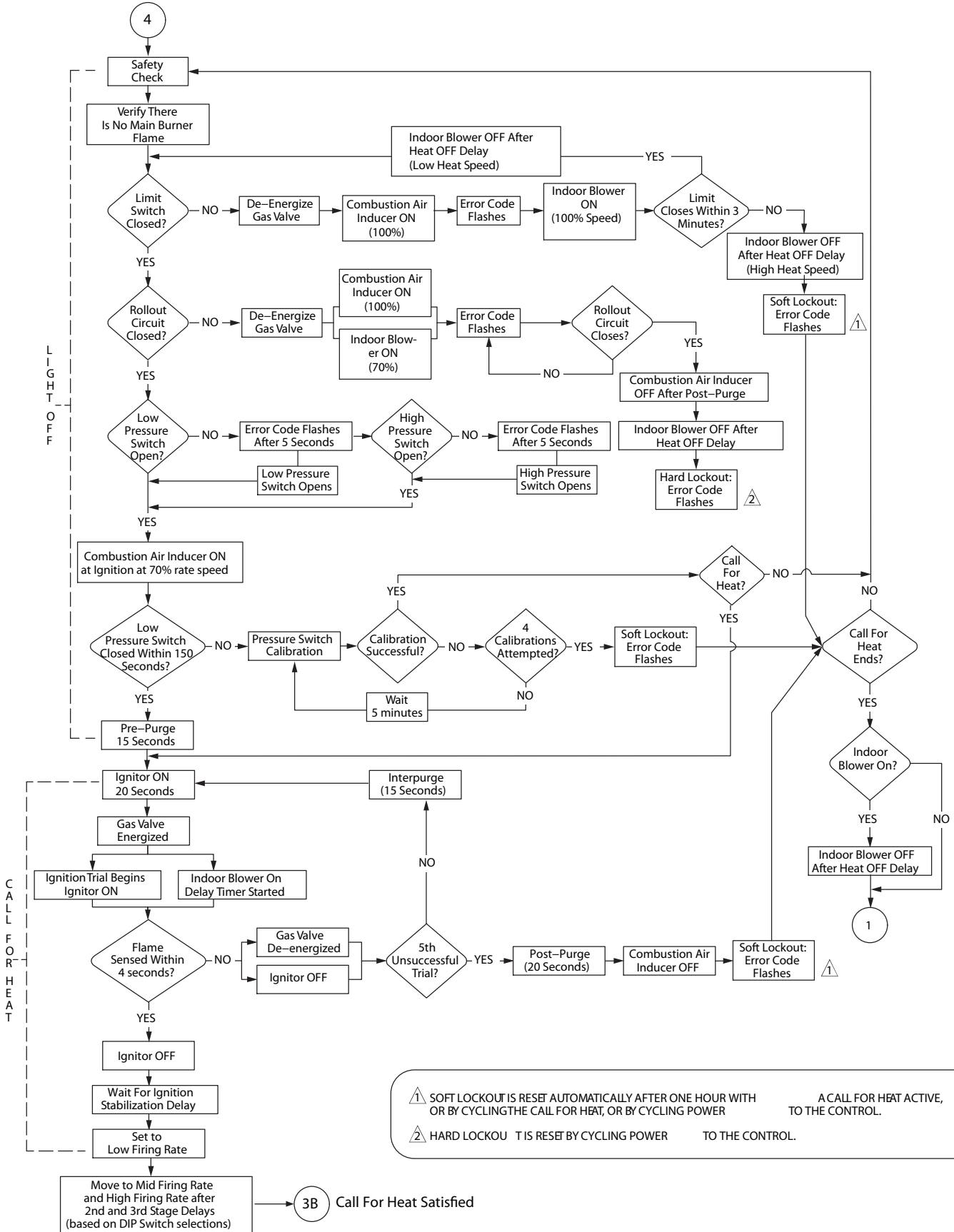

Troubleshooting: Cooling Sequence of Operation

CALL FOR COOLING

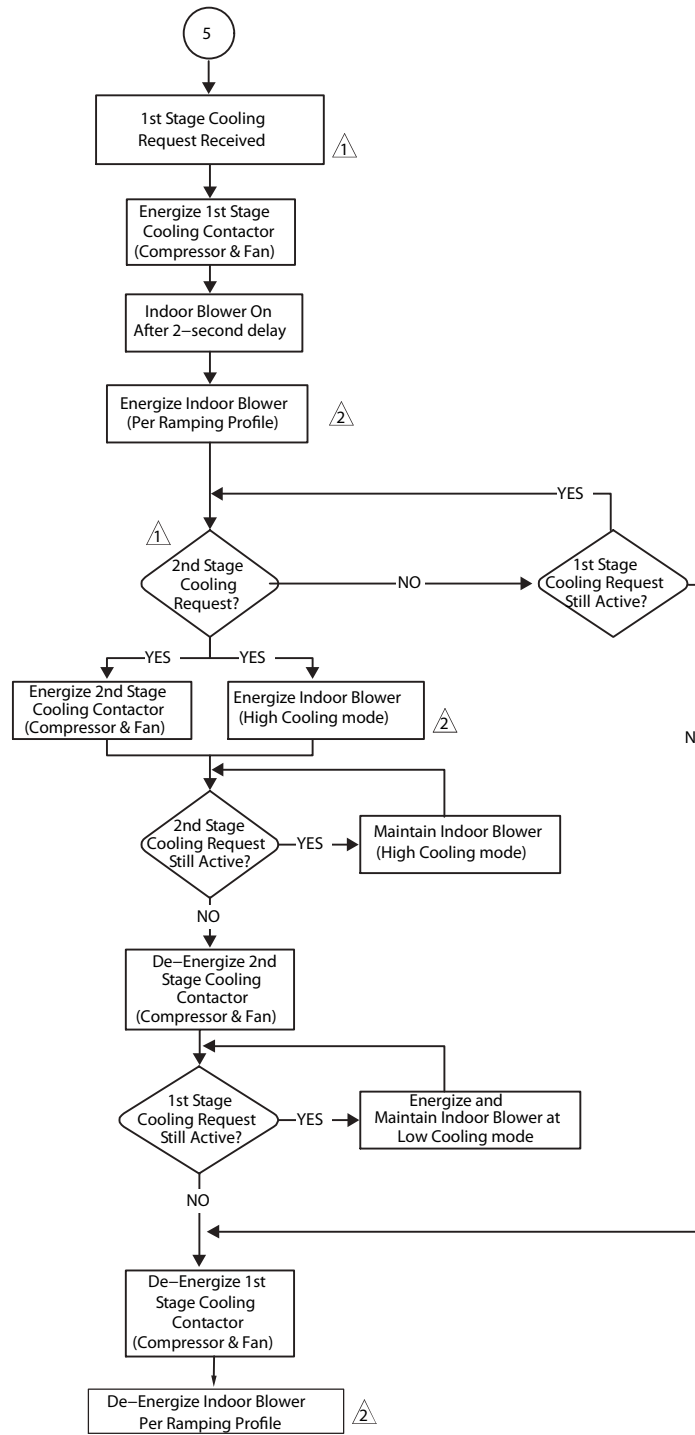

⚠ 2nd stage cooling operation requires a 2-stage thermostat, a 2-stage cooling system and on-board link W915 must be cut. The control will not respond to a 2nd stage cooling request unless a 1st stage cooling request is active

⚠ Indoor blower cooling mode and high cooling mode have a specific ON, OFF and speed ramping profiles. The specific profile is selected using the DIP switches on the control.

Troubleshooting: Continuous Fan Sequence of Operation

CONTINUOUS LOW SPEED INDOOR BLOWER SEQUENCE OF OPERATION

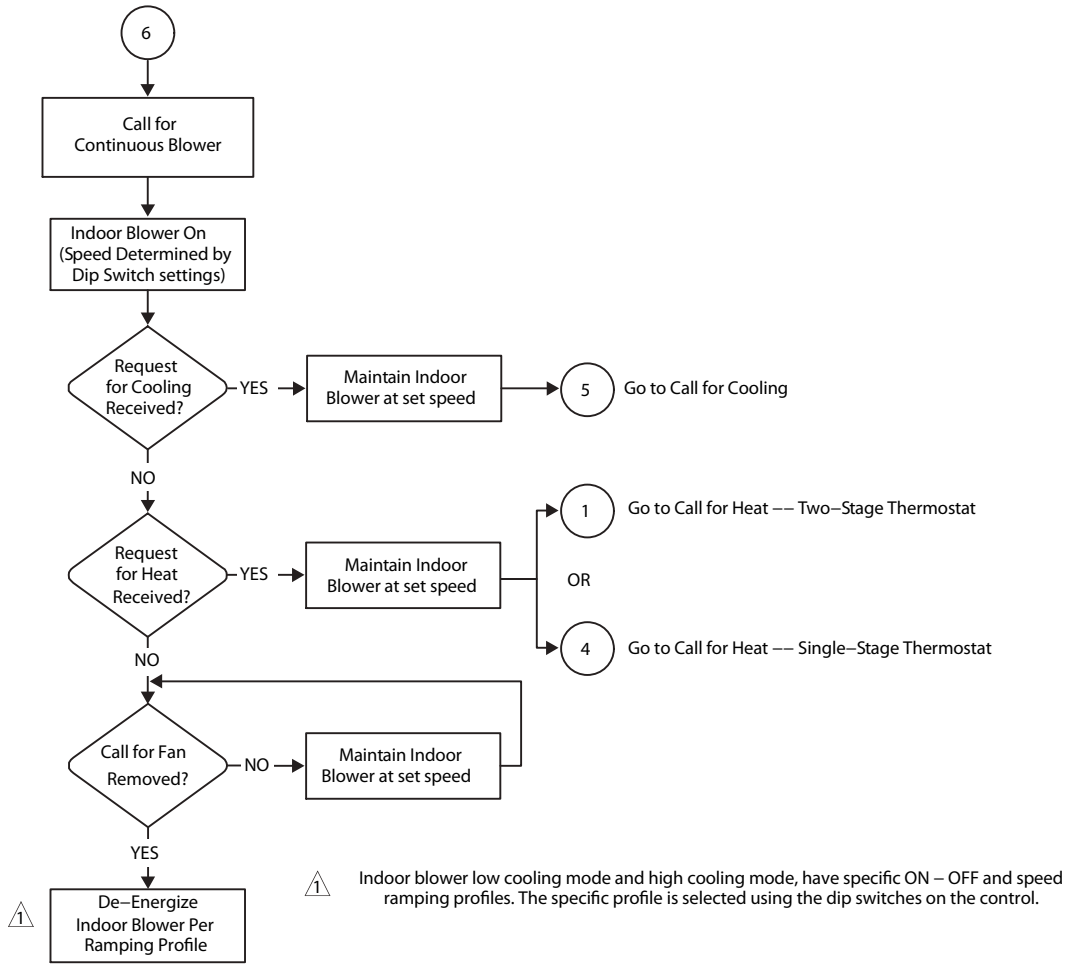

REPAIR PARTS LIST

The following repair parts are available through Allied Air distributors. When ordering parts, include the complete furnace model number listed on the nameplate. **All service must be performed by a licensed professional installer (or equivalent), service agency, or gas supplier.**

Cabinet Parts

- Heating Compartment Access Panel
- Blower Access Panel
- Top Cap

Control Panel Parts

- Transformer
- Integrated Control Board
- Door Interlock Switch
- Circuit Breaker

Blower Parts

- Blower Wheel
- Motor
- Motor Mounting Frame
- Blower Housing Cut Off Plate
- Power Choke (1 HP only)

Heating Parts

- Flame Sensor
- Heat Exchanger Assembly
- Gas Manifold
- Combustion Air Inducer
- Gas Valve
- Main Burner Cluster
- Main Burner Orifices
- Pressure Switch
- Ignitor
- Primary Limit Control
- Flame Rollout Switches

REQUIREMENTS for COMMONWEALTH of MASSACHUSETTS

Modifications to NFPA-54, Chapter 10

Revise NFPA-54 section 10.8.3 to add the following requirements:

For all side wall, horizontally vented, gas-fueled equipment installed in every dwelling, building or structure used in whole or in part for residential purposes, including those owned or operated by the Commonwealth and where the side wall exhaust vent termination is less than seven (7) feet above the finished grade in the area of the venting, including but not limited to decks and porches, the following requirements shall be satisfied:

1. **INSTALLATION OF CARBON MONOXIDE DETECTORS.** At the time of installation of the side wall, horizontally vented, gas-fueled equipment, the installing plumber or gas fitter shall observe that a hard-wired carbon monoxide detector with an alarm and battery backup is installed on the floor level where the gas equipment is to be installed. In addition, the installing plumber or gas fitter shall observe that a battery-operated or hard-wired carbon monoxide detector with an alarm is installed on each additional level of the dwelling, building or structure served by the side wall, horizontally vented, gas-fueled equipment. It shall be the responsibility of the property owner to secure the services of qualified licensed professionals for the installation of hard-wired carbon monoxide detectors.
 - a. In the event that the side wall, horizontally vented, gas-fueled equipment is installed in a crawl space or an attic, the hard-wired carbon monoxide detector with alarm and battery backup may be installed on the next adjacent floor level.
 - b. In the event that the requirements of this subdivision cannot be met at the time of completion of installation, the owner shall have a period of thirty (30) days to comply with the above requirements; provided, however, that during said thirty (30) day period, a battery-operated carbon monoxide detector with an alarm shall be installed.
2. **APPROVED CARBON MONOXIDE DETECTORS.** Each carbon monoxide detector as required in accordance with the above provisions shall comply with NFPA 720 and be ANSI/UL 2034 listed and IAS certified.
3. **SIGNAGE.** A metal or plastic identification plate shall be permanently mounted to the exterior of the building at a minimum height of eight (8) feet above grade directly in line with the exhaust vent terminal for the horizontally vented, gas-fueled heating appliance or equipment. The sign shall read, in print size no less than one-half (1/2) inch in size, "**GAS VENT DIRECTLY BELOW. KEEP CLEAR OF ALL OBSTRUCTIONS.**"

4. **INSPECTION.** The state or local gas inspector of the side wall, horizontally vented, gas-fueled equipment shall not approve the installation unless, upon inspection, the inspector observes carbon monoxide detectors and signage installed in accordance with the provisions of 248 CMR 5.08(2)(a) 1 through 4.

EXEMPTIONS: The following equipment is exempt from 24 CMR 5.08(2)(a) 1 through 4:

1. The equipment listed in Chapter 10 entitled "Equipment Not Required to Be Vented" in the most current edition of NFPA 54 as adopted by the Board; and
2. Product Approved side wall, horizontally vented, gas-fueled equipment installed in a room or structure separate from the dwelling, building or structure used in whole or in part for residential purposes.

MANUFACTURER REQUIREMENTS - GAS EQUIPMENT VENTING SYSTEM PROVIDED.

When the manufacturer of Product Approved side wall, horizontally vented, gas-fueled equipment provides a venting system design or venting system components with the equipment, the instructions provided by the manufacturer for installation of the equipment and the venting system shall include:

1. Detailed instructions for the installation of the venting system design or the venting system components: and
2. A complete parts list for the venting system design or venting system.

MANUFACTURER REQUIREMENTS - GAS EQUIPMENT VENTING SYSTEM NOT PROVIDED.

When the manufacturer of Product Approved sidewall, horizontally vented, gas-fueled equipment does not provide the parts for venting the flue gases, but identifies "special venting systems," the following requirements shall be satisfied by the manufacturer:

1. The referenced "special venting system" instructions shall be included with the appliance or equipment installation instructions; and
2. The "special venting systems" shall be Product Approved by the Board, and the instructions for that system shall include a parts list and detailed installation instructions.

A copy of all installation instructions for all Product Approved side wall, horizontally vented, gas-fueled equipment, all venting instructions, all parts lists for venting instructions, and/or all venting design instructions shall remain with the appliance or equipment at the completion of the installation.