

# INSTALLATION INSTRUCTIONS

## A80DS2V

### Warm Air Gas Furnace Variable Speed Downflow Air Discharge



*This manual must be left with the homeowner for future reference.*



This is a safety alert symbol and should never be ignored. When you see this symbol on labels or in manuals, be alert to the potential for personal injury or death.

#### CAUTION

As with any mechanical equipment, personal injury can result from contact with sharp sheet metal edges. Be careful when you handle this equipment.

#### WARNING

Improper installation, adjustment, alteration, service or maintenance can cause property damage, personal injury or loss of life. Installation and service must be performed by a licensed professional installer (or equivalent), service agency or the gas supplier.

#### NOTICE

A thermostat is not included and must be ordered separately.

- A Comfort Sync™ thermostat must be used in communicating applications.
- In non-communicating applications, a traditional non-communication thermostat may be used.

In all cases, setup is critical to ensure proper system operation.

Field wiring for both communicating and non-communicating applications is illustrated in these instructions.

#### TABLE OF CONTENTS

Unit Dimensions .....	2	System Wiring .....	24
A80DS2V Parts Arrangement .....	3	Wiring Diagram .....	30
A80DS2V Gas Furnace .....	4	Integrated Control Board .....	32
Shipping and Packing List .....	4	Blower Data .....	38
Safety Information .....	4	Unit Start-Up .....	40
Use of Furnace as a Construction Heater .....	5	Gas Pressure Adjustment .....	41
General .....	6	Proper Combustion .....	41
Combustion, Dilution, Ventilation Air .....	6	High Altitude .....	42
Setting Equipment .....	10	Other Unit Adjustments .....	43
Filters .....	11	Heating Sequence of Operation .....	43
Duct System .....	11	Service .....	45
Venting .....	12	Planned Service .....	48
Gas Piping .....	19	Repair Parts List .....	48
Electrical .....	21	Diagnostic Codes .....	49
Thermostat .....	22		



(P) 506892-01

Manufactured By  
**Allied Air Enterprises LLC**  
**A Lennox International, Inc. Company**  
215 Metropolitan Drive  
West Columbia, SC 29170

A80DS2V Unit Dimensions - inches (mm)

TOP VIEW

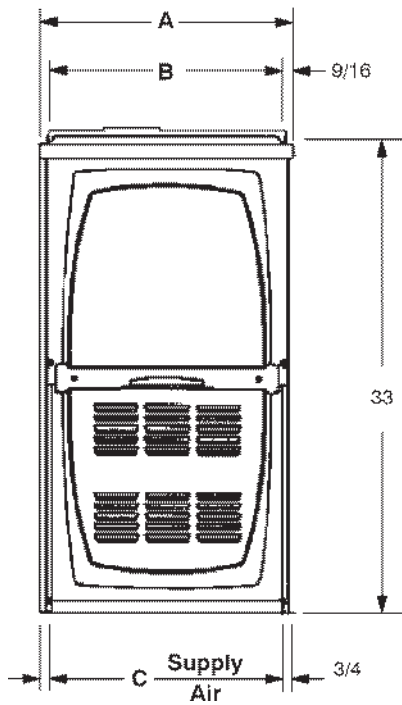
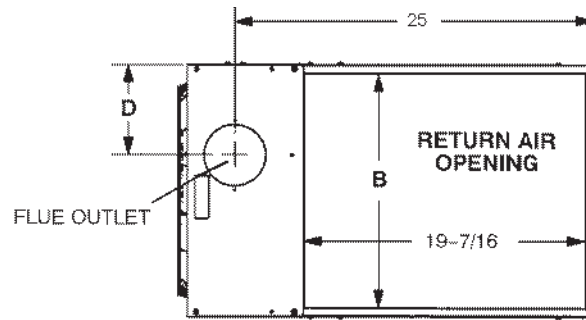

FRONT VIEW

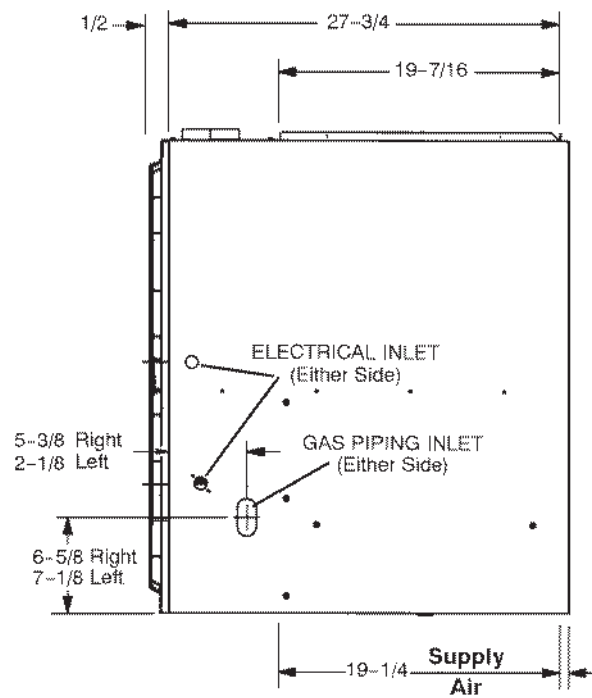

SIDE VIEW

Model	A		B		C		D	
	in.	mm	in.	mm	in.	mm	in.	mm
<b>A80DS2V</b>								
070-12	14-1/2	368	13-3/8	340	13	330	4-3/4	121
090-16	17-1/2	446	16-3/8	416	16	406	6-1/4	159
110-20	21	533	19-7/8	504	19-1/2	495	8	203

EXPANDED VIEW

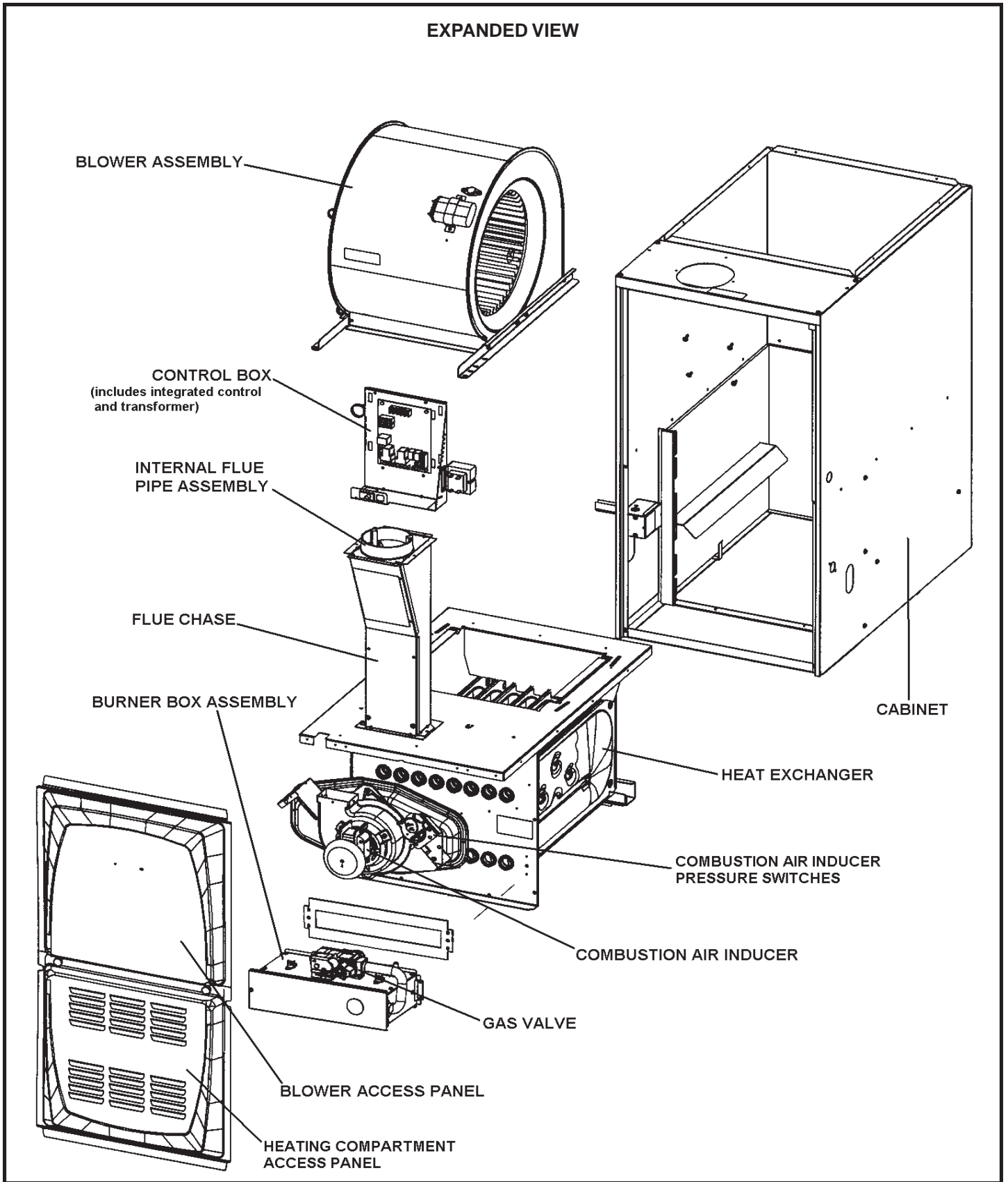

Figure 1

## A80DS2V Gas Furnace

The A80DS2V gas furnace is shipped with a two stage, variable speed control. The control is compatible with:

- Comfort Sync™ communicating thermostats
- Conventional non-communicating thermostats

Each unit is shipped ready for installation in the downflow position.

The furnace is equipped for installation in natural gas applications. A conversion kit (ordered separately) is required for use in LP/propane gas applications.

## Shipping and Packing List

- 1 - Assembled Gas Furnace
- 1 - Bag assembly containing the following:
  - 2 - Screws
  - 1 - Snap bushing
  - 1 - Snap Plug
  - 1 - Wire tie
  - 1 - Vent warning label
  - 1 - Owner's manual and warranty card

Check equipment for shipping damage. If you find any damage, immediately contact the last carrier.

Please refer to specification sheets for available accessories.

## Safety Information



### DANGER OF EXPLOSION!

There are circumstances in which odorant used with LP/Propane gas can lose its scent. In case of a leak, LP/Propane gas will settle close to the floor and may be difficult to smell. An LP/Propane leak detector should be installed in all LP applications.



Improper installation, adjustment, alteration, service or maintenance can cause property damage, personal injury or loss of life. Installation and service must be performed by a licensed professional installer (or equivalent), service agency or the gas supplier.



As with any mechanical equipment, personal injury can result from contact with sharp sheet metal edges. Be careful when you handle this equipment.

## Certifications

These units are CSA International certified to ANSI Z21.47.

In the USA, installation of gas furnaces must conform with local building codes. In the absence of local codes, units must be installed according to the current National Fuel Gas Code (ANSI-Z223.1). The National Fuel Gas Code is available from the following address: **American National Standards Institute, Inc., 11 West 42nd Street, New York, NY 10036.**

## Clearances

Adequate clearance must be made around the air openings into the vestibule area. In order to ensure proper unit operation, combustion and ventilation air supply must be provided according to the current National Fuel Gas Code. Vent installations must be consistent with the venting tables (in this instruction) and applicable provisions of local building codes.

This furnace is CSA International certified for installation clearances to combustible material as listed on the unit nameplate and in Figure 14. Accessibility and service clearances must take precedence over fire protection clearances.

**NOTE:** *For installation on combustible floors, the furnace shall not be installed directly on carpeting, tile, or other combustible material other than wood flooring.*

## Installed Locations

For installation in a residential garage, the furnace must be installed so that the burner(s) and the ignition source are located no less than 18 inches (457 mm) above the floor. The furnace must be located or protected to avoid physical damage by vehicles. When a furnace is installed in a public garage, hangar, or other building that has a hazardous atmosphere, the furnace must be installed according to recommended good practice requirements and current National Fuel Gas Code.

**NOTE:** *Furnace must be adjusted to obtain a temperature rise (high and low fire) within the range(s) specified on the unit nameplate. Failure to do so may cause erratic limit operation and may also result in premature heat exchanger failure.*

This furnace must be installed so that its electrical components are protected from water.

### Installed in Combination with a Cooling Coil

When this furnace is used with cooling units, it shall be installed in parallel with, or on the upstream side of, cooling units to avoid condensation in the heating compartment. With a parallel flow arrangement, a damper (or other means to control the flow of air) must adequately prevent chilled air from entering the furnace. If the damper is manually operated, it must be equipped to prevent operation of either the heating or the cooling unit, unless it is in the full **HEAT or COOL** setting. See Figure 2.

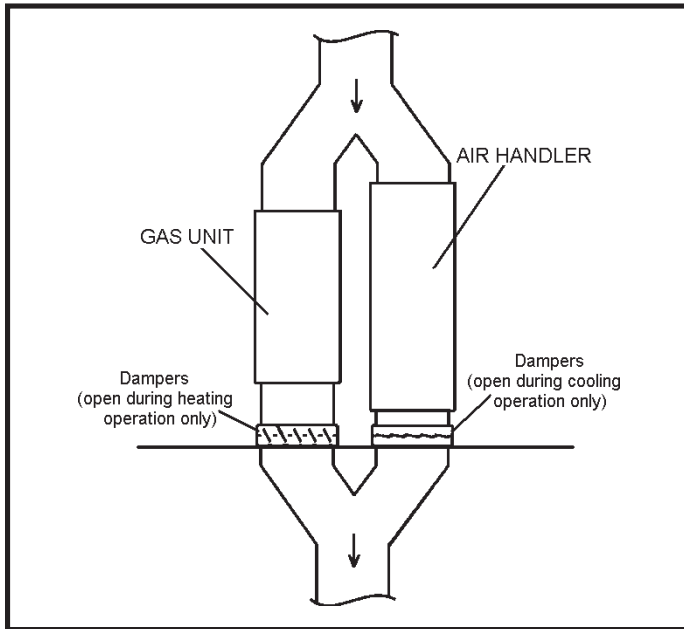

Figure 2

When installed, this furnace must be electrically grounded according to local codes. In addition, in the United States, installation must conform with the current National Electric Code, ANSI/NFPA No. 70. The National Electric Code (ANSI/NFPA No. 70) is available from the following address:

National Fire Protection Association  
1 Battery March Park  
Quincy, MA 02269

**NOTE:** *This furnace is designed for a minimum continuous return air temperature of 60° F (16°C) or an intermittent operation down to 55° F (13°C) dry bulb for cases where a night setback thermostat is used. Return air temperature must not exceed 85° F (29°C) dry bulb.*

This furnace may be installed in alcoves, closets, attics, basements, garages, and utility rooms in the downflow position.

**This furnace design has not been certified for installation in mobile homes, recreational vehicles, or outdoors.**

### Use of Furnace as a Construction Heater

Allied Air does not recommend the use of these units as a construction heater during any phase of construction. Very low return air temperature, harmful vapors and operation of the unit with clogged or misplaced filters will damage the unit.

Units may be used for heating of buildings or structures under construction, if the following conditions are met:

- The vent system must be permanently installed per these installation instructions.
- A room thermostat must control the furnace. The use of fixed jumpers that will provide continuous heating is not allowed.
- The return air duct must be provided and sealed to the furnace.
- Return air temperature range between 60°F (16°C) and 80°F (27°C) must be maintained.
- Air filters must be installed in the system and must be maintained during construction.
- Air filters must be replaced upon construction completion.
- The input rate and temperature rise must be set per the furnace rating plate.
- One hundred percent (100%) outdoor air must be provided for combustion air requirements during construction. Temporary ducting may supply outdoor air to the furnace. Do not connect duct directly to the furnace. Size the temporary duct following these instructions in section for Combustion, Dilution and Ventilation Air in a confined space with air from outside.
- The furnace heat exchanger, components, duct system, air filters and evaporator coils must be thoroughly cleaned following final construction clean-up.
- All furnace operating conditions (including ignition, input rate, temperature rise and venting) must be verified according to these installation instructions.

## General

These instructions are intended as a general guide and do not supersede local codes in any way. Consult authorities having jurisdiction before installation.

In addition to the requirements outlined previously, the following general recommendations must be considered when installing one of these furnaces:

- Place the furnace as close to the center of the air distribution system as possible. The furnace should also be located close to the chimney or vent termination point.
- Do not install the furnace where drafts might blow directly into it. This could cause improper combustion.
- Do not block the furnace combustion air openings with clothing, boxes, doors, etc. Air is needed for proper combustion and safe unit operation.
- When the furnace is installed in an attic or other insulated space, keep insulation away from the furnace.

**NOTE:** *The Commonwealth of Massachusetts stipulates these additional requirements:*

- Gas furnaces shall be installed by a licensed plumber or fitter only.
- The gas cock must be "T handle" type.
- When a furnace is installed in an attic, the passageway to and service area surrounding the equipment shall be floored.

### WARNING

The State of California has determined that this product may contain or produce a chemical or chemicals, in very low doses, which may cause serious illness or death. It may also cause cancer, birth defects or other reproductive harm.

## Combustion, Dilution & Ventilation Air

In the past, there was no problem in bringing in sufficient outdoor air for combustion. Infiltration provided all the air that was needed. In today's homes, tight construction practices make it necessary to bring in air from outside for combustion. Take into account that exhaust fans, appliance vents, chimneys, and fireplaces force additional air that could be used for combustion out of the house. Unless outside air is brought into the house for combustion, negative pressure (outside pressure is greater than inside pressure) will build to the point that a downdraft can occur in the furnace vent pipe or chimney. As a result, combustion gases enter the living space creating a potentially dangerous situation.

In the absence of local codes concerning air for combustion and ventilation, use the guidelines and procedures in this section to install these furnaces to ensure efficient and safe operation. You must consider combustion air needs and requirements for exhaust vents and other gas appliances.

A portion of this information has been reprinted with permission from the National Fuel Gas Code (ANSI-Z223.1). This reprinted material is not the complete and official position of the ANSI on the referenced subject, which is represented only by the standard in its entirety.

### CAUTION

DO NOT install the furnace in a corrosive or contaminated atmosphere. Meet all combustion and ventilation air requirements, as well as all local codes.

### WARNING

Insufficient combustion air can cause headaches, nausea, dizziness or asphyxiation. It will also cause excess water in the heat exchanger resulting in rusting and premature heat exchanger failure. Excessive exposure to contaminated combustion air will result in safety and performance related problems. Avoid exposure to the following substances in the combustion air supply:

- Permanent wave solutions
- Chlorinated waxes and cleaners
- Chlorine base swimming pool chemicals
- Water softening chemicals
- De-icing salts or chemicals
- Carbon tetrachloride
- Halogen type refrigerants
- Cleaning solvents (such as perchloroethylene)
- Printing inks, paint removers, varnishes, etc.
- Hydrochloric acid
- Cements and glues
- Antistatic fabric softeners for clothes dryers
- Masonry acid washing materials

All gas fired appliances require air for the combustion process. If sufficient combustion air is not available, the furnace or other appliances will operate inefficiently and unsafely. Enough air must be provided to meet the needs of all fuel burning appliances and appliances such as exhaust fans which force air out of the house. When fireplaces, exhaust fans, or clothes dryers are used at the same time as the furnace, much more air is necessary to ensure proper combustion and to prevent a downdraft. Insufficient air causes incomplete combustion which can result in carbon monoxide.

In addition to providing combustion air, fresh outdoor air dilutes contaminants in the indoor air. These contaminants may include bleaches, adhesives, detergents, solvents and other contaminants which can corrode furnace components.

The requirements for providing air for combustion and ventilation depend largely on whether the furnace is installed in an unconfined or a confined space.

**Unconfined Space**

An unconfined space is an area such as a basement or large equipment room with a volume greater than 50 cubic feet (1.42 m<sup>3</sup>) per 1,000 Btu (.29 kW) per hour of the combined input rating of all appliances installed in that space. This space also includes adjacent rooms which are not separated by a door. Though an area may appear to be unconfined, it might be necessary to bring in outdoor air for combustion if the structure does not provide enough air by infiltration. If the furnace is located in a building of tight construction with weather stripping and caulking around the windows and doors, follow the procedures in the air from outside section.

**Confined Space**

A confined space is an area with a volume less than 50 cubic feet (1.42 m<sup>3</sup>) per 1,000 Btu (.29 kW) per hour of the combined input rating of all appliances installed in that space. This definition includes furnace closets or small equipment rooms.

When the furnace is installed so that supply ducts carry air circulated by the furnace to areas outside the space containing the furnace, the return air must be handled by ducts which are sealed to the furnace casing and which terminate outside the space containing the furnace. This is especially important when the furnace is mounted on a platform in a confined space such as a closet or small equipment room. Even a small leak around the base of the unit at the platform or at the return air duct connection can cause a potentially dangerous negative pressure condition. Air for combustion and ventilation can be brought into the confined space either from inside the building or from outside.

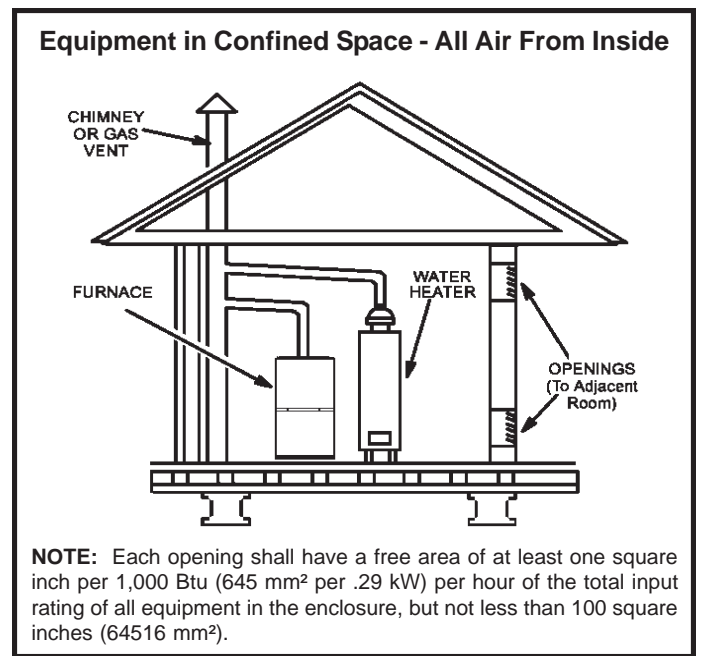

**Figure 3**

**Air from Inside**

If the confined space that houses the furnace adjoins a space categorized as unconfined, air can be brought in by providing two permanent openings between the two spaces. Each opening must have a minimum free area of 1 square inch (645 mm<sup>2</sup>) per 1,000 Btu (.29 kW) per hour of total input rating of all gas fired equipment in the confined space. Each opening must be at least 100 square inches (64516 mm<sup>2</sup>). One opening shall be within 12 inches (305 mm) of the top of the enclosure and one opening within 12 inches (305 mm) of the bottom. See Figure 3.

**Air from Outside**

If air from outside is brought in for combustion and ventilation, the confined space must have two permanent openings. One opening shall be within 12 inches (305 mm) of the top of the enclosure and one opening within 12 inches (305 mm) of the bottom. These openings must communicate directly or by ducts with the outdoors or spaces (crawl or attic) that freely communicate with the outdoors or indirectly through vertical ducts. Each opening shall have a minimum free area of 1 square inch (645 mm<sup>2</sup>) per 4,000 Btu (1.17 kW) per hour of total input rating of all equipment in the enclosure. See Figures 4 and 5. When communicating with the outdoors through horizontal ducts, each opening shall have a minimum free area of 1 square inch (645 mm<sup>2</sup>) per 2,000 Btu (.56 kW) per total input rating of all equipment in the enclosure. See Figure 6.

When ducts are used, they shall be of the same cross sectional area as the free area of the openings to which they connect. The minimum dimension of rectangular air ducts shall be no less than 3 inches (75 mm). In calculating free area, the blocking effect of louvers, grilles, or screens must be considered. If the design and free area of protective covering is not known for calculating the size opening required, it may be assumed that wood louvers will have 20 to 25 percent free area and metal louvers and grilles will have 60 to 75 percent free area. Louvers and grilles must be fixed in the open position or interlocked with the equipment so that they are opened automatically during equipment operation.

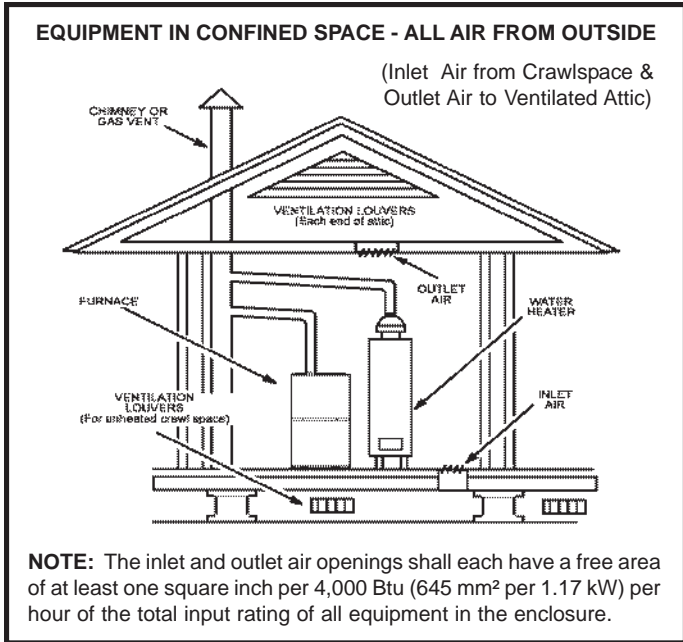

Figure 4

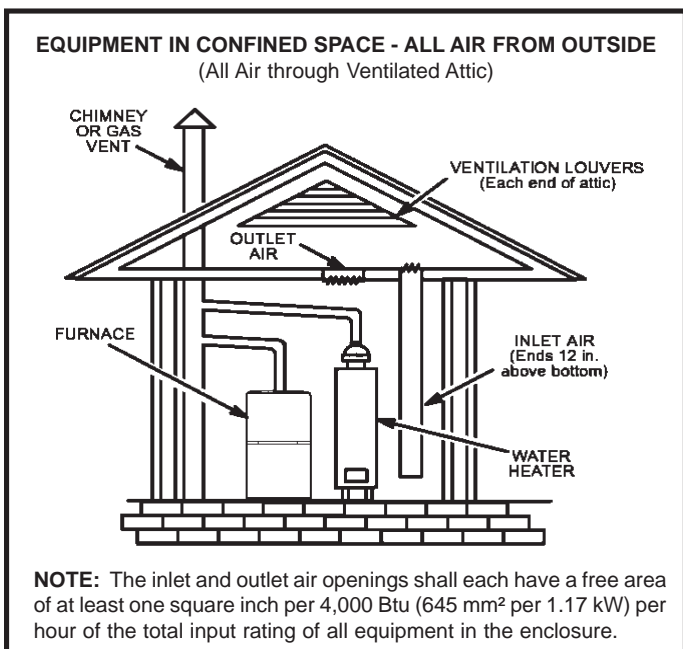

Figure 5

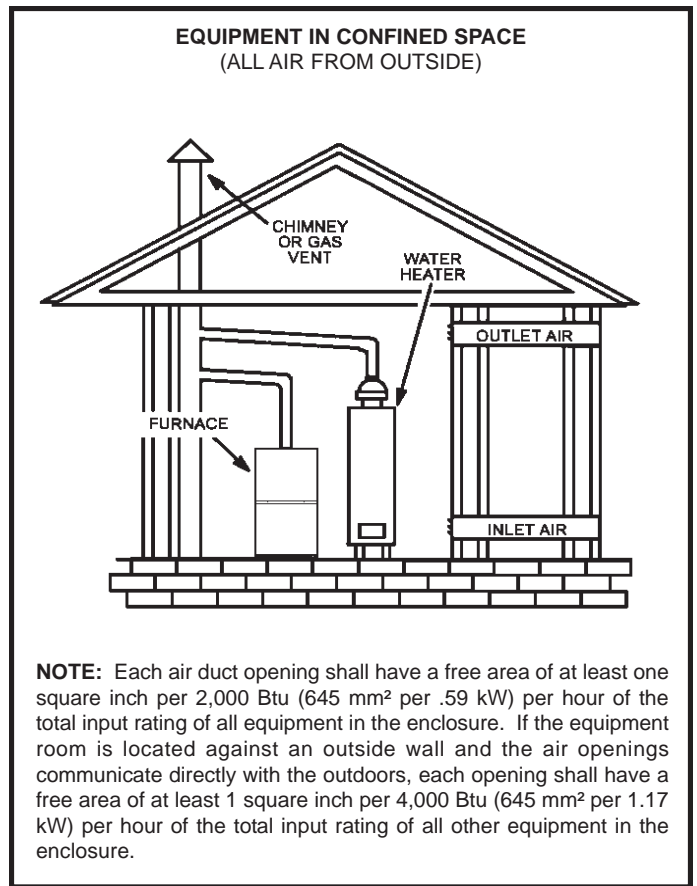

Figure 6



### Downflow Installation

Downflow unit installs in three ways: on non-combustible flooring, on combustible flooring using a downflow combustible flooring base, or on a reverse flow cooling cabinet. Do not drag the unit across the floor.

#### Installation on Non-Combustible Flooring (Figure 7)

1. Cut floor opening keeping in mind clearances listed on unit rating plate. Also keep in mind gas supply connections, electrical supply, flue and air intake connections and sufficient installation and servicing clearances. See Table 1 for correct floor opening size.
2. Flange warm air plenum and lower the plenum into the opening.
3. Set the unit over the plenum and seal the plenum to the unit.
4. Ensure that the seal is adequate.

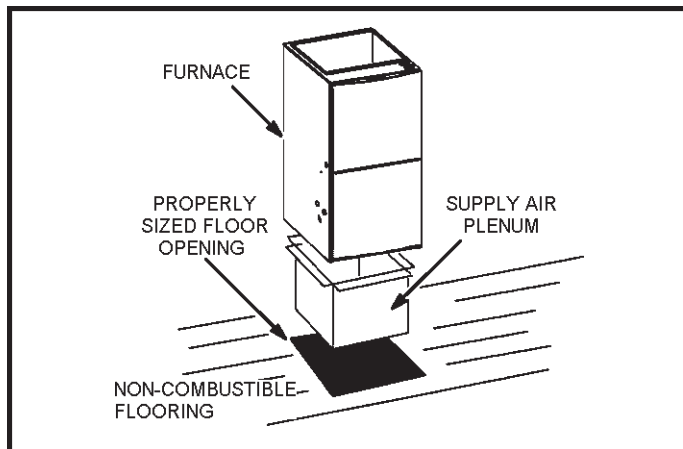

Figure 7

NON-COMBUSTIBLE FLOOR OPENING SIZE				
Cabinet Width	Front to Rear		Side to Side	
	in.	mm	in.	mm
A (14.5")	19-3/4	502	13-1/4	337
B (17.5")	19-3/4	502	16-1/4	413
C (21")	19-3/4	502	19-3/4	502

**NOTE:** Floor opening dimensions listed are 1/4 inch (6 mm) larger than the unit opening. See unit dimensions on page 2.

Table 1

#### Installation on Combustible Flooring (Figure 8)

1. When unit is installed on a combustible floor, a downflow combustible flooring base must be installed between the furnace and the floor. The base must be ordered separately.

See Table 2 for opening size to cut in floor.

2. After opening is cut, set combustible flooring base into opening.

**CAUTION**

The furnace and downflow combustible flooring base shall not be installed directly on carpeting, tile, or other combustible material other than wood flooring.

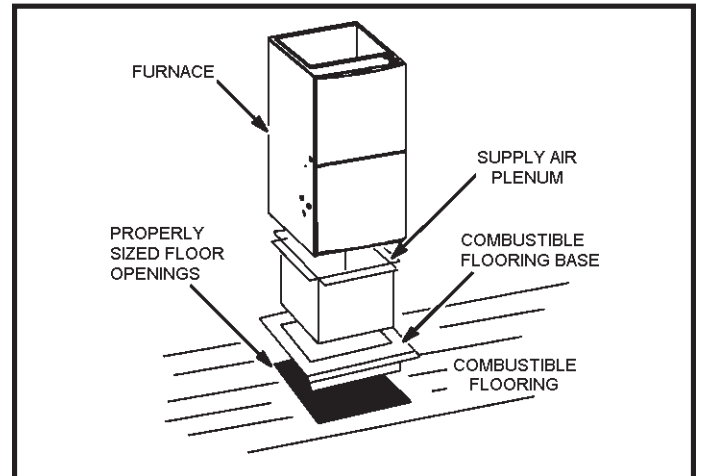

Figure 8

COMBUSTIBLE FLOOR OPENING SIZE				
Cabinet Width	Front to Rear		Side to Side	
	in.	mm	in.	mm
A (14.5")	22	559	15-3/4	400
B (17.5")	22	559	18-3/4	476
C (21")	22	559	22-3/4	578

**NOTE:** Floor opening dimensions listed are 1/4 inch (6 mm) larger than unit opening. See unit dimensions on page 2.

Table 2

3. Check sealing strips on combustible flooring base to make sure they are properly glued and positioned.
4. Lower supply air plenum into downflow combustible flooring base until plenum flanges seal against the strips.

**NOTE:** Be careful not to damage sealing strips. Check for a tight seal.

5. Set the furnace over the plenum.
6. Ensure that the seal between the furnace and plenum is adequate.

#### Installation on Cooling Cabinet (Figure 9)

1. Refer to reverse flow coil installation instructions for correctly sized opening in floor and installation of cabinet.

**NOTE:** Downflow combustible flooring kit is not used.

2. When cooling cabinet is in place, set and secure the furnace according to the instructions that are provided with the cooling coil. Secure the furnace to the cabinet.
3. Seal the cabinet and check for air leaks.

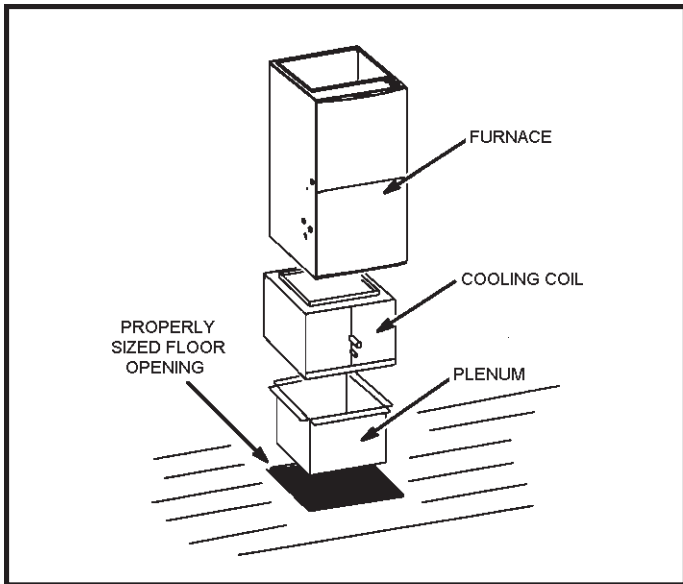

Figure 9

### Return Air Opening — Downflow Units

The following steps should be taken when installing plenum:

1. Bottom edge of plenum should be flanged with a hemmed edge (See Figure 10).

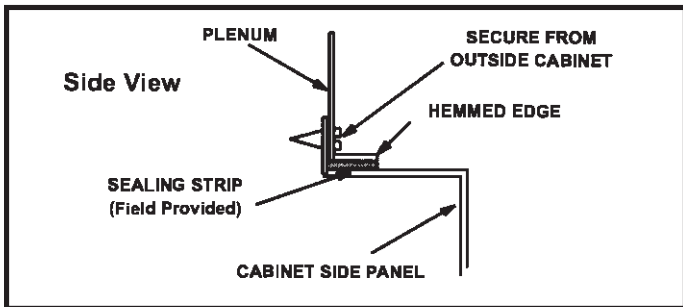

Figure 10

2. Sealing strip should be used.
3. In all cases, plenum should be secured to top flanges of furnace with sheet metal screws.

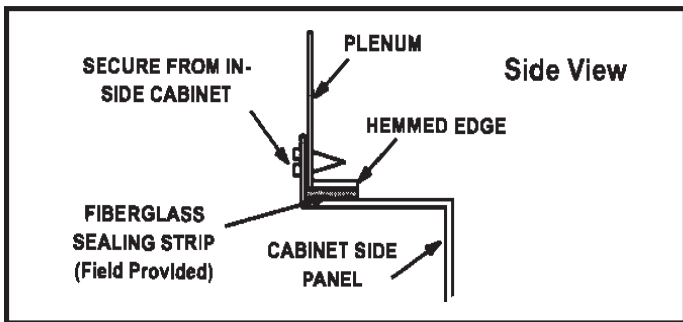

Figure 11

4. In closet installations, it may be impossible to install sheet metal screws from the outside. In this case, make plenum with a removable front and install screws from the inside (See Figure 11).
5. Make certain that an adequate seal is made.

### Setting Equipment



Do not install the furnace on its front, back or in the horizontal position. See Figure 13. Do not connect the return air ducts to the back of the furnace. Doing so will adversely affect the operation of the safety control devices, which could result in personal injury or death.

Install this gas furnace as shipped in the downflow position ONLY. **Do not install the furnace horizontally.**

Select a location that allows for the required clearances that are listed on the unit nameplate. Also consider gas supply connections, electrical supply, vent connection, and installation and service clearances [24 inches (610 mm) at unit front]. *The unit must be level.*

**NOTE:** Units with 1/2 hp blower motors are equipped with three flexible legs and one rigid leg. See Figure 12. The rigid leg is equipped with a shipping bolt and a flat white plastic washer (rather than the rubber mounting grommet used with a flexible mounting leg). **The bolt and washer must be removed before the furnace is placed into operation.** After the bolt and washer have been removed, the rigid leg will not touch the blower housing.

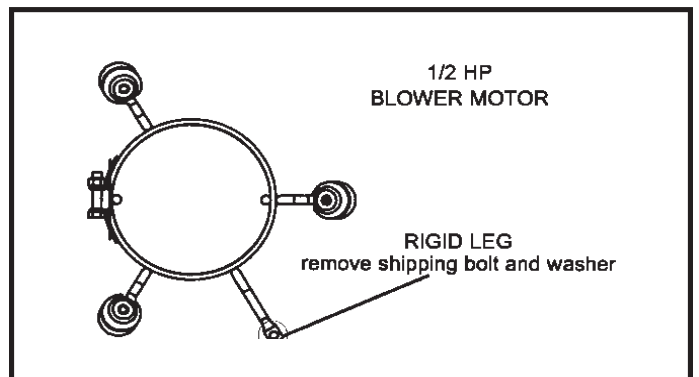

Figure 12



The blower access panel must be securely in place when the blower and burners are operating. Gas fumes, which could contain carbon monoxide, can be drawn into living space resulting in personal injury or death.

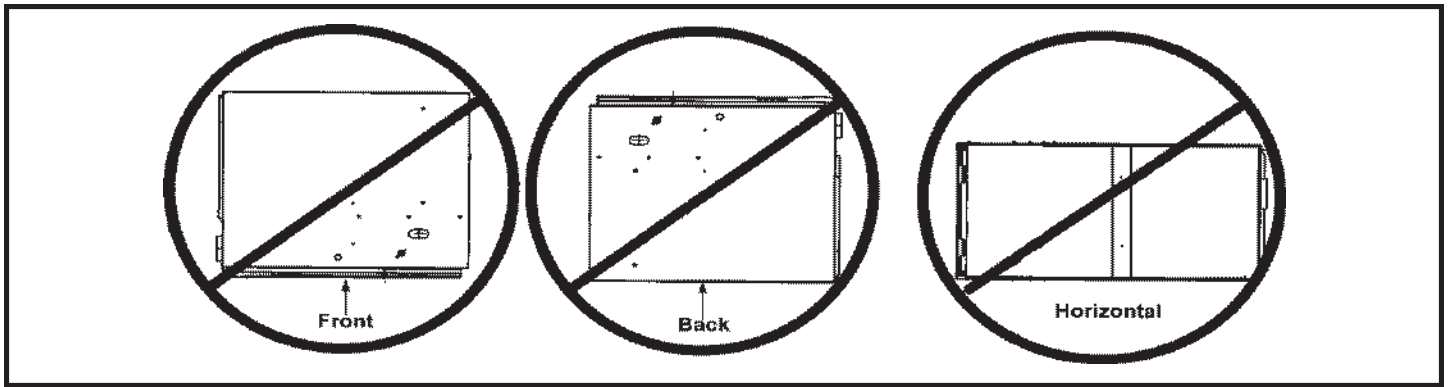

Figure 13

### Downflow Application

Allow for clearances to combustible materials as indicated on the unit nameplate. Minimum clearances for closet or alcove installations are shown in Figure 14

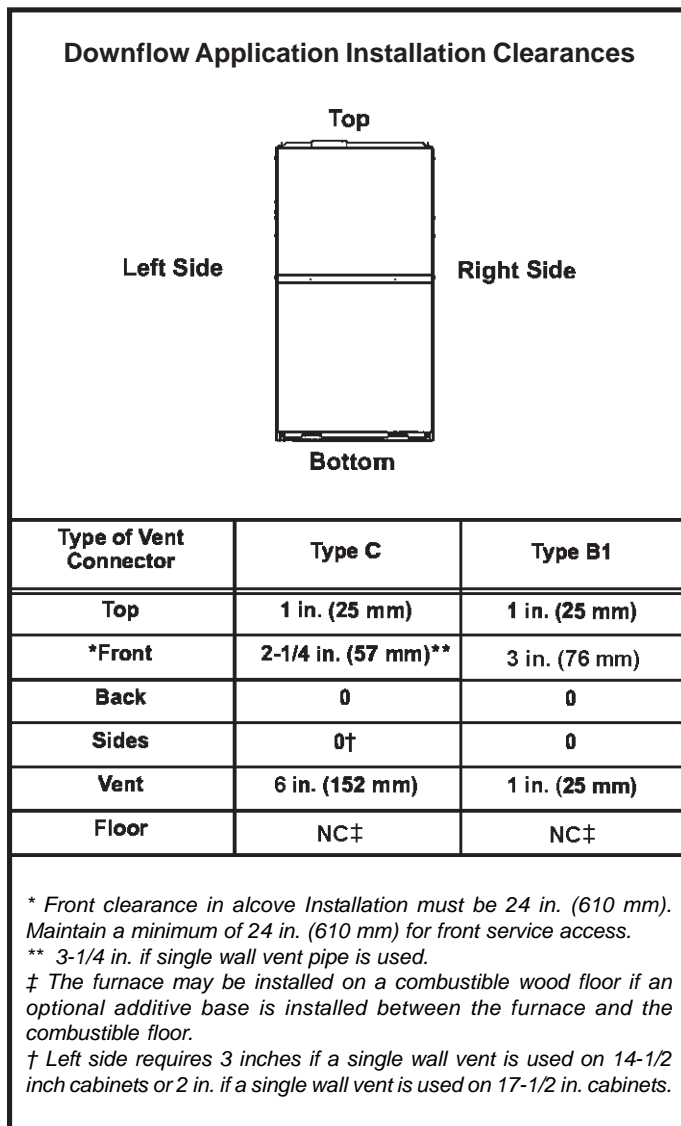

Figure 14

### WARNING

Improper installation of the furnace can result in personal injury or death. Combustion and flue products must never be allowed to enter the return air system or the living space. Use screws and joint tape to seal the return air system to the furnace.

The return and supply air duct systems must never be connected to or from other heating devices such as a fireplace or stove, etc. Fire, explosion, carbon monoxide poisoning, personal injury and/or property damage could result.

### Filters

This unit is not equipped with a filter or rack. A field provided high velocity filter is required for the unit to operate properly. Table 3 lists recommended filter sizes.

A filter must be in place any time the unit is operating.

Cabinet Width	Return Air Filter Size (inches)
A (14-1/2")	14 x 25 x 1
B (17-1/2")	16 x 25 x 1
C (21")	20 x 25 x 1

Table 3

### Duct System

Use industry approved standards (such as those published by Air Conditioning Contractors of America or American Society of Heating, Refrigerating and Air Conditioning Engineers) to size and install the supply and return air duct system. This will result in a quiet and low static system that has uniform air distribution.

**NOTE:** Do not operate the furnace in the heating mode with an external static pressure that exceeds 0.8 inches w.c. Higher external static pressures may cause erratic limit operation.

Ensure that you have made a seal between the supply air plenum and the furnace and between the furnace and the return air plenum.

### Supply Air Plenum

If the furnace is installed without a cooling coil, a removable access panel should be installed in the supply air duct. The access panel should be large enough to permit inspection (either by smoke or reflected light) of the heat exchanger for leaks after the furnace is installed.

### Return Air Plenum

Return air must not be drawn from a room where this furnace, or any other gas fueled appliance (i.e., water heater), or carbon monoxide producing device (i.e., wood fireplace) is installed. When return air is drawn from a room, a negative pressure is created in the room. If a gas appliance is operating in a room with negative pressure, the flue products can be pulled back down the vent pipe and into the room. This reverse flow of the flue gas may result in incomplete combustion and the formation of carbon monoxide gas. This toxic gas might then be distributed throughout the house by the furnace duct system.

### Venting

A 4 inch diameter flue transition is factory installed on all models. Modifying or removing the flue transition will cause the unit to operate unsafely and will void the unit certification. The vent connector does not require insulation.

This series of units are classified as fan assisted Category I furnaces when vertically vented according to the latest edition of National Fuel Gas Code (NFPA 54 1 ANSI Z223.1). A fan assisted Category I furnace is an appliance equipped with an integral mechanical means to either draw or force combustion products through the combustion chamber *and/* or heat exchanger. **This unit is not approved for use with horizontal venting.**

**NOTE:** Use these instructions as a guide. They do not supersede local codes. This furnace must be vented according to all local codes, these installation instructions, and the provided venting tables in these instructions.

The venting tables in this manual were extracted from the National Fuel Gas Code (NFPA 541 ANSI Z223.1) and are provided as a guide for proper vent installation. Proper application, termination, construction and location of vents must conform to local codes having jurisdiction. In the absence of local codes, the NFGC serves as the defining document.

Refer to the tables and the venting information contained in these instructions to properly size and install the venting system.

### IMPORTANT

Once the venting system is installed, attach the "Disconnected Vent" warning sticker to a visible area of the plenum near the vent pipe. The warning sticker is provided in the bag assembly.

### WARNING

Asphyxiation hazard. The exhaust vent for this furnace must be securely connected to the furnace flue transition at all times.

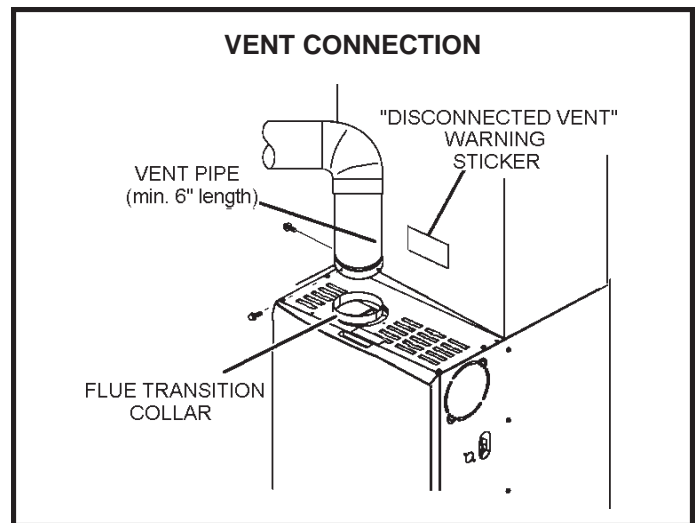

Figure 15

Use self drilling sheet metal screws or a mechanical fastener to firmly secure the vent pipe to the round collar of the flue transition. If self drilling screws are used to attach the vent pipe, it is recommended that three be used. Drive one self drilling screw through the front and one through each side of the vent pipe and collar. See Figure 15.

Install the first vent connector elbow at a minimum of six inches (152 mm) from the furnace vent outlet.

## Common Venting Using Tile lined Interior Masonry Chimney and Combined Vent Connector

**NOTE:** Refer to provided venting tables for installations.

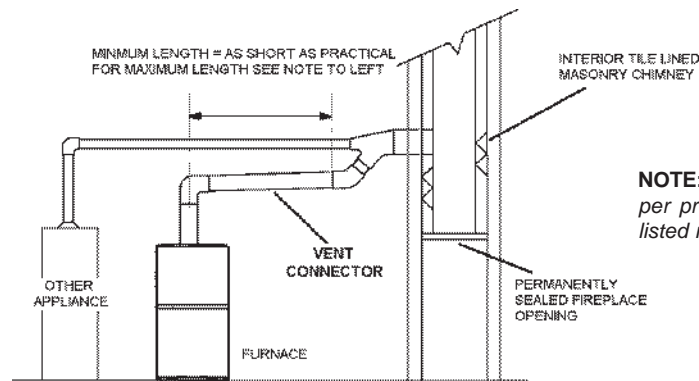

**NOTE:** The chimney must be properly sized per provided venting tables or lined with listed metal lining system.

Figure 16

### Venting Using a Masonry Chimney

The following additional requirements apply when a lined masonry chimney is used to vent this furnace.

Masonry chimneys used to vent Category I central furnaces must be either tile lined or lined with a listed metal lining system or dedicated gas vent. Unlined masonry chimneys are prohibited. See Figures 16 and 17 for common venting.

A chimney with one or more sides exposed to the outside of the structure is considered to be an exterior chimney.

An exterior masonry chimney that is not tile lined must be lined with B 1 vent or a listed insulated flexible metal vent. An exterior tile lined chimney that is sealed and capped may be lined with a listed uninsulated flexible metal vent.

If the existing chimney will not accommodate a listed metal liner, either the chimney must be rebuilt to accommodate one of these liners or an alternate approved venting method must be found.

Insulation for the flexible vent pipe must be an encapsulated fiberglass sleeve recommended by the flexible vent pipe manufacturer.

**DO NOT insulate the space between the liner and the chimney wall with puffed mica or any other loose granular insulating material.**

### **IMPORTANT**

**SINGLE** appliance venting of a fan assisted furnace into a tile lined masonry chimney (interior or outside wall) is **PROHIBITED**. The chimney must first be lined with either type B1 vent or an insulated single wall flexible vent lining system which has been sized according to the provided venting tables and the vent pipe manufacturer's instructions.

A fan assisted furnace may be commonly vented into an existing lined masonry chimney if the following conditions are met:

- The chimney is currently serving at least one drafthood equipped appliance.
- The vent connectors and chimney are sized according to the provided venting tables.

### Common Venting Using Metal Lined Masonry Chimney

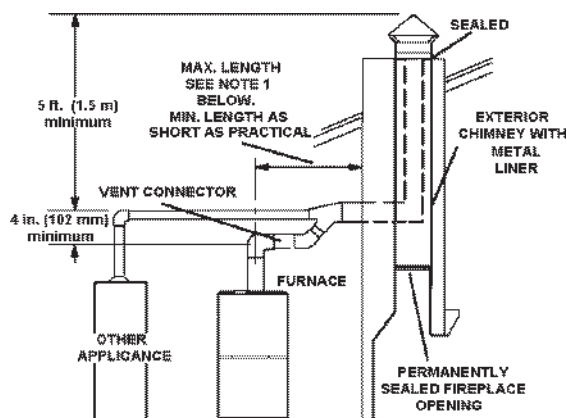

NOTE 1: Refer to the provided venting tables for installations.

Figure 17

If type B1 double wall vent is used inside a chimney, no other appliance can be vented into the chimney. The outer wall of type B1 vent pipe must not be exposed to flue products. A type B1 vent or masonry chimney liner shall terminate above the roof surface with a listed cap or a listed roof assembly according to the terms of their respective listings and the vent manufacturer's instructions.

When inspection reveals that an existing chimney is not safe for the intended purpose, it shall be rebuilt to conform to nationally recognized standards, lined or relined with suitable materials, or replaced with a gas vent or chimney suitable for venting units. The chimney passageway must be checked periodically to ensure that it is clear and free of obstructions.

Do not install a manual damper, barometric draft regulator, or flue restrictor between the furnace and the chimney.

Never connect a Category I appliance to a chimney that is servicing a solid fuel appliance. If a fireplace chimney flue is used to vent this appliance, the fireplace opening must be permanently sealed.

A type B 1 or listed chimney lining system that passes through an unused masonry chimney flue is not considered to be exposed to the outdoors.

### General Venting Requirements

Vent all furnaces according to these instructions:

1. Vent diameter recommendations and maximum allowable piping runs are found in the provided venting tables.
2. In no case should the vent or vent connector diameter be less than the diameter specified in the provided venting tables.
3. The minimum vent capacity determined by the sizing tables must be less than the low fire input rating and the maximum vent capacity must be greater than the high fire input rating.
4. *Single appliance vents* - If the vertical vent or tile-lined chimney has a larger diameter or flow area than the vent connector, use the **vertical vent diameter** to determine the **minimum vent capacity** and the vent **connector diameter** to determine the **maximum vent capacity**. The flow area of the vertical vent, however, shall not exceed 7 times the flow area of the listed appliance categorized vent area, draft hood outlet area or flue collar area unless designed according to approved engineering methods.
5. *Multiple appliance vents* - The flow area of the largest section of vertical vent or chimney shall not exceed 7 times the smallest listed appliance categorized vent area, draft hood outlet area or flue collar area unless designed according to approved engineering methods.
6. The entire length of single wall metal vent connector shall be readily accessible for inspection, cleaning, and replacement.
7. Single appliance venting configurations with zero lateral lengths (Tables 5 and 6) are assumed to have no elbows in the vent system. For all other vent configurations, the vent system is assumed to have two 90° elbows. For each additional 90° elbow or equivalent (for example two 45° elbows equal one 90° elbow) beyond two, the maximum capacity listed in the venting table should be reduced by 10% (0.90 x maximum listed capacity).
8. The common venting Tables (7, 8, 9, and 10) were generated using a maximum horizontal vent connector length of 1-1/2 feet (.46 m) for each inch (25 mm) of connector diameter as follows:

Connector Diameter inches (mm)	Maximum Horizontal Connector Length feet (m)
3 (76)	4-1/2 (1.37)
4 (102)	6 (1.83)
5 (127)	7-1/2 (2.29)
6 (152)	9 (2.74)
7 (178)	10-1/2 (3.20)

Table 4

9. If the common vertical vent is offset, the maximum common vent capacity listed in the common venting tables should be reduced by 20%, the equivalent of two 90° elbows (0.80 x maximum common vent capacity). The horizontal length of the offset shall not exceed 1-1/2 feet (.46 m) for each inch (25 mm) of common vent diameter.
10. The vent pipe should be as short as possible with the least number of elbows and angles required to complete the job. Route the vent connector to the vent using the shortest possible route.
11. A vent connector shall be supported without any dips or sags and shall slope a minimum of 1/4 inch (6.4 mm) per linear foot (305 mm) of connector, back toward the appliance.
12. Vent connectors shall be firmly attached to the furnace flue collar by self drilling screws or other approved means, except vent connectors of listed type B vent material which shall be assembled according to the manufacturer's instructions. Joints between sections of single wall connector piping shall be fastened by screws or other approved means.
13. When the vent connector used for Category I appliances must be located in or pass through a crawl space or other areas which may be cold, that portion of the vent connector shall be constructed of listed double wall type B vent material or material having equivalent insulation qualities.
14. All venting pipe passing through floors, walls, and ceilings must be installed with the listed clearance to combustible materials and be fire stopped according to local codes. In absence of local codes, refer to NFGC (Z223.1).
15. No portion of the venting system can extend into, or pass through any circulation air duct or plenum.
16. Vent connectors serving Category I appliances shall not be connected to any portion of mechanical draft systems operating under positive pressure such as Category III or IV venting systems.
17. If vent connectors are combined prior to entering the common vent, the maximum common vent capacity listed in the common venting tables must be reduced by 10%, the equivalent of one 90° elbow (0.90 x maximum common vent capacity).

18. The common vent diameter must always be at least as large as the largest vent connector diameter.
19. In no case, shall the vent connector be sized more than two consecutive table size diameters over the size of the draft hood outlet or flue collar outlet.
20. Do not install a manual damper, barometric draft regulator or flue restrictor between the furnace and the chimney.
21. When connecting this appliance to an existing dedicated or common venting system, you must inspect the venting system's general condition and look for signs of corrosion. The existing vent pipe size must conform to these instructions and the provided venting tables. If the existing venting system does not meet these requirements, it must be resized.

**Capacity of Type B Double Wall Vents with Type B Double Wall Connectors  
Serving a Single Category I Appliance**

Hsight H (fset)	Lateral L (feet)	Vsent and Connector Diameter - D (Inches)							
		3 Inch		4 Inch		5 Inch		6 Inch	
		Appliance Input Rating in Thousands of Btu Per Hour							
		MIN	MAX	MIN	MAX	MIN	MAX	MIN	MAX
6	0	0	78	0	152	0	251	0	375
	2	13	51	18	97	27	157	32	232
	4	21	49	30	94	39	153	50	227
	6	25	46	36	91	47	149	59	223
8	0	0	84	0	165	0	276	0	415
	2	12	57	16	109	25	178	28	263
	5	23	53	32	103	42	171	53	255
	8	28	49	39	98	51	164	64	247
10	0	0	88	0	175	0	295	0	447
	2	12	61	17	118	23	194	26	289
	5	23	57	32	113	41	187	52	280
	10	30	51	41	104	54	176	67	267
15	0	0	94	0	191	0	327	0	502
	2	11	69	15	136	20	226	22	339
	5	22	65	30	130	39	219	49	330
	10	29	59	40	121	51	206	64	315
	15	35	53	48	112	61	195	76	301
20	0	0	97	0	202	0	349	0	540
	2	10	75	14	149	18	250	20	377
	5	21	71	29	143	38	242	47	367
	10	28	64	38	133	50	229	62	351
	15	34	58	46	124	59	217	73	337
	20	48	52	55	116	69	206	84	322
30	0	0	100	0	213	0	374	0	587
	2	9	81	13	166	14	283	18	432
	5	21	77	28	160	36	275	45	421
	10	27	70	37	150	48	262	59	405
	15	33	64	44	141	57	249	70	389
	20	56	58	53	132	66	237	80	374
	30	NR	NR	73	113	88	214	104	346

**NOTE:** Single appliance venting configurations with zero lateral lengths are assumed to have no elbows in the vent system. For all other vent configurations, the vent system is assumed to have two 90° elbows. For each additional 90° elbow or equivalent (for example two 45° elbows equal one 90° elbow) beyond two, the maximum capacity listed in the venting table should be reduced by 10 percent (0.90 x maximum listed capacity).

**Table 5**

**Capacity of Type B Double Wall Vents with Single-Wall Metal Connectors  
Serving a Single Category I Appliance**

Height H (feet)	Lateral L (feet)	Vent and Connector Diameter - D (Inchee)							
		3 inch		4 inch		5 inch		6 inch	
		Appliance Input Rating in Thoueande of Btu Per Hour							
		MIN	MAX	MIN	MAX	MIN	MAX	MIN	MAX
6	0	38	77	59	151	85	249	126	373
	2	39	51	60	96	85	156	123	231
	4	NR	NR	74	92	102	152	146	225
	6	NR	NR	83	89	114	147	163	220
8	0	37	83	58	164	83	273	123	412
	2	39	56	59	108	83	176	121	261
	5	NR	NR	77	102	107	168	151	252
	8	NR	NR	90	95	122	161	175	243
10	0	37	87	57	174	82	293	120	444
	2	39	61	59	117	82	193	119	287
	5	52	56	76	111	105	185	148	277
	10	NR	NR	97	100	132	171	188	261
15	0	36	93	56	190	80	325	116	499
	2	38	69	57	136	80	225	115	337
	5	51	63	75	128	102	216	144	326
	10	NR	NR	95	116	128	201	182	308
	15	NR	NR	NR	NR	158	186	220	290
20	0	35	96	54	200	78	346	114	537
	2	37	74	56	148	78	248	113	375
	5	50	68	73	140	100	239	141	363
	10	NR	NR	93	129	125	223	177	344
	15	NR	NR	NR	NR	155	208	216	325
	20	NR	NR	NR	NR	186	192	254	306
30	0	34	99	53	211	76	372	110	584
	2	37	80	55	164	76	281	109	429
	5	49	74	72	157	98	271	136	417
	10	NR	NR	91	144	122	255	171	397
	15	NR	NR	115	131	151	239	208	377
	20	NR	NR	NR	NR	181	223	246	357
	30	NR	NR	NR	NR	NR	NR	NR	NR

**NOTE:** Single appliance venting configurations with zero lateral lengths are assumed to have no elbows in the vent system. For all other vent configurations, the vent system is assumed to have two 90° elbows. For each additional 90° elbow or equivalent (for example two 45° elbows equal one 90° elbow) beyond two, the maximum capacity listed in the venting table should be reduced by 10 percent (0.90 x maximum listed capacity).

**Table 6**



**Vent Connector Capacity**  
**Type B Double Wall Vents with Type B Double Wall Connectors**  
**Serving Two or More Category I Appliances**

Vent Height H (feet)	Connector Rise R (feet)	Vent and Connector Diameter - D (inches)							
		3 Inch		4 Inch		5 Inch		6 inch	
		Appliance Input Rating in Thousands of Btu Per Hour							
		MIN	MAX	MIN	MAX	MIN	MAX	MIN	MAX
6	1	22	37	35	66	46	106	58	164
	2	23	41	37	75	48	121	60	183
	3	24	44	38	81	49	132	62	199
8	1	22	40	35	72	49	114	64	176
	2	23	44	36	80	51	128	66	195
	3	24	47	37	87	53	139	67	210
10	1	22	43	34	78	49	123	85	189
	2	23	47	36	86	51	136	67	206
	3	24	50	37	92	52	146	69	220
15	1	21	50	33	89	47	142	64	220
	2	22	53	35	96	49	153	66	235
	3	24	55	36	102	51	163	68	248
20	1	21	54	33	99	46	157	62	246
	2	22	57	34	105	48	167	64	259
	3	23	60	35	110	50	176	66	271
30	1	20	62	31	113	45	181	60	288
	2	21	64	33	118	47	190	62	299
	3	22	66	34	123	48	198	64	309

Table 7

**Common Vent Capacity**  
**Type B Double Wall Vents with Type B Double Wall Connectors**  
**Serving Two or More Category I Appliances**

Vent Height H (feet)	Common Vent Diameter - D (Inchee)							
	4 Inch		5 Inch		6 Inch		7 Inch	
	Appliance Input Rating in Thoueande of Btu Per Hour							
	FAN + FAN	FAN + NAT	FAN + FAN	FAN + NAT	FAN + FAN	FAN + NAT	FAN + FAN	FAN + NAT
6	92	81	140	116	204	161	309	248
8	101	90	155	129	224	178	339	275
10	110	97	169	141	243	194	367	299
15	125	112	195	164	283	228	427	352
20	136	123	215	183	314	255	475	394
30	152	138	244	210	361	297	547	459

Table 8

**Vent Connector Capacity**  
**Type B Double Wall Vents with Single Wall Metal Connectors**  
**Serving Two or More Category I Appliances**

Height H (feet)	Lateral L (feet)	Vent and Connector Diameter - D (inches)							
		3 inch		4 inch		5 inch		6 inch	
		Appliance Input Rating in Thousands of Btu Per Hour							
		MIN	MAX	MIN	MAX	MIN	MAX	MIN	MAX
6	1	NR	NR	NR	NR	NR	NR	NR	NR
	2	NR	NR	NR	NR	NR	NR	168	182
	3	NR	NR	NR	NR	121	131	175	198
8	1	NR	NR	NR	NR	NR	NA	NR	NR
	2	NR	NR	NR	NR	125	126	184	193
	3	NR	NR	NR	NR	130	138	191	208
10	1	NR	NR	NR	NR	119	121	182	186
	2	NR	NR	84	85	124	134	189	203
	3	NR	NR	89	91	129	144	197	217
15	1	NR	NR	79	87	116	138	177	214
	2	NR	NR	83	94	121	150	185	230
	3	NR	NR	87	100	127	160	193	243
20	1	49	56	78	97	115	152	175	238
	2	52	59	82	103	120	163	182	252
	3	55	62	87	107	125	172	190	264
30	1	47	60	77	110	112	175	169	278
	2	51	62	81	115	117	185	177	290
	3	54	64	85	119	122	193	185	300

**NOTE:** Single appliance venting configurations with zero lateral lengths are assumed to have no elbows in the vent system. For all other vent configurations, the vent system is assumed to have two 90° elbows. For each additional 90° elbow or equivalent (for example two 45° elbows equal one 90° elbow) beyond two, the maximum capacity listed in the venting table should be reduced by 10 percent (0.90 x maximum listed capacity).

Table 9

**Common Vent Capacity**  
**Type B Double Wall Vents with Single Wall Metal Connectors**  
**Serving Two or more Category I Appliances**

Vent Height H (feet)	Common Vent Diameter - D (inches)							
	4 inch		5 inch		6 inch		7 inch	
	Appliance Input Rating in Thousands of Btu Per Hour							
	FAN + FAN	FAN + NAT	FAN + FAN	FAN + NAT	FAN + FAN	FAN + NAT	FAN + FAN	FAN + NAT
6	NA	78	NA	113	200	158	304	244
8	NA	87	NA	126	218	173	331	269
10	NA	94	163	137	237	189	357	292
15	121	108	189	159	275	221	416	343
20	131	118	208	177	305	247	463	383
30	145	132	236	202	350	286	533	446

Table 10

### Removal of the Furnace from Common Vent

In the event that an existing furnace is removed from a venting system commonly run with separate gas appliances, the venting system is likely to be too large to properly vent the remaining attached appliances.

Conduct the following test while each appliance is operating and the other appliances (which are not operating) remain connected to the common venting system. If the venting system has been installed improperly, you must correct the system as indicated in the general venting requirements section.

#### **WARNING**

#### **CARBON MONOXIDE POISONING HAZARD**

Failure to follow the steps outlined below for each appliance connected to the venting system being placed into operation could result in carbon monoxide poisoning or death.

The following steps shall be followed for each appliance connected to the venting system being placed into operation, while all other appliances connected to the venting system are not in operation:

1. Seal any unused openings in the common venting system.
2. Inspect the venting system for proper size and horizontal pitch. Determine that there is no blockage, restriction, leakage, corrosion, or other deficiencies which could cause an unsafe condition.
3. Close all building doors and windows and all doors between the space in which the appliances remaining connected to the common venting system are located and other spaces of the building. Turn on clothes dryers and any appliances not connected to the common venting system. Turn on any exhaust fans, such as range hoods and bathroom exhausts, so they will operate at maximum speed. Do not operate a summer exhaust fan. Close fireplace dampers.
4. Follow the lighting instructions. Turn on the appliance that is being inspected. Adjust the thermostat so that the appliance operates continuously.
5. After the main burner has operated for 5 minutes, test for leaks of flue gases at the draft hood relief opening. Use the flame of a match or candle, or smoke from a cigarette, cigar, or pipe.
6. After determining that each appliance connected to the common venting system is venting properly, (step 3) return all doors, windows, exhaust fans, fireplace dampers, and any other gas burning appliances to their previous mode of operation.

7. If a venting problem is found during any of the preceding tests, the common venting system must be modified to correct the problem.

Resize the common venting system to the minimum vent pipe size determined by using the appropriate tables in Appendix G. (These are in the current standards of the National Fuel Gas Code ANSI Z223.1.)

### GAS PIPING

#### **CAUTION**

If a flexible gas connector is required or allowed by the authority that has jurisdiction, black iron pipe shall be installed at the gas valve and extend outside the furnace cabinet. The flexible connector can then be added between the black iron pipe and the gas supply line.

#### Gas Supply

1. This unit is shipped standard for left or right side installation of gas piping. Connect the gas supply to the piping assembly.
2. When connecting the gas supply piping, consider factors such as length of run, number of fittings, and furnace rating to avoid excessive pressure drop. Table 11 lists recommended pipe sizes for typical applications.
3. The gas piping must not run in or through air ducts, clothes chutes, gas vents or chimneys, dumbwaiters, or elevator shafts.
4. The piping should be sloped 1/4 inch (6.4 mm) per 15 feet (4.57 m) upward toward the meter from the furnace. The piping must be supported at proper intervals [every 8 to 10 feet (2.44 to 3.01 m)] with suitable hangers or straps. Install a drip leg inside vertical pipe runs to the unit.
5. A 1/8" N.P.T. plugged tap or pressure post is located on the gas valve to facilitate test gauge connection. See Figures 27 and 28.
6. In some localities, codes may require the installation of a manual main shut off valve and union (furnished by the installer) external to the unit. The union must be of the ground joint type.

#### **IMPORTANT**

Compounds used on threaded joints of gas piping must be resistant to the actions of liquified petroleum gases.

**Gas Pipe Capacity - ft<sup>3</sup>/hr (m<sup>3</sup>/hr)**

Nominal Iron Pipe Size inches (mm)	Internal Diameter inches (mm)	Length of Pipe - feet (m)									
		10 (3.048)	20 (6.096)	30 (9.144)	40 (12.192)	50 (15.240)	60 (18.288)	70 (21.336)	80 (24.384)	90 (27.432)	100 (30.480)
1/2 (12.7)	.622 (17.799)	175 (4.96)	120 (3.40)	97 (2.75)	82 (2.32)	73 (2.07)	66 (1.87)	61 (1.73)	57 (1.61)	53 (1.50)	50 (1.42)
3/4 (19.05)	.824 (20.930)	360 (10.19)	250 (7.08)	200 (5.66)	170 (4.81)	151 (4.28)	138 (3.91)	125 (3.54)	118 (3.34)	110 (3.11)	103 (2.92)
1 (25.4)	1.049 (26.645)	680 (919.25)	465 (13.17)	375 (10.62)	320 (9.06)	285 (8.07)	260 (7.36)	240 (6.80)	220 (6.23)	205 (5.80)	195 (5.52)
1-1/4 (31.75)	1.380 (35.052)	1400 (39.64)	950 (26.90)	770 (21.80)	660 (18.69)	580 (16.42)	530 (15.01)	490 (13.87)	460 (13.03)	430 (12.18)	400 (11.33)
1-1/2 (38.1)	1.610 (40.894)	2100 (59.46)	1460 (41.34)	1180 (33.41)	990 (28.03)	900 (25.48)	810 (22.94)	750 (21.24)	690 (19.54)	650 (18.41)	620 (17.56)
2 (50.8)	2.067 (52.502)	3950 (111.85)	2750 (77.87)	2200 (62.30)	1900 (53.80)	1680 (47.57)	1520 (43.04)	1400 (39.64)	1300 (36.81)	1220 (34.55)	1150 (32.56)
2-1/2 (63.5)	2.469 (67.713)	6300 (178.39)	4350 (123.17)	3520 (99.67)	3000 (84.95)	2650 (75.04)	2400 (67.96)	2250 (63.71)	2050 (58.05)	1950 (55.22)	1850 (52.38)
3 (76.2)	3.068 (77.927)	11000 (311.48)	7700 (218.03)	6250 (176.98)	5300 (150.07)	4750 (134.50)	4300 (121.76)	3900 (110.43)	3700 (104.77)	3450 (97.69)	3250 (92.03)

Note: Capacity given in cubic feet (m<sup>3</sup>) of gas per hour and based on 0.60 specific gravity gas.

Table 11

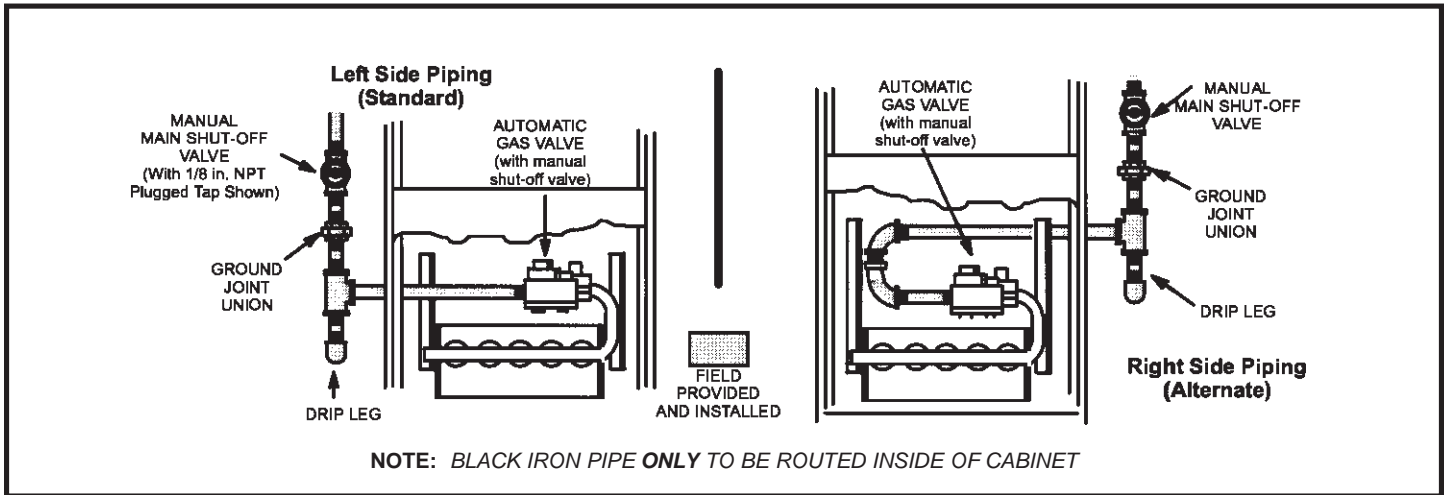

Figure 18

## Leak Check

After gas piping is completed, carefully check all piping connections (factory and field installed) for gas leaks. Use a leak detecting solution or other preferred means.

**NOTE:** If emergency shutoff is necessary, shut off the main manual gas valve and disconnect the main power to the furnace. The installer should properly label these devices.

### CAUTION

Some soaps used for leak detection are corrosive to certain metals. Carefully rinse piping thoroughly after leak test has been completed. Do not use matches, candles, flame or other sources of ignition to check for gas leaks.

The furnace must be isolated by closing its individual manual shut-off valve during any pressure testing of the gas supply system at pressures less than or equal to 1/2 psig (3.48 kPa, 14 inches w.c.).

### IMPORTANT

When testing pressure of gas lines, gas valve must be disconnected and isolated. See Figure 19. Gas valves can be damaged if subjected to pressures greater than 1/2 psig (3.48 kPa, 14 inches w.c.).

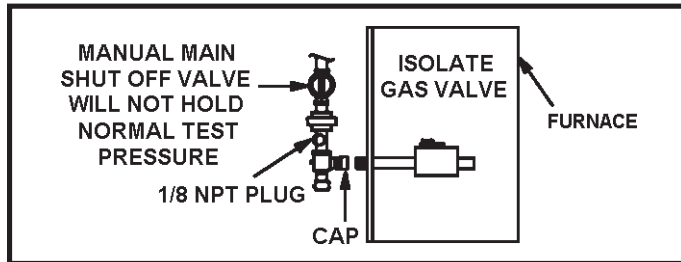

Figure 19

## Electrical

### ELECTROSTATIC DISCHARGE (ESD)

#### Precautions and Procedures

### CAUTION

Electrostatic discharge can affect electronic components. Take precautions during furnace installation and service to protect the furnace's electronic controls. Precautions will help to avoid control exposure to electrostatic discharge by putting the furnace, the control and the technician at the same electrostatic potential. Neutralize electrostatic charge by touching hand and all tools on an unpainted unit surface, such as the gas valve or blower deck, before performing any service procedure.

The unit is equipped with a field make-up box on the left hand side of the cabinet. The make-up box may be moved to the right side of the furnace to facilitate installation. If the make-up box is moved to the right side, clip the wire ties that bundle the wires together. The excess wire must be pulled into the blower compartment. Secure the excess wire to the existing harness to protect it from damage.

### INTERIOR MAKE-UP BOX INSTALLATION

(Left Side)

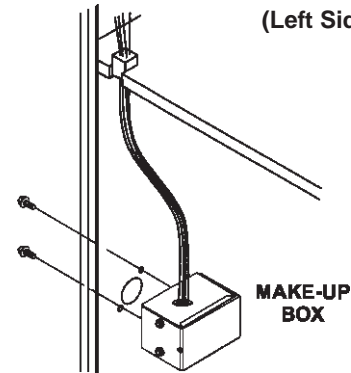

Figure 20

### INTERIOR MAKE-UP BOX INSTALLATION

(Right Side)

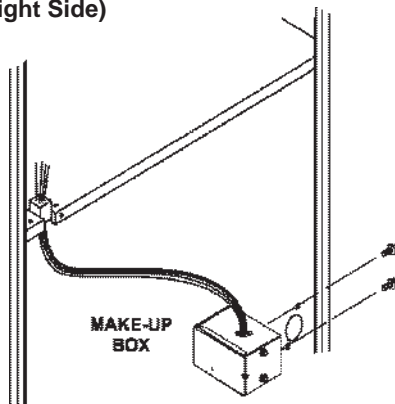

Figure 21

Refer to Figure 24 for schematic wiring diagram and troubleshooting and Figure 25 for field wiring.

1. The power supply wiring must meet Class I restrictions. Protected by either a fuse or circuit breaker, select circuit protection and wire size according to unit nameplate.

**NOTE:** Unit nameplate states maximum current draw. Maximum over current protection allowed is shown in Table 12.

2. Holes are on both sides of the furnace cabinet to facilitate wiring.
3. Install a separate (properly sized) disconnect switch near the furnace so that power can be turned off for servicing.

Model	Maximum Over-Current Protection (Amps)
070-12	15
090-16, 110-20	20

Table 12

4. Before connecting the thermostat wiring, check to make sure the wires will be long enough for servicing at a later date. Remove the blower access panel to check the length of the wire.
5. Complete the wiring connections to the equipment. Use the provided unit wiring diagram and the field wiring diagram shown in Figures 24 and 25. Use 18 gauge wire or larger that is suitable for Class II rating for thermostat connections.
6. Electrically ground the unit according to local codes or, in the absence of local codes, according to the current National Electric Code (ANSI/NFPA No. 70). A green ground wire is provided in the field make-up box.

**NOTE:** *This furnace contains electronic components that are polarity sensitive. Make sure that the furnace is wired correctly and is properly grounded.*

7. One line voltage "AAC" 1/4" spade terminal is provided on the furnace integrated control. Any electronic air cleaner or other accessory rated up to one amp can be connected to this terminal with the neutral leg of the circuit being connected to one of the provided neutral terminals. See Figure 26 for control configuration. This terminal is energized when the indoor blower is operating.
8. An unpowered, normally open (dry) set of contacts with a 1/4" spade terminal "HUM" are provided for humidifier connections and may be connected to 24V or 120V. Any humidifier rated up to one amp can be connected to these terminals. In 120V humidifier applications the neutral leg of the circuit can be connected to one of the provided neutral terminals, the terminal is energized in the heating mode.
9. Install the room thermostat according to the instructions provided with the thermostat. If the furnace is being matched with a heat pump, refer to the instruction packaged with the dual fuel thermostat.

### Thermostat Selection



Field wiring for both communicating and non-communicating applications is illustrated in diagrams, which begins on Page 24.

### Non-Communicating

In non-communication applications this furnace is designed to operate in a SINGLE-STAGE mode or TWO-STAGE mode using a convention thermostat.

For optimal performance in non-communicating applications, use a high quality electronic digital thermostat or any other with adjustable settings for 1st stage / 2nd stage ON/OFF differentials and adjustable stage timers.

### Communicating

In communicating applications the Comfort Sync™ thermostat must be used. Refer to the instructions provided with the thermostat for installation, set-up and operation. In communicating systems all unused thermostat wire in the wire bundle needs to be terminated inside and out. The extra wires can terminate on the "C" terminal of the Comfort Sync™ communication terminal strip. Using an additional wire come off "C" terminal and wire nut all the extra wires together. Termination on the outdoor control must match the indoor control.

### Indoor Blower Speeds

#### Non-Communicating

When the thermostat is set to "FAN ON", the indoor blower will run continuously at approximately 38% of the second stage cooling speed when there is no cooling or heating demand.

When the furnace is running in the heating mode, the indoor blower will run on the heating speed designated by the positions of DIP switches 11, 12 and 13.

When there is a cooling demand, the indoor blower will run on the cooling speed designated by the positions of DIP switches 5 and 6. First stage cooling will run at 70% cool speed.

#### Communicating

**NOTE:** *When this furnace is used with a Comfort Sync™ thermostat, proper indoor blower speed selections are made by the communicating thermostat.*

When the thermostat is set to "FAN ON", the indoor blower will run at setting determined during system configuration.

When there is a heating demand the fan will run on heating speeds for firing rate.

When there is a cooling demand, the fan will run on the first stage and second stage cooling speed set using the Comfort Sync™ thermostat in the installer setup mode. The factory default is based upon 400 CFM per ton.

## Generator Use - Voltage Requirements

The following requirements must be kept in mind when specifying a generator for use with this equipment:

- The furnace requires 120 volts (Range: 102 volts to 132 volts).
- The furnace operates at 60 Hz  $\pm$  5% (Range: 57 Hz to 63 Hz).
- The furnace integrated control requires both correct polarity and proper ground. Both polarity and proper grounding should be checked before attempting to operate the furnace on either permanent or temporary power.
- Generator should have a wave form distortion of less than 5% THD (Total Harmonic Distortion).

## Electrical Wiring



Risk of electrical shock. Disconnect electrical power at the circuit breaker or service panel before making electrical connections. Failure to disconnect power supplies can result in property damage, personal injury, or death.

The furnace must be grounded and wired in accordance with local codes or, in the absence of local codes, with the National Electrical Code ANSI/NFPA No. 70 (latest edition) and/or CSA C22.1 Electrical Code (latest edition) if an external electrical source is utilized.

In all instances, other than wiring for the thermostat, the wiring to be done and any replacement of wire shall conform with the temperature limitation for Type T wire -63°F (35°C) rise.

Connect a sufficiently sized wire with ground to the furnace's line voltage connections and ground wire. Refer to the furnace rating plate for electrical characteristics to be used in sizing field supply wiring and overcurrent protection.

The line voltage supply should be routed through a readily accessible disconnect located within sight of the furnace. A junction box on the furnace side panel is provided for line voltage connections. Refer to the furnace wiring diagram for specific connection information.

Proper polarity of the supply connections ("HOT" and "NEUTRAL") must be observed to ensure that safety controls provide the protection intended.

A connection to the unit's ground wire and actual earth ground (typically a ground stake or buried steel pipe) must be maintained for proper operation.

Comfort Sync™ Thermostat  
 Comfort Sync™ Enabled Indoor Furnace  
 Non-Communicating Outdoor Air Conditioner

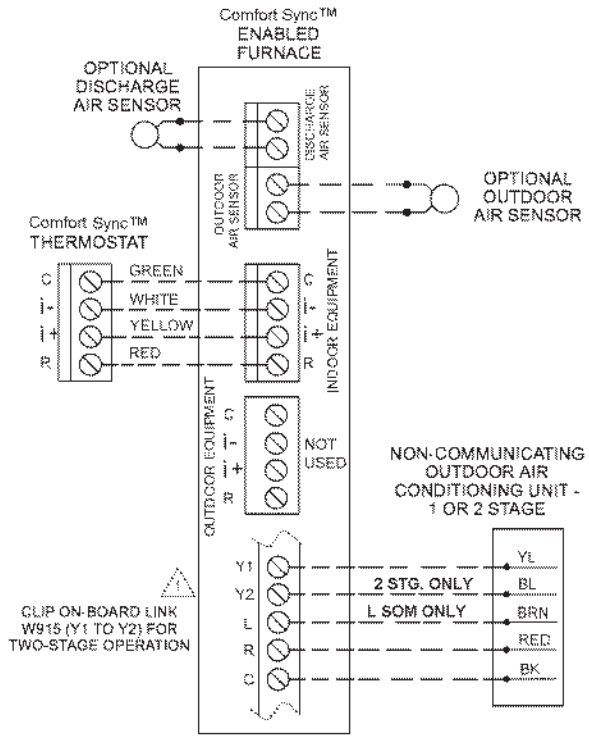

Comfort Sync™ Thermostat  
 Comfort Sync™ Enabled Indoor Furnace  
 Comfort Sync™ Enabled Outdoor Air Conditioner or Heat Pump

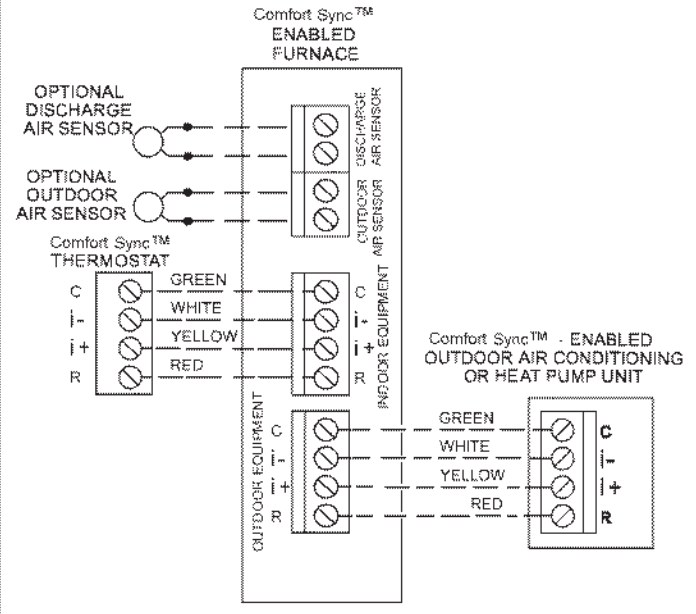

Non-Communicating Outdoor Air Conditioner

NOTE - On communicating systems, extra wires must terminate on the "C" Comfort Sync™ terminal strip (RSBus). Use an additional wire and come off "C" terminal and wire nut all the extra wires together. Termination on the outdoor control must match the indoor control.

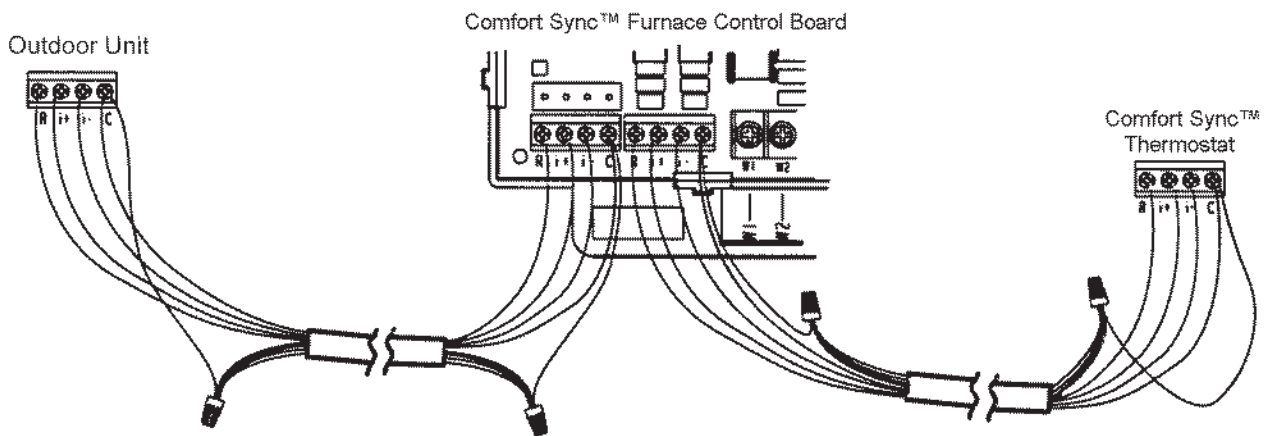

Figure 22



## Optional Accessories for use with any Comfort Sync™ System

**NOTE:** Comfort Sync™ Thermostat senses humidity & controls HUM contacts to cycle humidifier based on demand. No other control or humidistat required.

Optional outdoor air sensor for use with humidifier (if not already in the system for other functions. Built into all Comfort Sync™ enabled outdoor units).

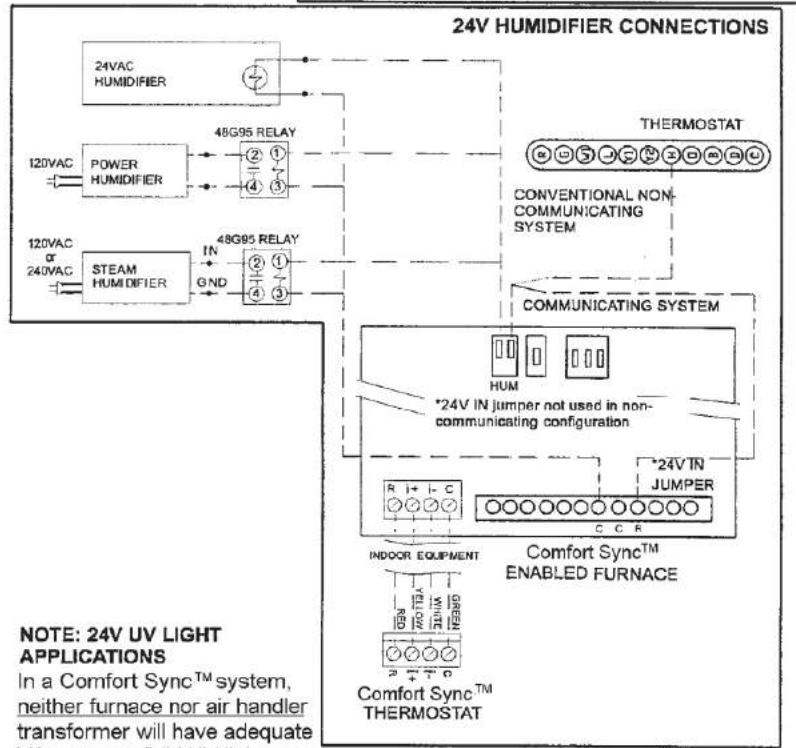
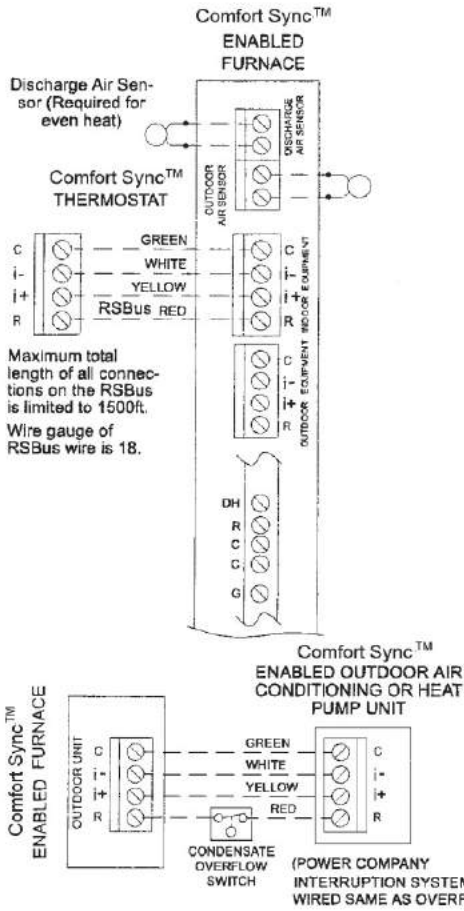

**NOTE: 24V UV LIGHT APPLICATIONS**  
In a Comfort Sync™ system, neither furnace nor air handler transformer will have adequate VA to power 24V UV light applications. An additional transformer for UV light applications is required.

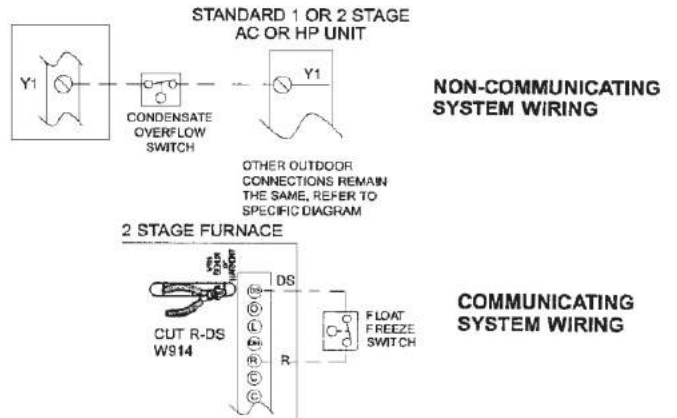
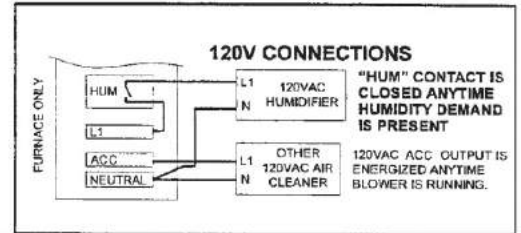
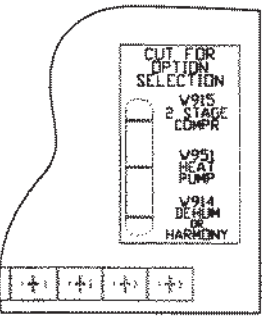
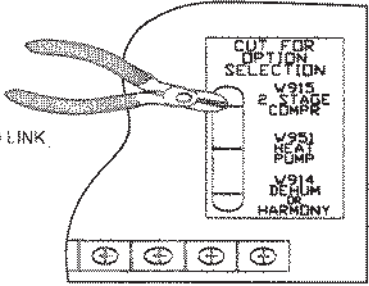
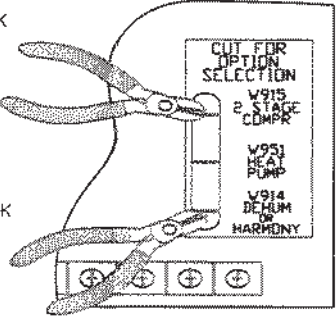

Figure 23

### Field Wiring Applications with Conventional Thermostat

Thermostat	DIP Switch Settings and On-Board Links		Wiring Connections																														
	DIP Switch 1 Thermostat Heating Stages	On Board Links Must Be Cut To Select System Options																															
<p>1 Heat / 1 Cool</p> <p><i>NOTE - Use DIP switch 2 to set second-stage heat ON delay. OFF-7 minutes. ON-12 minutes.</i></p>	ON	<p>DO NOT CUT ANY ON-BOARD LINKS</p> 	<table style="width: 100%; border-collapse: collapse;"> <thead> <tr> <th style="width: 25%;">S1 T'STAT</th> <th style="width: 25%;">FURNACE TERM. STRIP</th> <th style="width: 50%;">OUTDOOR UNIT</th> </tr> </thead> <tbody> <tr> <td></td> <td style="text-align: center;">DB</td> <td></td> </tr> <tr> <td style="text-align: center;">W2</td> <td style="text-align: center;">W2</td> <td></td> </tr> <tr> <td style="text-align: center;">W1</td> <td style="text-align: center;">W1</td> <td></td> </tr> <tr> <td style="text-align: center;">R</td> <td style="text-align: center;">R</td> <td style="text-align: center;">* R</td> </tr> <tr> <td style="text-align: center;">G</td> <td style="text-align: center;">G</td> <td></td> </tr> <tr> <td style="text-align: center;">C</td> <td style="text-align: center;">C</td> <td style="text-align: center;">C</td> </tr> <tr> <td></td> <td style="text-align: center;">Y2</td> <td></td> </tr> <tr> <td style="text-align: center;">Y</td> <td style="text-align: center;">Y1</td> <td style="text-align: center;">Y1</td> </tr> <tr> <td></td> <td style="text-align: center;">O</td> <td></td> </tr> </tbody> </table>	S1 T'STAT	FURNACE TERM. STRIP	OUTDOOR UNIT		DB		W2	W2		W1	W1		R	R	* R	G	G		C	C	C		Y2		Y	Y1	Y1		O	
S1 T'STAT	FURNACE TERM. STRIP	OUTDOOR UNIT																															
	DB																																
W2	W2																																
W1	W1																																
R	R	* R																															
G	G																																
C	C	C																															
	Y2																																
Y	Y1	Y1																															
	O																																
<p>1 Heat / 2 Cool</p> <p><i>NOTE - Use DIP switch 2 to set second-stage heat ON delay. OFF-7 minutes. ON-12 minutes.</i></p>	ON	<p>CUT ON-BOARD LINK, W915 2 STAGE COMPR</p> 	<table style="width: 100%; border-collapse: collapse;"> <thead> <tr> <th style="width: 25%;">S1 T'STAT</th> <th style="width: 25%;">FURNACE TERM. STRIP</th> <th style="width: 50%;">OUTDOOR UNIT</th> </tr> </thead> <tbody> <tr> <td></td> <td style="text-align: center;">DB</td> <td></td> </tr> <tr> <td></td> <td style="text-align: center;">W2</td> <td></td> </tr> <tr> <td style="text-align: center;">W</td> <td style="text-align: center;">W1</td> <td></td> </tr> <tr> <td style="text-align: center;">R</td> <td style="text-align: center;">R</td> <td style="text-align: center;">* R</td> </tr> <tr> <td style="text-align: center;">G</td> <td style="text-align: center;">G</td> <td></td> </tr> <tr> <td style="text-align: center;">C</td> <td style="text-align: center;">C</td> <td style="text-align: center;">C</td> </tr> <tr> <td style="text-align: center;">Y2</td> <td style="text-align: center;">Y2</td> <td style="text-align: center;">Y2</td> </tr> <tr> <td style="text-align: center;">Y1</td> <td style="text-align: center;">Y1</td> <td style="text-align: center;">Y1</td> </tr> <tr> <td></td> <td style="text-align: center;">O</td> <td></td> </tr> </tbody> </table>	S1 T'STAT	FURNACE TERM. STRIP	OUTDOOR UNIT		DB			W2		W	W1		R	R	* R	G	G		C	C	C	Y2	Y2	Y2	Y1	Y1	Y1		O	
S1 T'STAT	FURNACE TERM. STRIP	OUTDOOR UNIT																															
	DB																																
	W2																																
W	W1																																
R	R	* R																															
G	G																																
C	C	C																															
Y2	Y2	Y2																															
Y1	Y1	Y1																															
	O																																
<p>1 Heat / 2 Cool with t'stat with humidity control</p> <p><i>NOTE - Use DIP switch 2 to set second-stage heat ON delay. OFF-7 minutes. ON-12 minutes.</i></p>	ON	<p>CUT ON-BOARD LINK W915 2 STAGE COMPR</p> <p>CUT ON-BOARD LINK W914 DEHUM OR HARMONY</p> 	<table style="width: 100%; border-collapse: collapse;"> <thead> <tr> <th style="width: 25%;">S1 T'STAT</th> <th style="width: 25%;">FURNACE TERM. STRIP</th> <th style="width: 50%;">OUTDOOR UNIT</th> </tr> </thead> <tbody> <tr> <td style="text-align: center;">DB</td> <td style="text-align: center;">DB</td> <td></td> </tr> <tr> <td></td> <td style="text-align: center;">W2</td> <td></td> </tr> <tr> <td style="text-align: center;">W1</td> <td style="text-align: center;">W1</td> <td></td> </tr> <tr> <td style="text-align: center;">R</td> <td style="text-align: center;">R</td> <td style="text-align: center;">* R</td> </tr> <tr> <td style="text-align: center;">G</td> <td style="text-align: center;">G</td> <td></td> </tr> <tr> <td style="text-align: center;">C</td> <td style="text-align: center;">C</td> <td style="text-align: center;">C</td> </tr> <tr> <td style="text-align: center;">Y2</td> <td style="text-align: center;">Y2</td> <td style="text-align: center;">Y2</td> </tr> <tr> <td style="text-align: center;">Y1</td> <td style="text-align: center;">Y1</td> <td style="text-align: center;">Y1</td> </tr> <tr> <td></td> <td style="text-align: center;">O</td> <td></td> </tr> </tbody> </table>	S1 T'STAT	FURNACE TERM. STRIP	OUTDOOR UNIT	DB	DB			W2		W1	W1		R	R	* R	G	G		C	C	C	Y2	Y2	Y2	Y1	Y1	Y1		O	
S1 T'STAT	FURNACE TERM. STRIP	OUTDOOR UNIT																															
DB	DB																																
	W2																																
W1	W1																																
R	R	* R																															
G	G																																
C	C	C																															
Y2	Y2	Y2																															
Y1	Y1	Y1																															
	O																																

\* Not required on all units.

Table 13A

**Field Wiring Applications with Conventional Thermostat (continued)**

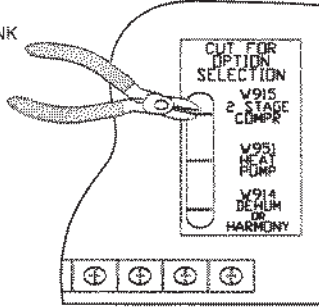
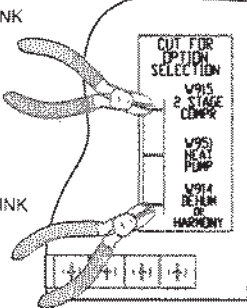
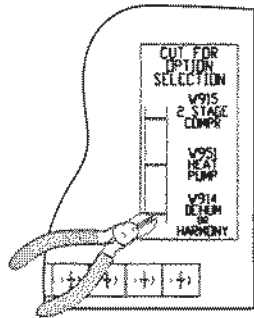
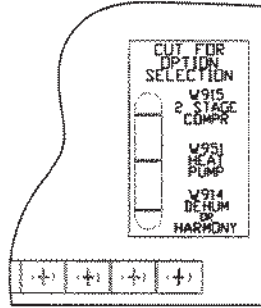
Thermostat	DIP Switch Settings and On-Board Links		Wiring Connections																														
	DIP Switch 1 Thermostat Heating Stages	On Board Links Must Be Cut To Select System Options																															
2 Heat / 2 Cool	OFF	<p>CUT ON-BOARD LINK W915 2 STAGE COMPR</p> 	<table border="0"> <tr> <td>S1 T'STAT</td> <td>FURNACE TERM. STRIP</td> <td>OUTDOOR UNIT</td> </tr> <tr> <td>(DB)</td> <td>(DB)</td> <td></td> </tr> <tr> <td>(W2)-----</td> <td>(W2)</td> <td></td> </tr> <tr> <td>(W1)-----</td> <td>(W1)</td> <td></td> </tr> <tr> <td>(R)-----</td> <td>(R)-----*</td> <td>(R)</td> </tr> <tr> <td>(G)-----</td> <td>(G)</td> <td></td> </tr> <tr> <td>(C)-----</td> <td>(C)</td> <td>(C)</td> </tr> <tr> <td>(Y2)-----</td> <td>(Y2)</td> <td>(Y2)</td> </tr> <tr> <td>(Y1)-----</td> <td>(Y1)</td> <td>(Y1)</td> </tr> <tr> <td></td> <td>(O)</td> <td></td> </tr> </table>	S1 T'STAT	FURNACE TERM. STRIP	OUTDOOR UNIT	(DB)	(DB)		(W2)-----	(W2)		(W1)-----	(W1)		(R)-----	(R)-----*	(R)	(G)-----	(G)		(C)-----	(C)	(C)	(Y2)-----	(Y2)	(Y2)	(Y1)-----	(Y1)	(Y1)		(O)	
S1 T'STAT	FURNACE TERM. STRIP	OUTDOOR UNIT																															
(DB)	(DB)																																
(W2)-----	(W2)																																
(W1)-----	(W1)																																
(R)-----	(R)-----*	(R)																															
(G)-----	(G)																																
(C)-----	(C)	(C)																															
(Y2)-----	(Y2)	(Y2)																															
(Y1)-----	(Y1)	(Y1)																															
	(O)																																
2 Heat / 2 Cool with t'stat with humidity control	OFF	<p>CUT ON-BOARD LINK W915 2 STAGE COMPR</p> <p>CUT ON-BOARD LINK W914 DEHUM OR HARMONY</p> 	<table border="0"> <tr> <td>S1 T'STAT</td> <td>FURNACE TERM. STRIP</td> <td>OUTDOOR UNIT</td> </tr> <tr> <td>(DB)-----</td> <td>(DB)</td> <td></td> </tr> <tr> <td>(W2)-----</td> <td>(W2)</td> <td></td> </tr> <tr> <td>(W1)-----</td> <td>(W1)</td> <td></td> </tr> <tr> <td>(R)-----</td> <td>(R)-----*</td> <td>(R)</td> </tr> <tr> <td>(G)-----</td> <td>(G)</td> <td></td> </tr> <tr> <td>(C)-----</td> <td>(C)</td> <td>(C)</td> </tr> <tr> <td>(Y2)-----</td> <td>(Y2)</td> <td>(Y2)</td> </tr> <tr> <td>(Y1)-----</td> <td>(Y1)</td> <td>(Y1)</td> </tr> <tr> <td></td> <td>(O)</td> <td></td> </tr> </table>	S1 T'STAT	FURNACE TERM. STRIP	OUTDOOR UNIT	(DB)-----	(DB)		(W2)-----	(W2)		(W1)-----	(W1)		(R)-----	(R)-----*	(R)	(G)-----	(G)		(C)-----	(C)	(C)	(Y2)-----	(Y2)	(Y2)	(Y1)-----	(Y1)	(Y1)		(O)	
S1 T'STAT	FURNACE TERM. STRIP	OUTDOOR UNIT																															
(DB)-----	(DB)																																
(W2)-----	(W2)																																
(W1)-----	(W1)																																
(R)-----	(R)-----*	(R)																															
(G)-----	(G)																																
(C)-----	(C)	(C)																															
(Y2)-----	(Y2)	(Y2)																															
(Y1)-----	(Y1)	(Y1)																															
	(O)																																
2 Heat / 1 Cool with t'stat with humidity control	OFF	<p>CUT ON-BOARD LINK W914 DEHUM OR HARMONY</p> 	<table border="0"> <tr> <td>S1 T'STAT</td> <td>FURNACE TERM. STRIP</td> <td>OUTDOOR UNIT</td> </tr> <tr> <td>(DB)-----</td> <td>(DB)</td> <td></td> </tr> <tr> <td>(W2)-----</td> <td>(W2)</td> <td></td> </tr> <tr> <td>(W1)-----</td> <td>(W1)</td> <td></td> </tr> <tr> <td>(R)-----</td> <td>(R)-----*</td> <td>(R)</td> </tr> <tr> <td>(G)-----</td> <td>(G)</td> <td></td> </tr> <tr> <td>(C)-----</td> <td>(C)</td> <td>(C)</td> </tr> <tr> <td>(Y1)-----</td> <td>(Y1)</td> <td>(Y1)</td> </tr> <tr> <td></td> <td>(O)</td> <td></td> </tr> </table>	S1 T'STAT	FURNACE TERM. STRIP	OUTDOOR UNIT	(DB)-----	(DB)		(W2)-----	(W2)		(W1)-----	(W1)		(R)-----	(R)-----*	(R)	(G)-----	(G)		(C)-----	(C)	(C)	(Y1)-----	(Y1)	(Y1)		(O)				
S1 T'STAT	FURNACE TERM. STRIP	OUTDOOR UNIT																															
(DB)-----	(DB)																																
(W2)-----	(W2)																																
(W1)-----	(W1)																																
(R)-----	(R)-----*	(R)																															
(G)-----	(G)																																
(C)-----	(C)	(C)																															
(Y1)-----	(Y1)	(Y1)																															
	(O)																																
2 Heat / 1 Cool	OFF	<p>DO NOT CUT ANY ON-BOARD LINKS</p> 	<table border="0"> <tr> <td>S1 T'STAT</td> <td>FURNACE TERM. STRIP</td> <td>OUTDOOR UNIT</td> </tr> <tr> <td>(DB)-----</td> <td>(DB)</td> <td></td> </tr> <tr> <td>(W2)-----</td> <td>(W2)</td> <td></td> </tr> <tr> <td>(W1)-----</td> <td>(W1)</td> <td></td> </tr> <tr> <td>(R)-----</td> <td>(R)-----*</td> <td>(R)</td> </tr> <tr> <td>(G)-----</td> <td>(G)</td> <td></td> </tr> <tr> <td>(C)-----</td> <td>(C)</td> <td>(C)</td> </tr> <tr> <td></td> <td>(Y2)</td> <td></td> </tr> <tr> <td>(Y)-----</td> <td>(Y1)</td> <td>(Y1)</td> </tr> <tr> <td></td> <td>(O)</td> <td></td> </tr> </table>	S1 T'STAT	FURNACE TERM. STRIP	OUTDOOR UNIT	(DB)-----	(DB)		(W2)-----	(W2)		(W1)-----	(W1)		(R)-----	(R)-----*	(R)	(G)-----	(G)		(C)-----	(C)	(C)		(Y2)		(Y)-----	(Y1)	(Y1)		(O)	
S1 T'STAT	FURNACE TERM. STRIP	OUTDOOR UNIT																															
(DB)-----	(DB)																																
(W2)-----	(W2)																																
(W1)-----	(W1)																																
(R)-----	(R)-----*	(R)																															
(G)-----	(G)																																
(C)-----	(C)	(C)																															
	(Y2)																																
(Y)-----	(Y1)	(Y1)																															
	(O)																																

\* Not required on all units.

**Table 13B**

Field Wiring Applications with Conventional Thermostat (continued)

Thermostat	DIP Switch Settings and On-Board Links		Wiring Connections
	DIP Switch 1 Thermostat Heating Stages	On Board Links Must Be Cut To Select System Options	
Dual Fuel Single Stage Heat Pump	OFF	<p>CUT ON-BOARD LINK W951 HEAT PUMP</p>	<p>L7742U T'STAT      FURNACE TERM. STRIP      HEAT PUMP</p> <p>R --- R --- R</p> <p>H --- H</p> <p>W2 --- W2</p> <p>W1 --- W1</p> <p>O --- O --- O</p> <p>Y1 --- Y1 --- Y</p> <p>Y2 --- Y2</p> <p>G --- G</p> <p>D --- D</p> <p>B --- B</p> <p>C --- C --- C</p> <p>T --- T</p> <p>T --- outdoor sensor</p>
Dual Fuel Two Stage Heat Pump	OFF	<p>CUT ON-BOARD LINK W915 2 STAGE COMPR</p> <p>CUT ON-BOARD LINK W951 HEAT PUMP</p>	<p>L7742U T'STAT      FURNACE TERM. STRIP      HEAT PUMP</p> <p>R --- R --- R</p> <p>H --- H</p> <p>W2 --- W2</p> <p>W1 --- W1</p> <p>O --- O --- O</p> <p>Y1 --- Y1 --- Y1</p> <p>Y2 --- Y2 --- Y2</p> <p>G --- G</p> <p>D --- D</p> <p>B --- B</p> <p>C --- C --- C</p> <p>T --- T</p> <p>T --- outdoor sensor</p> <p>Y2 out blue</p>

Table 13C

**Field Wiring Applications with Conventional Thermostat (continued)**

Thermostat	DIP Switch Settings and On-Board Links		Wiring Connections
	DIP Switch 1 Thermostat Heating Stages	On Board Links Must Be Cut To Select System Options	
Dual Fuel Two Stage Heat Pump with humidity control feature	OFF	<p>CUT ON-BOARD LINK W951 HEAT PUMP</p> <p>CUT ON-BOARD LINK W914 DEHUM OR HARMONY</p>	<p>L7742U T'STAT</p> <p>FURNACE TERM. STRIP</p> <p>HEAT PUMP</p> <p>R --- R --- R</p> <p>H --- W2 --- W1</p> <p>W2 --- W1</p> <p>O --- O --- O</p> <p>Y1 --- Y1 --- Y</p> <p>Y2 --- Y2</p> <p>G --- G</p> <p>D --- DB</p> <p>B --- Y2</p> <p>C --- C --- C</p> <p>T --- outdoor sensor</p> <p>T</p>
Dual Fuel Two Stage Heat Pump with humidity control feature	OFF	<p>CUT ON-BOARD LINK W915 2 STAGE COMPR</p> <p>CUT ON-BOARD LINK W951 HEAT PUMP</p> <p>CUT ON-BOARD LINK W914 DEHUM OR HARMONY</p>	<p>L7742U T'STAT</p> <p>FURNACE TERM. STRIP</p> <p>HEAT PUMP</p> <p>R --- R --- R</p> <p>H --- W2 --- W1</p> <p>W2 --- W1</p> <p>O --- O --- O</p> <p>Y1 --- Y1 --- Y1</p> <p>Y2 --- Y2</p> <p>G --- G</p> <p>D --- DB</p> <p>B --- Y2 --- Y2 out blue</p> <p>C --- C --- C</p> <p>T --- outdoor sensor</p> <p>T</p>

**Table 13D**

# A80DS2V Schematic Wiring Diagram

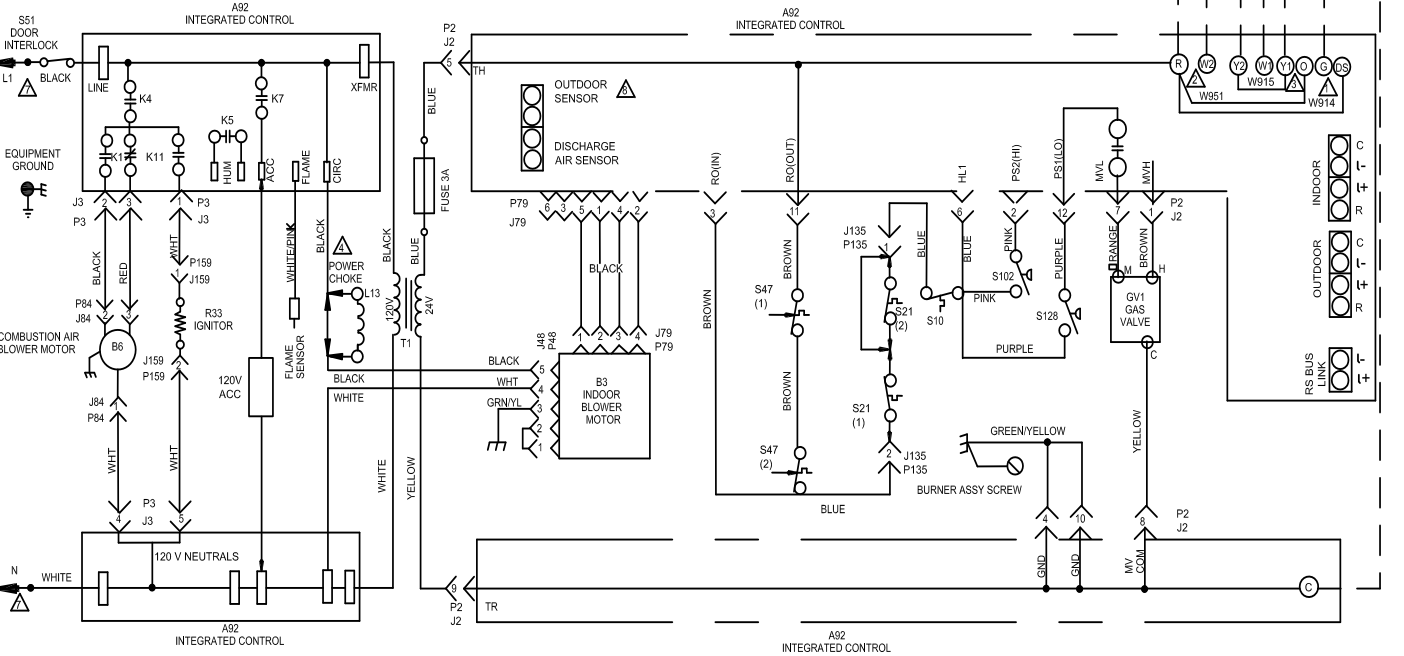
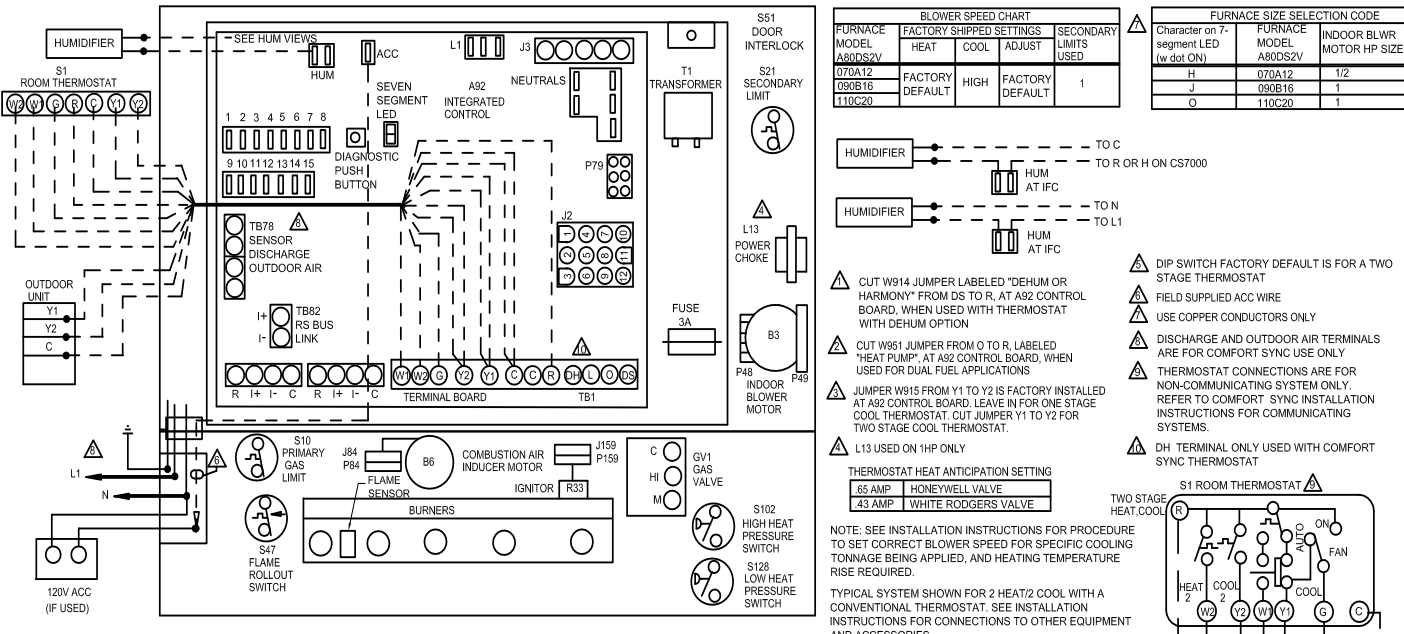

Figure 24

### Typical A80DS2V Field Wiring Diagram

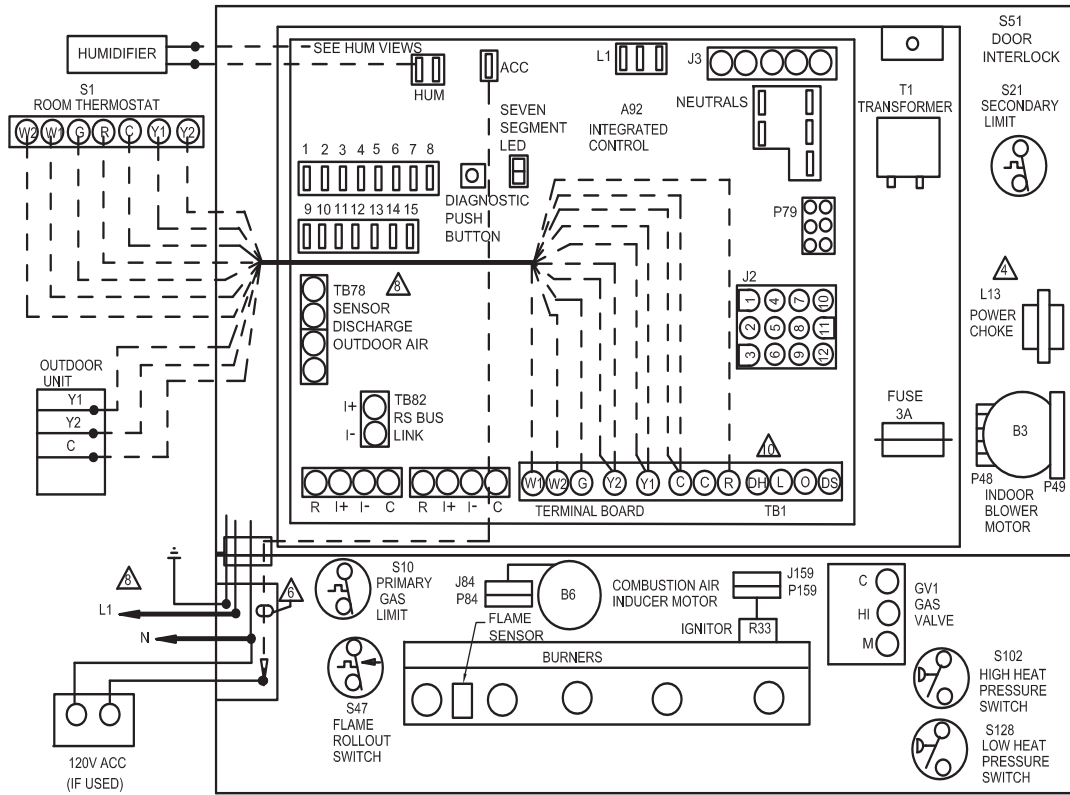
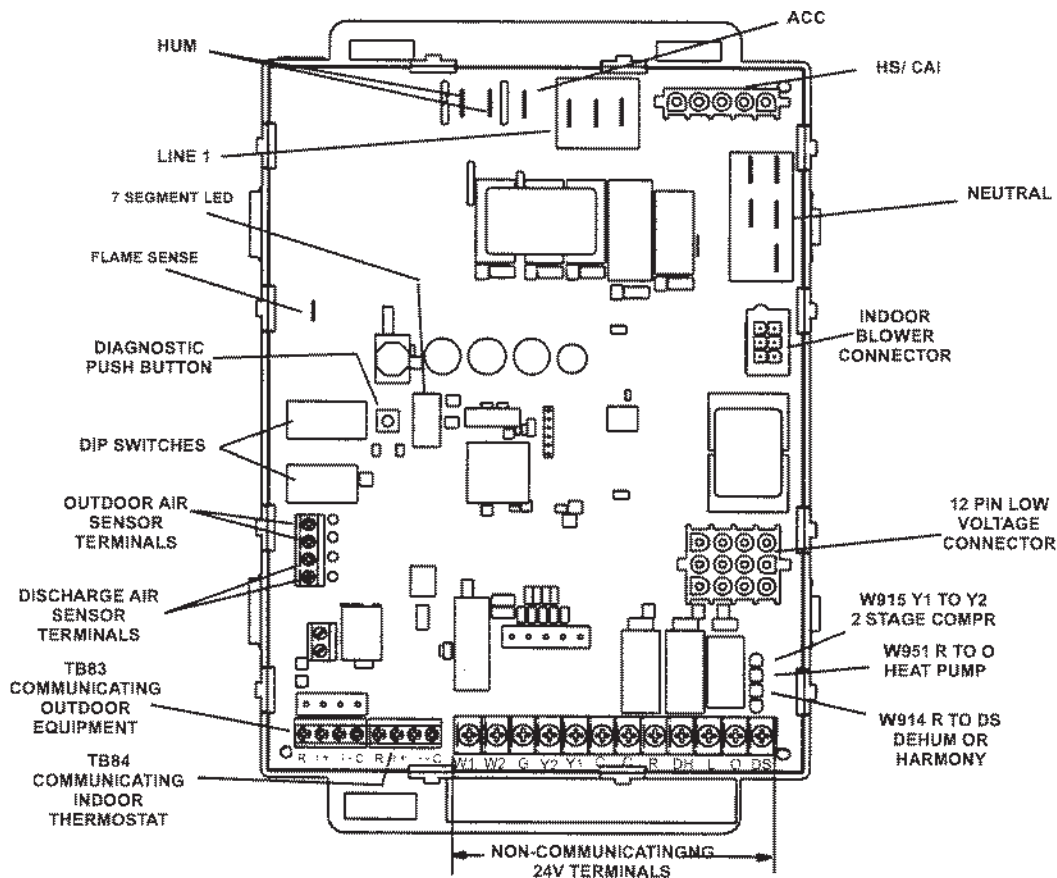

Figure 25

## Integrated Control



### RS-BUS LINK (TB82, future use)

I+ = DATA HIGH CONNECTION  
I- = DATA LOW CONNECTION

### RS-BUS OUTDOOR (TB83)

R = 24VAC  
I+ = DATA HIGH CONNECTION  
I- = DATA LOW CONNECTION  
C = 24VAXC COMMON

### RS-BUS INDOOR (TB84)

R = 24VAC  
I+ = DATA HIGH CONNECTION  
I- = DATA LOW CONNECTION  
C = 24VAXC COMMON

### 1/4" QUICK CONNECT TERMINALS

HUM = UNPOWERED NORMALLY OPEN (DRY) CONTACTS  
XMFR = 120 VAC OUTPUT TO TRANSFORMER  
LI = 120 VAC INPUT TO CONTROL  
ACC = 120 VAC OUTPUT TO OPTIONAL ACCESSORY  
NEUTRALS = 120 VAC NEUTRAL

### THERMOSTAT CONNECTIONS (TB1)

W1 = HEAT DEMAND FROM 1ST STAGE T/STAT  
W2 = HEAT DEMAND FROM 2ND STAGE T/STAT  
G = MANUAL FAN FROM T'STAT  
Y2 = THERMOSTAT 2ND STAGE COOL SIGNAL  
Y1 = THERMOSTAT 1ST STAGE COOL SIGNAL  
C = THERMOSTAT SIGNAL GROUND CONNECTED TO TRANSFORMER GRD (TR) & CHASIS GROUND (GRD)  
R = CLASS 2 VOLTAGE TO THERMOSTAT  
DH = DEHUMIDIFICATION OUTPUT COMMUNICATING THERMOSTAT ONLY  
L = USE ONLY WITH A COMMUNICATING THERMOSTAT AND A NON-COMMUNICATING OUTDOOR UNIT  
O = THERMOSTAT SIGNAL TO HEAT PUMP REVERSING VALVE  
DS = DEHUMIDIFICATION SIGNAL

Figure 26



## Integrated Control DIP Switch Settings - Conventional Thermostat (non-communicating)

This furnace is equipped with a two-stage, variable speed integrated control. This control manages ignition timing, heating mode fan off delays and indoor blower speeds based on selections made using the control dip switches and jumpers. The control includes an internal watchdog feature which automatically resets the ignition control when it has been locked out. After one hour of continuous thermostat demand for heat, the watchdog will break and remake thermostat demand to the furnace and automatically reset the control to relight the furnace.

**NOTE:** All Comfort Sync™ settings are set at the Comfort Sync™ thermostat. See Comfort Sync™ installation instruction. In Comfort Sync™ communication system all DIP switch and clippable link settings are ignored. For conventional thermostats proceed with DIP switch and clippable link settings as outlined in the following.

### Heating Operation DIP Switch Settings

**Switch 1 - Thermostat Selection** — This unit may be used with either a single-stage or two-stage thermostat. The thermostat selection is made using a DIP switch which must be properly positioned for the particular application. The DIP switch is factory-positioned for use with a two-stage thermostat. If a single-stage thermostat is to be used, the DIP switch must be repositioned.

Select “OFF” for two-stage heating operation controlled by a two-stage heating thermostat (factory setting);

Select “ON” for two-stage heating operation controlled by a single-stage heating thermostat. This setting provides a timed delay before second-stage heat is initiated.

### Switch 2 — Second Stage Delay

**(Used with Single-Stage Thermostat Only)** — This switch is used to determine the second stage on delay when a single-stage thermostat is being used. The switch is factory-set in the OFF position, which provides a 7-minute delay before second-stage heat is initiated. If the switch is toggled to the ON position, it will provide a 12-minute delay before second-stage heat is initiated. This switch is only activated when the thermostat selector jumper is positioned for SINGLE- stage thermostat use.

**Switches 3 and 4 — Blower-Off Delay** — The blower-ON delay of 30 seconds is not adjustable. The blower OFF delay (time that the blower operates after the heating demand has been satisfied) can be adjusted by moving switches 3 and 4 on the integrated control. The unit is shipped from the factory with a blower-OFF delay of 90 seconds. The blower OFF delay affects comfort and is adjustable to satisfy individual applications. Adjust the

blower OFF delay to achieve a supply air temperature between 90° and 110°F at the exact moment that the blower is de-energized. Longer OFF delay settings provide lower supply air temperatures; shorter settings provide higher supply air temperatures. Table 14 provides the blower OFF timings that will result from different switch settings.

**Blower OFF Delay Switch Settings**

Blower Off Delay (Seconds)	Switch 3	Switch 4
60	On	Off
90 (Factory)	Off	Off
120	Off	On
180	On	On

**Table 14**

### Indoor Blower Operation DIP Switch Settings Switches 5 and 6 — Cooling Mode Blower Speed

The unit is shipped from the factory with the dip switches positioned for high speed (4) indoor blower motor operation during the cooling mode. Table 15 provides the cooling mode blower speeds that will result from different switch settings. Switches 5 and 6 set the blower cfm for second-stage cool. The integrated control automatically ramps down to 70% of the second-stage cfm for first-stage cfm. Refer to tables for corresponding cfm values.

**Cooling Mode Blower Speeds**

Speed	Switch 5	Switch 6
Low	On	On
Medium Low	Off	On
Medium High	On	Off
High (Factory)	Off	Off

**Table 15**

### Switches 7 and 8 — Cooling Blower Speed Adjustment

The unit is shipped from the factory with the dip switches positioned for NORMAL (no) adjustment. The dip switches may be positioned to adjust the blower speed by +10% or -10% to better suit the application. Table 16 below provides blower speed adjustments that will result from different switch settings. Refer to tables for corresponding cfm values.

**Cooling Blower Speed Adjustment**

Adjustment	Switch 7	Switch 8
+10% (approx.)	On	Off
Factory Default	Off	Off
-10% (approx.)	Off	On

**Table 16**

### Switches 9 and 10 — Cooling Mode Blower Speed Ramping

Blower speed ramping may be used to enhance dehumidification performance. The switches are factory set at option A which has the greatest effect on dehumidification performance. Table 17 provides the cooling mode blower speed ramping options that will result from different switch settings. The cooling mode blower speed ramping options are detailed on the next page.

**NOTE:** The off portion of the selected ramp profile also applies during heat pump operation in dual fuel applications.

### Cooling Mode Blower Speed Ramping

Ramping Option	Switch 9	Switch 10
A (Factory)	Off	Off
B	Off	On
C	On	Off
D	On	On

Table 17

#### Ramping Option A (Factory Selection)

- Motor runs at 50% for 30 seconds.
- Motor then runs at 82% for approximately 7-1/2 minutes.
- If demand has not been satisfied after 7-1/2 minutes, motor runs at 100% until demand is satisfied.
- Once demand is met, motor runs at 50% for 30 seconds then ramps down to stop.

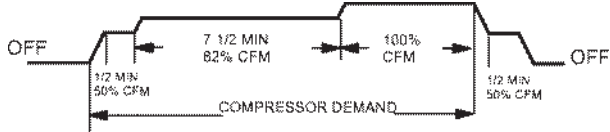

#### Ramping Option B

- Motor runs at 82% for approximately 7-1/2 minutes. If demand has not been satisfied after 7-1/2 minutes, motor runs at 100% until demand is satisfied.
- Once demand is met, motor ramps down to stop.



#### Ramping Option C

- Motor runs at 100% until demand is satisfied.
- Once demand is met, motor runs at 100% for 45 seconds then ramps down to stop.

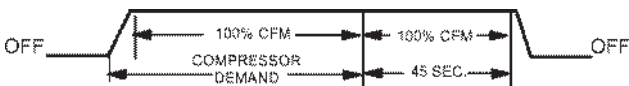

#### Ramping Option D

- Motor runs at 100% until demand is satisfied.
- Once demand is met, motor ramps down to stop.



#### Switches 11, 12 and 13 — Heating Mode Blower Speed

The switches are factory set to the OFF position which provides factory default heat speed. Refer to Table 18 for switches 11, 12 and 13 that provided the corresponding increases or decrease to both high and low heat demand.

#### Heating Mode Blower Speeds

Heat Speed	Switch 11	Switch 12	Switch 13
Increase 24%	On	On	On
Increase 18%	On	On	Off
Increase 12%	On	Off	On
Increase 6%	On	Off	Off
Factory Default	Off	Off	Off
Decrease 6%	Off	Off	On
Decrease 12%	Off	On	Off
Decrease 18%	Off	On	On

Table 18

## On-Board Links

**NOTE:** *In Comfort Sync™ systems with a conventional outdoor unit (non-communicating), the on-board clippable links must be set to properly configure the system.*



Carefully review all configuration information provided. Failure to properly set DIP switches, jumpers and on-board links can result in improper operation!

### On-Board Link W914 Dehum or Harmony (R to DS)

On-board link W914, is a clippable connection between terminals R and DS on the integrated control. W914 must be cut when the furnace is installed with a thermostat which features humidity control. If the link is left intact the PMW signal from the control will be blocked and also lead to control damage. Refer to Table 19 for operation sequence in applications including A80DS2V, a thermostat which features humidity control and a single-speed outdoor Unit. Table 20 gives the operation sequence in applications with a two-speed outdoor unit.

### On-Board Link W951 Heat Pump (R to O)

On-board link W951 is a clippable connection between terminals R and O on the integrated control. W951 must be cut when the furnace is installed in applications which include a heat pump unit and a thermostat which features dual fuel use. If the link is left intact, terminal "O" will remain energized eliminating the HEAT MODE in the heat pump.

### On-Board Link W915 2 Stage Compr (Y1 to Y2)

On-board link W915 is a clippable connection between terminals Y1 and Y2 on the integrated control. W915 must be cut if two-stage cooling will be used. If the Y1 to Y2 link is not cut, the outdoor unit will operate in second-stage cooling only.

### Diagnostic LED (Figure 26)

The seven-segment diagnostic LED displays operating status, target airflow, error codes and other information. A full listing of LED codes is provided in the Diagnostic Codes Section.

### Diagnostic Push Button (Figure 26)

The diagnostic push button is located adjacent to the seven-segment diagnostic LED. This button is used to enable the Error Code Recall "E" mode and the Flame Signal "F" mode. Press the button and hold it to cycle through a menu of options. Every five seconds a new menu item will be displayed. When the button is released, the displayed item will be selected. Once all items in the menu have been displayed, the menu resumes from the beginning until the button is released.

### Error Code Recall Mode

Select "E" from the menu to access the most recent 10 error codes. Select "c" from the Error Code Recall menu to clear all error codes. Button must be pressed a second time while "c" is flashing to confirm command to delete codes. Press the button until a solid "≡" is displayed to exit the Error Code Recall mode.

### Flame Signal Mode

Select "F" from the menu to access the flame signal mode. The integrated control will display the flame current on 7 segment LED in micro amps (uA).

Flame signal mode is exited after the following:

- Power is reset
- Pressing and holding push button until 3 horizontal lines "≡" are displayed
- 10 minutes of entering the flame sense mode.

**OPERATING SEQUENCE**  
**Non-Communicating Thermostat with Humidity Control Feature and Single-Speed Outdoor Unit**

OPERATING SEQUENCE		SYSTEM DEMAND						SYSTEM RESPONSE			
System Condition	Step	Thermostat Demand				Relative Humidity		Compressor	Blower CFM (COOL)	Comments	
		Y1	O	G	W 1	Status	D				
<i>NO CALL FOR DEHUMIDIFICATION</i>											
Normal Operation	1	On	On	On		Acceptable	24 VAC	High	100%	Compressor and indoor blower follow thermostat demand	
<i>BASIC MODE (only active on a Y1 thermostat demand)</i>											
Normal Operation	1	On	On	On		Acceptable	24 VAC	High	100%	Reverse logic dehumidification thermostat energizes Y1 and de-energizes D on a call for de-humidification	
Dehumidification Call	2	On	On	On		Demand	0 VAC	High	70%*		
<i>PRECISION MODE (operates independent of a Y1 thermostat demand)</i>											
Normal Operation	1	On	On	On		Acceptable	24 VAC	High	100%	Dehumidification mode begins when humidity is greater than set point	
Dehumidification call	2	On	On	On		Demand	0 VAC	High	70%*		
Dehumidification call ONLY	1	On	On	On		Demand	0 VAC	High	70%*	Reverse logic dehumidification thermostat will try to maintain room humidity setpoint by allowing the room space to maintain a cooler room thermostat setpoint**	
Jumpers at indoor unit with a single stage outdoor unit With Condensing unit - Cut W914 (R to DS) on furnace control With Heat Pump - Cut W914 (R to DS) & W951 (R to O) on furnace control											

\* Dehumidification blower speed is 70% of COOL speed for all units.

\*\* In Precision mode, thermostat will maintain room temperature up to 2°F (1.2°C) cooler than room setting.

**Table 19**

**OPERATING SEQUENCE**  
**Non-Communicating Thermostat with Humidity Control Feature and Two-Speed Outdoor Unit**

OPERATING SEQUENCE		SYSTEM DEMAND								SYSTEM RESPONSE		
System Condition	Step	Thermostat Demand						Relative Humidity		Compressor	Blower CFM (COOL)	Comments
		Y1	Y2	O	G	W 1	W 2	Status	D			
<b>NO CALL FOR DEHUMIDIFICATION</b>												
Normal Operation Y1	1	On		On	On			Acceptable	24 VAC	Low	70%*	Compressor and indoor blower follow thermostat demand
Normal Operation Y2	2	On	On	On	On			Acceptable	24 VAC	High	100%	
<b>ROOM THERMOSTAT CALLS FOR FIRST STAGE COOLING</b>												
<i>BASIC MODE (only active on a Y1 thermostat demand)</i>												
Normal Operation	1	On		On	On			Acceptable	24 VAC	Low	70%*	Reverse logic dehumidification thermostat energizes Y2 and de-energizes D on a call for de-humidification
Dehumidification Call	2	On	On	On	On			Demand	0 VAC	High	70%**	
<i>PRECISION MODE (operates independent of a Y1 thermostat demand)</i>												
Normal Operation	1	On		On	On			Acceptable	24 VAC	Low	70%*	Dehumidification mode begins when humidity is greater than set point
Dehumidification call	2	On	On	On	On			Demand	0 VAC	High	70%**	
Dehumidification call ONLY	1	On	On	On	On			Demand	0 VAC	High	70%**	Reverse logic dehumidification thermostat will try to maintain room humidity setpoint by allowing the room space to maintain a cooler room thermostat setpoint***
<b>ROOM THERMOSTAT CALLS FOR FIRST AND SECOND STAGE COOLING</b>												
<i>BASIC MODE (only active on a Y1 thermostat demand)</i>												
Normal Operation	1	On	On	On	On			Acceptable	24 VAC	High	100%	Reverse logic dehumidification thermostat energizes Y2 and de-energizes D on a call for de-humidification
Dehumidification Call	2	On	On	On	On			Demand	0 VAC	High	70%**	
<i>PRECISION MODE (operates independent of a Y1 thermostat demand)</i>												
Normal Operation	1	On		On	On			Acceptable	24 VAC	Low	70%*	Dehumidification mode begins when humidity is greater than set point
Dehumidification call	2	On	On	On	On			Demand	0 VAC	High	70%**	
Dehumidification call ONLY	1	On	On	On	On			Demand	0 VAC	High	70%**	Reverse logic dehumidification thermostat will try to maintain room humidity setpoint by allowing the room space to maintain a cooler room thermostat setpoint***
Jumpers at indoor unit with a two stage outdoor unit Cut factory jumper from Y1 to Y2 or cut W915 (Y1 to Y2) With Condensing unit - Cut W914 (R to DS) on furnace control With Heat Pump - Cut W914 (R to DS) & W951 (R to O) on furnace control												

\*Normal operation first stage cooling blower speed is 70% COOL speed.

\*\*Dehumidification blower speed is reduced to 70% of COOL.

\*\*\* In Precision Mode, thermostat will maintain room temperature up to 2°F (1.2°C) cooler than the set point.

**Table 20**

**BLOWER DATA****A80DS2V070A12 BLOWER PERFORMANCE (less filter)**

0 through 0.8 in. w.c. (Heating) and 0 through 1.0 in. w.c. (Cooling) External Static Pressure Range

**HEATING**

<sup>1</sup> Heating Speed DIP Switch Settings	First Stage Heating Speed - cfm		Second Stage Heating Speed - cfm	
24%		1040		1145
18%		990		1090
12%		940		1035
6%		890		980
Factory Default		840		925
-6%		790		870
-12%		740		815
-18%		690		760

**COOLING**

<sup>1</sup> Cooling Speed DIP Switch Settings	First Stage Cooling Speed - cfm				Second Stage Cooling Speed - cfm			
	Low	Medium-Low	Medium-High	<sup>2</sup> High	Low	Medium-Low	Medium-High	<sup>2</sup> High
10%	695	755	855	985	990	1080	1220	1410
Factory Default	630	685	775	895	900	980	1110	1280
-10%	565	615	700	805	810	880	1000	1150

<sup>1</sup> Cooling and heating speeds are based on a combination of DIP switch settings on the furnace control. Refer to installation instructions for specific DIP Switch Settings.

<sup>2</sup> Factory default settings.

NOTES- The effect of static pressure is included in air volumes shown.

First stage COOL (two-stage air conditioning units only) is approximately 70% of the same second stage COOL speed position.

Continuous Fan only speed is approximately 38% the selected second stage cooling speed - minimum 500 cfm.

**BLOWER DATA****A80DS2V090B16 BLOWER PERFORMANCE (less filter)**

0 through 0.8 in. w.c. (Heating) and 0 through 1.0 in. w.c. (Cooling) External Static Pressure Range

**HEATING**

<sup>1</sup> Heating Speed DIP Switch Settings	First Stage Heating Speed - cfm		Second Stage Heating Speed - cfm	
24%		1355		1490
18%		1285		1415
12%		1220		1345
6%		1155		1270
Factory Default		1090		1200
-6%		1025		1130
-12%		960		1055
-18%		895		985

**COOLING**

<sup>1</sup> Cooling Speed DIP Switch Settings	First Stage Cooling Speed - cfm				Second Stage Cooling Speed - cfm			
	Low	Medium-Low	Medium-High	<sup>2</sup> High	Low	Medium-Low	Medium-High	<sup>2</sup> High
10%	770	935	1075	1240	1100	1320	1540	1760
Factory Default	700	850	975	1125	1000	1200	1400	1600
-10%	630	765	880	1015	900	1080	1260	1440

<sup>1</sup> Cooling and heating speeds are based on a combination of DIP switch settings on the furnace control. Refer to installation instructions for specific DIP Switch Settings.

<sup>2</sup> Factory default settings.

NOTES- The effect of static pressure is included in air volumes shown.

First stage COOL (two-stage air conditioning units only) is approximately 70% of the same second stage COOL speed position.

Continuous Fan only speed is approximately 38% the selected second stage cooling speed - minimum 500 cfm.

**BLOWER DATA**

**A80DS2V110C20 BLOWER PERFORMANCE (less filter)**

0 through 0.8 in. w.c. (Heating) and 0 through 1.0 in. w.c. (Cooling) External Static Pressure Range

**HEATING**

<sup>1</sup> Heating Speed DIP Switch Settings	First Stage Heating Speed - cfm	Second Stage Heating Speed - cfm
24%	1580	1740
18%	1505	1660
12%	1430	1575
6%	1350	1490
Factory Default	1275	1405
-6%	1200	1320
-12%	1120	1235
-18%	1045	1150

**COOLING**

<sup>1</sup> Cooling Speed DIP Switch Settings	First Stage Cooling Speed - cfm				Second Stage Cooling Speed - cfm			
	Low	Medium-Low	Medium-High	<sup>2</sup> High	Low	Medium-Low	Medium-High	<sup>2</sup> High
10%	985	1140	1295	1330	1405	1625	1845	1900
Factory Default	895	1035	1175	1210	1275	1475	1675	1725
-10%	805	930	1060	1090	1150	1330	1510	1550

<sup>1</sup> Cooling and heating speeds are based on a combination of DIP switch settings on the furnace control. Refer to installation instructions for specific DIP Switch Settings.

<sup>2</sup> Factory default settings.

NOTES- The effect of static pressure is included in air volumes shown.

First stage COOL (two-stage air conditioning units only) is approximately 70% of the same second stage COOL speed position.

Continuous Fan only speed is approximately 38% the selected second stage cooling speed - minimum 500 cfm.

## START-UP

### For Your Safety, Read Before Operating

#### **WARNING**

Do not use this furnace if any part has been under water. Immediately call a licensed professional service technician (or equivalent) to inspect the furnace and to replace any part of the control system and any gas control which has been under water.

#### **WARNING**

If overheating occurs or if gas supply fails to shut off, shut off the manual gas valve to the appliance before shutting off electrical supply.

#### **CAUTION**

Before attempting to perform any service or maintenance, turn the electrical power to unit OFF at disconnect switch.

#### **WARNING**

During blower operation, the ECM motor emits energy that may interfere with pacemaker operation. Interference is reduced by both the sheet metal cabinet and distance.

**BEFORE LIGHTING** smell all around the appliance area for gas. Be sure to smell next to the floor because some gas is heavier than air and will settle on the floor.

The gas valve on this unit is equipped with a gas control switch. Use only your hand to move the switch. Never use tools. If the switch will not turn or if the control switch will not move by hand, do not try to repair it. Force or attempted repair may result in a fire or explosion.

#### Placing the furnace into operation:

These units are equipped with an automatic ignition system. Do not attempt to manually light burners on these furnaces. Each time the thermostat calls for heat, the burners will automatically light. The ignitor does not get hot when there is no call for heat on units with an automatic ignition system.

#### **WARNING**

If you do not follow these instructions exactly, a fire or explosion may result causing property damage, personal injury, or loss of life.

#### Gas Valve Operation (Figures 27 and 28)

1. STOP! Read the safety information at the beginning of this section.
2. Set the thermostat to the lowest setting.
3. Turn OFF all electrical power to the unit.
4. This furnace is equipped with an ignition device which automatically lights the burners. Do **not** try to light the burners by hand.
5. Remove the heating compartment access panel.
6. Move gas valve switch to **OFF** position. Do **not** force. See Figure 27 or 28.
7. Wait five (5) minutes to clear out any gas. If you then smell gas, **STOP!** Immediately call your gas supplier from a neighbor's phone. Follow the gas supplier's instructions. If you do not smell gas go to next step.

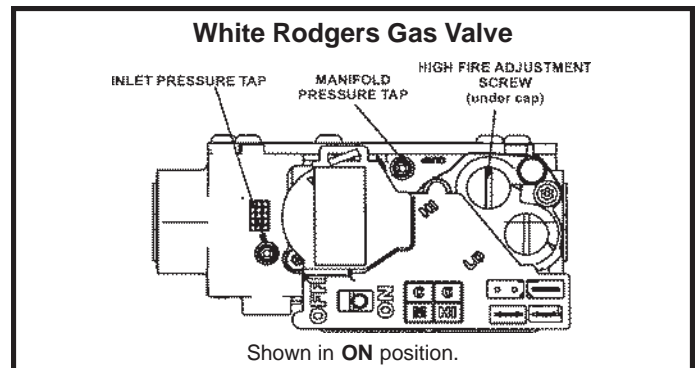

Figure 27

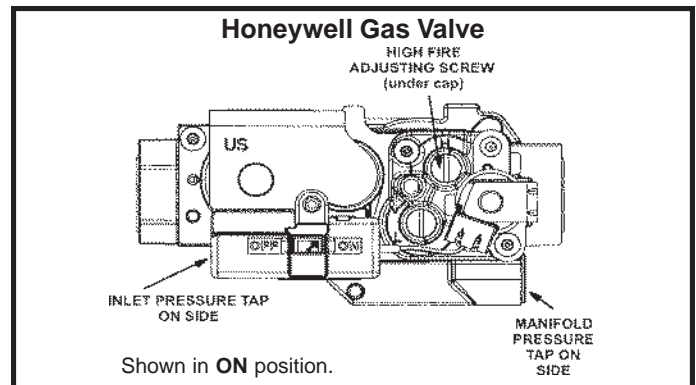

Figure 28

8. Move gas valve switch to **ON** position. Do **not** force. See Figures 27 or 28.
9. Replace the heating compartment access panel.
10. Turn **ON** all electrical power to the unit.
11. Set the thermostat to desired setting.

**NOTE:** When unit is initially started, steps 1 through 11 may need to be repeated to purge air from gas line.

12. If the appliance will not operate, follow the instructions "Turning Off Gas to Unit" and call your service technician or gas supplier.



## Turning Off Gas to Unit

1. Set the thermostat to the lowest setting.
2. Turn **off** all electrical power to the unit if service is to be performed.
3. Remove the heating compartment access panel.
4. Move gas valve switch to **OFF** position. Do **not** force. See Figure 27 or 28.
5. Replace the heating compartment access panel.

## Failure To Operate

If the unit fails to operate, check the following:

1. Is the thermostat calling for heat?
2. Are access panels securely in place?
3. Is the main disconnect switch closed?
4. Is there a blown fuse or tripped circuit breaker?
5. Is the filter dirty or plugged? Dirty or plugged filters will cause the limit control to shut the unit off.
6. Is gas turned on at the meter?
7. Is the manual main shut-off valve open?
8. Is the internal manual shut-off valve open?
9. Is the unit ignition system in lock out? If the unit locks out again, call the service technician to inspect the unit for blockages.
10. Is pressure switch closed? Obstructed flue will cause unit to shut off at pressure switch. Check flue and outlet for blockages.
11. Are flame rollout switches tripped? If flame rollout switches are tripped, call the service technician for inspection.

## Gas Flow (Approximate)

Furnace should operate at least 5 minutes before checking gas flow. Determine time in seconds for two revolutions of gas through the meter. (Two revolutions assures a more accurate time.) Divide by two and compare to time in Table 20 below. If manifold pressure matches Table 22 and rate is incorrect, check gas orifices for proper size and restriction. Remove temporary gas meter if installed.

**NOTE:** To obtain accurate reading, shut off all other gas appliances connected to meter.

GAS METER CLOCKING CHART				
SL280 Unit	Seconds for One Revolution			
	Natural		LP	
	1 cu ft Dial	2 cu ft Dial	1 cu ft Dial	2 cu ft DIAL
-045	80	160	200	400
-70	55	110	136	272
-90	41	82	102	204
-110	33	66	82	164
-135	27	54	68	136
Natural-1000 btu/cu ft		LP-2500 btu/cu ft		

**Table 20**

## Supply Pressure Measurement

### White Rodgers Valve:

An inlet post located on the gas valve provides access to the supply pressure. See Figure 27. Back out the 3/32 hex screw one turn, connect a piece of 5/16 tubing and connect to a manometer to measure supply pressure. See Table 22 for supply line pressure. Tighten hex screw after measurements have been taken.

### Honeywell Valve:

A threaded plug on the inlet side of the gas valve provides access to the supply pressure tap. Remove the threaded plug, install a field-provided barbed fitting and connect a manometer to measure supply pressure. See Table 22 for supply line pressure. Replace the threaded plug after measurements have been taken.

**NOTE:** Shut unit off and remove manometer as soon as an accurate reading has been obtained. Take care to replace pressure tap plug.

## Manifold Pressure Measurement

**NOTE:** A pressure test adapter kit is available to facilitate manifold pressure measurement.

1. Connect test gauge to manifold pressure post tap (Figure 27) or tap (Figure 28) on gas valve.
2. Ignite unit on high fire and let run for 5 minutes to allow for steady state conditions.
3. After allowing unit to stabilize for 5 minutes, record manifold pressure and compare to value given in Table 22.
4. If necessary, make adjustments. Figures 27 and 28 show location of high fire adjustment screw.
5. If an adjustment is made on high fire, re-check manifold pressure on low fire. **Do not adjust low fire manifold pressure.** If low fire manifold pressure is more than 1/2" above or below value specified in Table 22, replace valve.

**NOTE:** Shut unit off and remove manometer as soon as an accurate reading has been obtained. Take care to replace pressure tap plug.

## Proper Combustion

Furnace should operate minimum 15 minutes with correct manifold pressure and gas flow rate before checking combustion. Table 21 shows acceptable combustion for ALL models. The maximum carbon monoxide reading should not exceed 50 ppm.

Firing Rate	CO2% For Nat	CO2% For L.P.
High Fire	6.8 - 7.4	7.5 - 9.0
Low Fire	4.2 - 5.7	5.0 - 6.0

**Table 21**

## OPERATION

### High Altitude

The manifold pressure, gas orifice and pressure switch may require adjustment or replacement to ensure proper operation at higher altitudes. See Table 22 through 25 for manifold pressures, pressure switch and gas conversion kits at all altitudes.



### WARNING

For safety, shut unit OFF and remove manometer as soon as an accurate reading has been obtained. Take care to replace pressure tap plug.

### Manifold Pressure Settings

Unit Input	Gas	Orifice Size 0 - 7500 ft.	Orifice Size 7501 - 10,000 ft. <sup>1</sup>	Manifold Pressure in. w.g. 0-4500 ft.		Manifold Pressure in. w.g. 4501-7500 ft.		Manifold Pressure in. w.g. 7501 - 10,000 ft. <sup>2</sup>		Supply Line Pressure in. w.g.	
				Low Fire	High Fire	Low Fire	High Fire	Low Fire	High Fire	Min	Max
070	Natural	.063	.055	1.7	3.5	1.6	3.4	1.7	3.5	4.5	13.0
	LP/propane <sup>3</sup>	.039	.037	4.9	10.0	4.9	10.0	4.9	10.0	11.0	13.0
090	Natural	.063	.055	1.7	3.5	1.5	3.2	1.7	3.5	4.5	13.0
	LP/propane <sup>3</sup>	.039	.037	4.9	10.0	4.9	10.0	4.9	10.0	11.0	13.0
110	Natural	.063	.055	1.7	3.5	1.5	3.2	1.7	3.5	4.5	13.0
	LP/propane <sup>3</sup>	.039	.037	4.9	10.0	4.9	10.0	4.9	10.0	11.0	13.0

<sup>1</sup> This is the only permissible derate for these units.

<sup>2</sup> Natural gas high altitude orifice kit required.

<sup>3</sup> A natural to L.P./propane gas changeover kit is necessary to convert this unit. Refer to the changeover kit installation instruction for the conversion procedure.

**NOTE:** Units may be installed at altitudes up to 4500 ft. above sea level without modifications.

Table 22

### High Altitude Pressure Switch Kits

Unit Input	High Altitude Pressure Switch Kit		
	0- 4500 ft.	4501 - 7500 ft.	7501 - 10,000 ft.
070	No Change	No Change	73W 35
090	No Change	69W 56	73W 35
110	No Change	69W 56	73W 35

Table 23

### Honeywell Gas Valve Conversion Kits

Unit Input	High Altitude Natural Gas Orifice Kit	Natural Gas to LP/Propane Kit		LP/Propane to Natural Gas Kit
	7501 - 10,000 ft.	0- 7500 ft.	7501 - 10,000 ft.	0- 7500 ft.
070	51W 01	68W 76	73W 65	73W 32
090	51W 01	68W 76	73W 65	73W 32
110	51W 01	68W 76	73W 65	73W 32

Table 24

### White Rodgers Gas Valve Conversion Kits

Unit Input	High Altitude Natural Gas Orifice Kit	Natural Gas to LP/Propane Kit		LP/Propane to Natural Gas Kit
	7501 - 10,000 ft.	0-7500 ft.	7501 - 10,000 ft.	0- 7500 ft.
070	51W 01	77W 08	77W 12	77W 10
090	51W 01	77W 08	77W 12	77W 10
110	51W 01	77W 08	77W 12	77W 10

Table 25

## OTHER UNIT ADJUSTMENTS

### Primary and Secondary Limits

The primary limit is located on the heating compartment vestibule panel. The secondary limits (if equipped) are located in the blower compartment, attached to the back side of the blower. These auto reset limits are factory set and require no adjustment.

### Flame Rollout Switches (Two)

These manually reset switches are located on (or inside of) the burner box. If tripped, check for adequate combustion air before resetting.

### Pressure Switches

The pressure switch assembly (includes two switches) is located in the heating compartment adjacent to the combustion air inducer. These switches check for proper combustion air inducer operation before allowing ignition trial. The switches are factory-set and require no adjustment.

### Temperature Rise

Place the unit into operation with a second-stage heating demand. After supply and return air temperatures have stabilized, check the temperature rise. If necessary, adjust the heating blower speed to maintain the temperature rise within the range shown on the unit nameplate. Increase the blower speed to decrease the temperature rise. Decrease the blower speed to increase the temperature rise. Failure to properly adjust the temperature rise may cause erratic limit operation.

### Thermostat Heat Anticipation

Set the heat anticipator setting (if adjustable) according to the amp draw listed on the wiring diagram that is attached to the unit.

### Heating Sequence of Operation

#### **Electronic Ignition**

The two-stage, variable speed integrated control used in these units has an added feature of an internal control. The feature serves as an automatic reset device for ignition control lockout caused by ignition failure. After one hour of continuous thermostat demand for heat, the control will break and remake thermostat demand to the furnace and automatically reset the control to begin the ignition sequence.

**NOTE:** *The ignition control thermostat selection DIP switch is factory set in the "TWO STAGE" position.*

### Applications Using a Two-Stage Thermostat A-Heating Sequence - Control Thermostat Selection DIP switch in "Two Stage" Position (Factory Setting)

1. On a call for heat, thermostat first stage contacts close sending a signal to the integrated control. The integrated control runs a self diagnostic program and checks high temperature limit switches for normally closed contacts and pressure switches for normally open contacts. The combustion air inducer is energized at ignition speed, Which is approximately the same as the inducer speed at 70 percent firing rate.
2. Once the control receives a signal that the low fire pressure switch has closed, the combustion air inducer begins a 15 second prepurge in the ignition speed.
3. After the prepurge is complete, a 20 second initial ignitor warm up period begins. The combustion air inducer continues to operate at the ignition speed.
4. After the 20 second warm up period has ended, the gas valve is energized and ignition occurs. At the same time, the control module sends a signal to begin an indoor blower 30 second ON delay. When the delay ends, the indoor blower motor is energized at a speed that matches the firing rate. After the 10 second ignition stabilization delay expires, the inducer speed is adjusted to the appropriate target rate. The inducer will remain at the 70 percent speed as long as the thermostat has a first stage heating demand.
5. If second stage heat is required, the thermostat second stage heat contacts close and send a signal to the integrated control. The integrated control initiates a 30 second second stage recognition delay.
6. At the end of the recognition delay and on all subsequent calls for heat in the same heating cycle, the integrated control energizes the combustion air inducer at high speed. The control also checks the high fire pressure switch to make sure it is closed. As the inducer speed is increased to high, the indoor blower motor is adjusted to a speed which is appropriate for the target rate.
7. When the demand for high fire (second stage) heat is satisfied, the gas valve is de-energized and the field selected indoor blower off delay begins. The combustion air inducer begins a 20 second post purge period.
8. When the thermostat demand for low-fire (first stage) heat is satisfied, the gas valve is de-energized and the field-selected indoor blower OFF delay begins. The combustion air inducer begins a 5 second port-purge period.
9. When the combustion air post purge period is complete, the inducer, the HUM contacts as well as the 120V ACC terminals are de-energized. The indoor blower is de-energized at the end of the OFF delay.

## Application Using a Single Stage Thermostat

### B - Heating Sequence - Integrated Control Thermostat Selection DIP switch 1 ON in "Single-Stage" Position

**NOTE:** In these applications, two-stage heat will be initiated by the integrated control if heating demand has not been satisfied after the field adjustable period (7 or 12 minutes).

1. On a call for heat, thermostat first stage contacts close sending a signal to the integrated control. The integrated control runs a self diagnostic program and checks high temperature limit switches for normally closed contacts and pressure switches for normally open contacts. The combustion air inducer is energized at low speed.
2. Once the control receives a signal that the low pressure switch has closed, the combustion air inducer begins a 15 second prepurge in low speed.

**NOTE:** If the low fire pressure switch does not close the combustion air inducer will switch to high fire. After a 15 second pre-purge the high fire pressure switch will close and the unit will begin operation on high fire. After 10 to 20 seconds of high fire operation the unit will switch to low fire.

3. After the prepurge is complete, a 20 second initial ignitor warm-up period begins. The combustion air inducer continues to operate at the ignition speed.

4. After the 20-second warm-up period has ended, the gas valve is energized on low fire (first stage) and ignition occurs. At the same time, the control module sends a signal to begin an indoor blower 30-second ON-delay. When the delay ends, the indoor blower motor is energized on the low fire heating speed and the HUM contacts are energized. The integrated control also initiates a second-stage on delay (factory-set at 7 minutes; adjustable to 12 minutes).
5. If the heating demand continues beyond the second-stage on delay, the integrated control energizes the combustion air inducer at high speed. The control also checks the high fire (second stage) pressure switch to make sure it is closed. the high fire (second-stage) gas valve is energized and the indoor blower motor is energized for operation at the high fire heating speed.
6. When the thermostat heating demand is satisfied, the combustion air inducer begins a 5-second low speed post-purge. The field-selected indoor blower off delay begins. The indoor blower operates at the low-fire heating speed.
7. When the combustion air post-purge period is complete, the inducer, the HUM contacts as well as the 120V ACC terminals are de-energized. The indoor blower is de-energized at the end of the off delay.

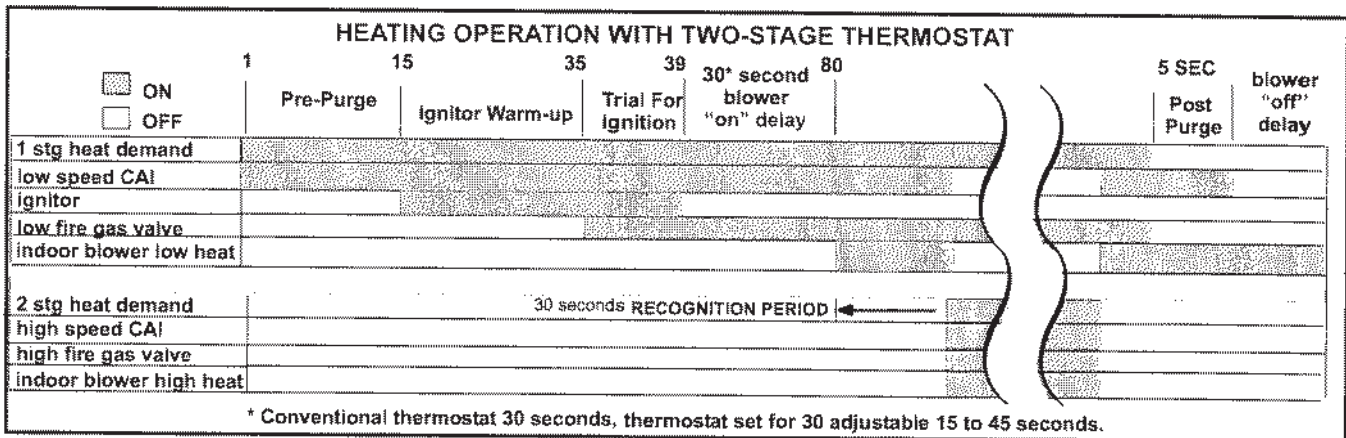

Figure 29

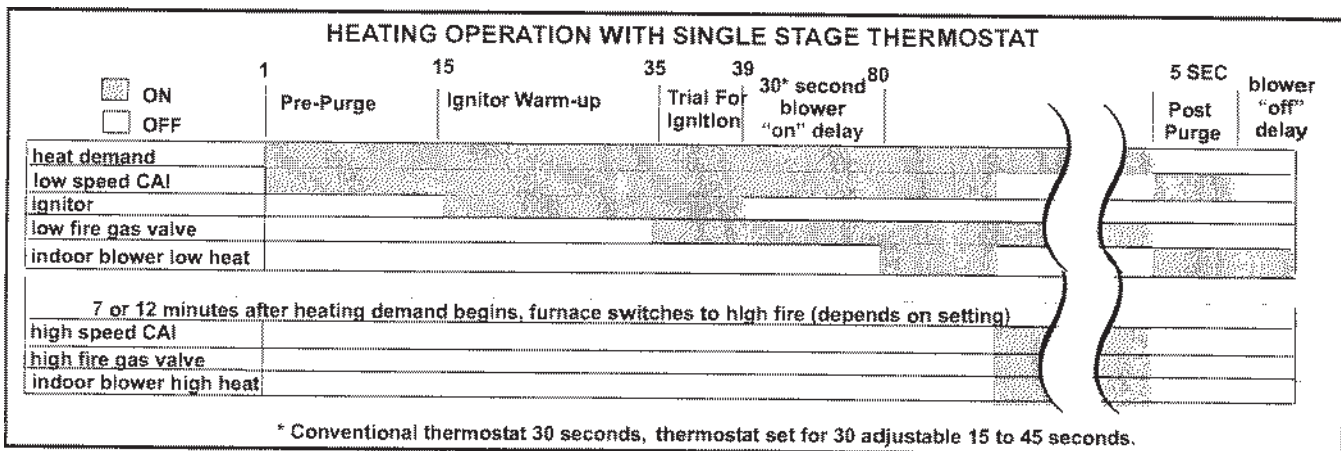

Figure 30

## SERVICE



### **ELECTRICAL SHOCK, FIRE, OR EXPLOSION HAZARD.**

Failure to follow safety warnings exactly could result in dangerous operation, serious injury, death or property damage.

Improper servicing could result in dangerous operation, serious injury, death, or property damage.

Before servicing, disconnect all electrical power to furnace.

When servicing controls, label all wires prior to disconnecting. Take care to reconnect wires correctly. Verify proper operation after servicing.

## **Flue And Chimney**

1. Check flue pipe, chimney and all connections for tightness and to make sure there is no blockage.
2. Check unit for proper draft.

## **Electrical**

1. Check all wiring for loose connections.
2. Check for the correct voltage at the furnace (furnace operating). Correct voltage is 120VAC  $\pm$  10%.
3. Check amp-draw on the blower motor with blower panel in place.

Unit Nameplate \_\_\_\_\_ Actual \_\_\_\_\_

At the beginning of each heating season, a qualified technician should check the system as follows:

## **Blower**

Check the blower wheel for debris and clean if necessary. The blower motors are prelubricated for extended bearing life. No further lubrication is needed.



The blower access panel must be securely in place when the blower and burners are operating. Gas fumes, which could contain carbon monoxide, can be drawn into living space resulting in personal injury or death.

## **Filters**

All filters are installed external to the unit. Filters should be inspected monthly. Clean or replace the filters when necessary to ensure that the furnace operates properly. Replacement filters must be rated for high velocity airflow. Table 3 lists recommended filter sizes.

## Cleaning the Heat Exchanger and Burners

**NOTE:** Use papers or protective covering in front of the furnace during cleaning.

1. Turn off both electrical and gas power supplies to furnace.
2. Remove flue pipe, top cap, flue chase and internal flue pipe assembly from the unit.
3. Label the wires from gas valve, rollout switches, primary limit switch and make up box then disconnect them.
4. Remove the screws that secure the combustion air inducer/pressure switch assembly to the collector box. Carefully remove the combustion air inducer to avoid damaging blower gasket. If gasket is damaged, it must be replaced to prevent leakage.
5. Remove the collector box located behind the combustion air inducer. Be careful with the collector box gasket. If the gasket is damaged, it must be replaced to prevent leakage.
6. Disconnect gas supply piping. Remove the screw securing the burner box cover and remove cover. Remove the four screws securing the burner manifold assembly to the vestibule panel and remove the assembly from the unit.
7. Remove screws securing burner box and remove burner box.
8. Remove screws from both sides, top and bottom of vestibule panel.
9. Remove heat exchanger. It may be necessary to spread cabinet side to allow more room. If so, remove five screws from the left side or right side of cabinet. See Figure 33.
10. Back wash using steam. Begin from the burner opening on each clam. Steam must not exceed 275°F.

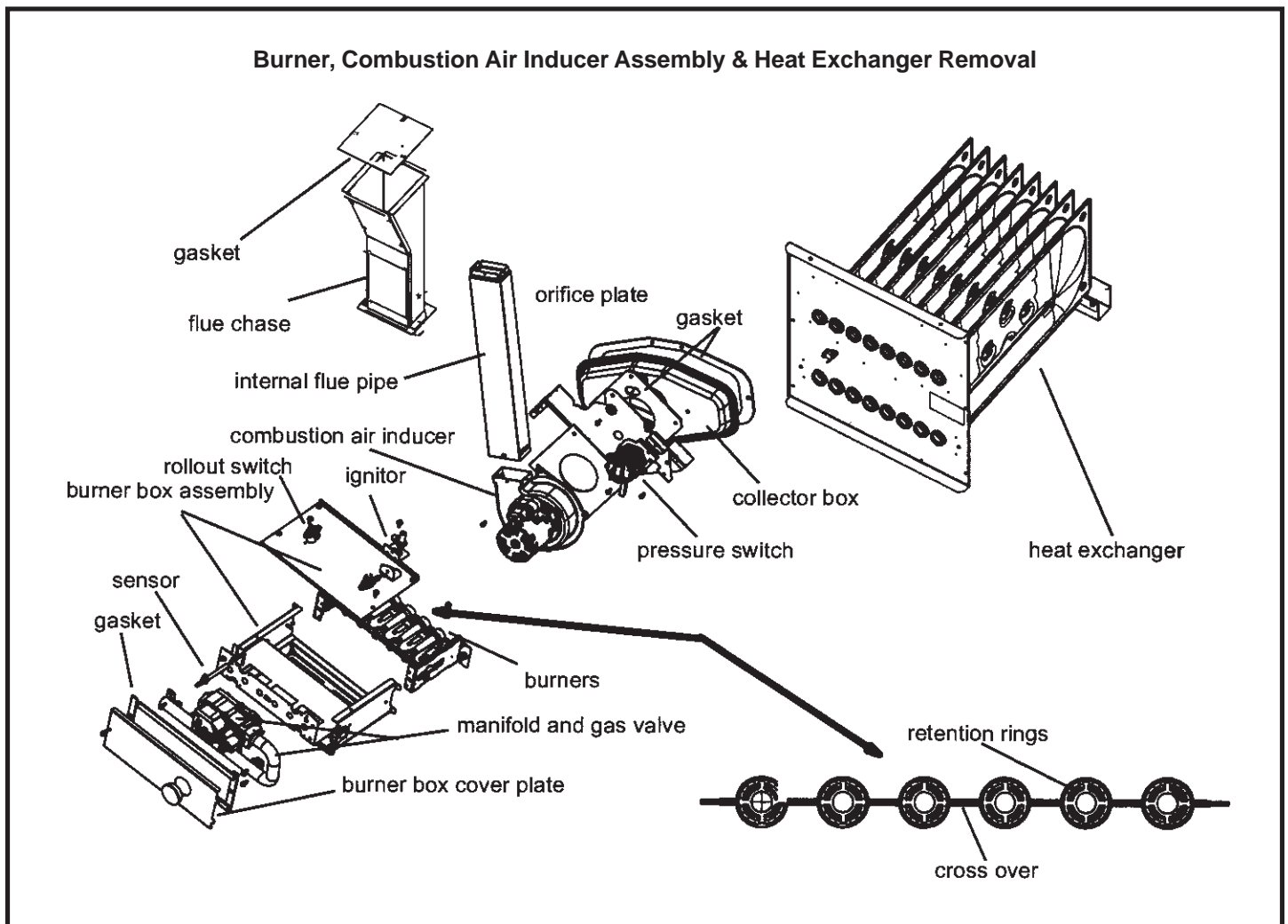

Figure 31

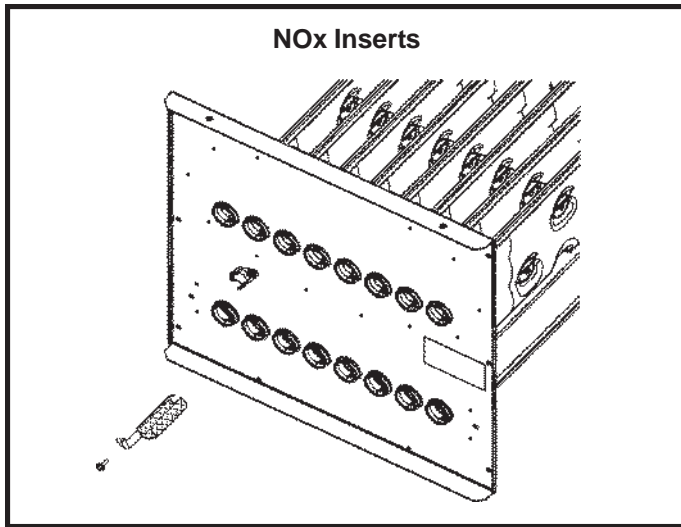

Figure 32

11. To clean burners, run a vacuum cleaner with a soft brush attachment over the face of burners. Visually inspect inside the burners and crossovers for any blockage caused by foreign matter. Remove any blockage. Figure 31 shows burner detail.
12. To clean the combustion air inducer visually inspect and using a wire brush clean where necessary. Use compressed air to clean off debris and any rust.
13. Reinstall heat exchanger in vestibule. (Replace the five screws in the cabinet from step 9 if removed).
14. Reinstall collector box, combustion air assembly, internal flue pipe and flue chase. Seal with high temperature RTV. Reinstall all screws to the collector box and combustion air inducer. Failure to replace all screws may cause leaks. Inspect gaskets for any damage and replace if necessary.
15. Reinstall burner box, manifold assembly and burner box cover.
16. Reconnect all wires.
17. Reconnect top cap and vent pipe to combustion air inducer outlet.
18. Reconnect gas supply piping.
19. Turn on power and gas supply to unit.
20. Set thermostat and check for proper operation.
21. Check all piping connections, factory and field, for gas leaks. Use a leak detecting solution or other preferred means.

**CAUTION**

Some soaps used for leak detection are corrosive to certain metals. Carefully rinse piping thoroughly after leak test has been completed. Do not use matches, candles, flame or other sources of ignition to check for gas leaks.

22. If a leak is detected, shut gas and electricity off and repair leak.
23. Repeat steps 21 and 23 until no leaks are detected.
24. Replace access panel.

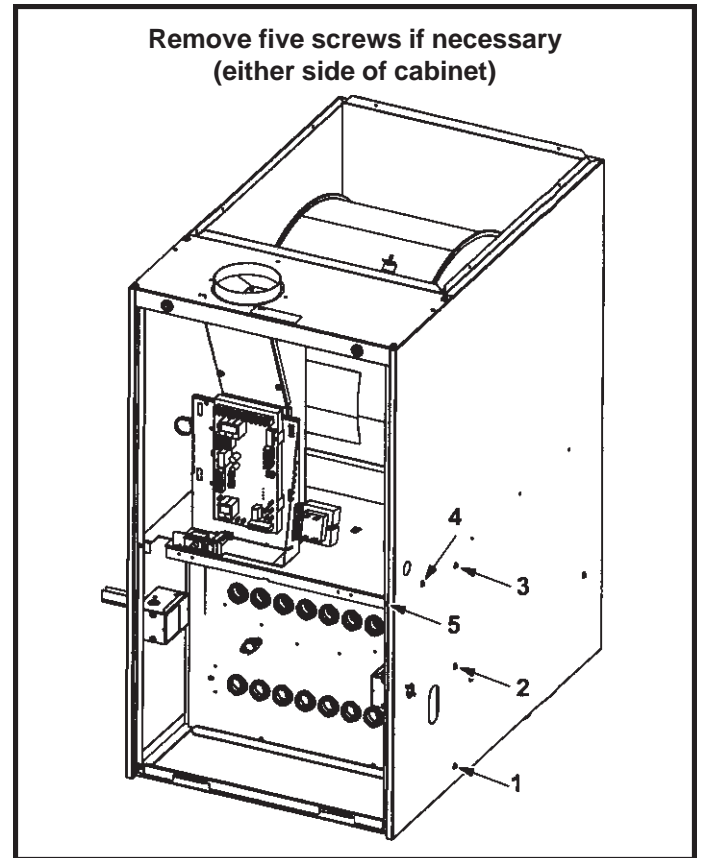

Figure 33

## Planned Service

*The following items should be checked during an annual inspection. Power to the unit must be shut OFF for the service technician's safety.*

**Fresh air grilles and louvers** (on the unit and in the room where the furnace is installed) - Must be open and unobstructed to provide combustion air.

**Burners** - Must be inspected for rust, dirt, or signs of water.

**Vent pipe** - Must be inspected for signs of water, damaged or sagging pipe, or disconnected joints.

**Unit appearance** - Must be inspected for rust, dirt, signs of water, burnt or damaged wires, or components.

**Blower access panel** - Must be properly in place and provide a seal between the return air and the room where the furnace is installed.

**Return air duct** - Must be properly attached and provide an air seal to the unit.

**Operating performance** - Unit must be observed during operation to monitor proper performance of the unit and the vent system.

**Combustion gases** - Flue products must be analyzed and compared to the unit specifications.

Problems detected during the inspection may make it necessary to temporarily shut down the furnace until the items can be repaired or replaced.

**Instruct the homeowners to pay attention to their furnace.** Situations can arise between annual furnace inspections that may result in unsafe operation. For instance, items innocently stored next to the furnace may obstruct the combustion air supply. This could cause incomplete combustion and the production of carbon monoxide gas.

## Repair Parts List

*The following repair parts are available through independent dealers. When ordering parts, include the complete furnace model number listed on the CSA International nameplate. All service must be performed by a licensed professional installer (or equivalent), service agency, or gas supplier.*

### Cabinet Parts

- Heating compartment access panel
- Blower access panel
- Top cap

### Control Panel Parts

- Transformer
- Two-stage, variable speed integrated control
- Door interlock switch

### Blower Parts

- Blower wheel
- Blower housing
- Motor
- Motor electronics
- Power choke (1 hp only)
- Motor mounting frame
- Motor capacitor
- Blower housing cutoff plate

### Heating Parts

- Flame Sensor
- Heat exchanger assembly
- Gas manifold
- Two-speed combustion air inducer
- Two-stage gas valve
- Main burner cluster
- Main burner orifices
- Pressure switch
- Ignitor
- Primary limit control
- Flame rollout switch
- Secondary limit



## Integrated Control Diagnostic Modes

Display	Action (when button released)
No change (idle)*	Remain in idle mode
Solid "E"	Enter diagnostic recall mode
Solid "D"	Discharge Air Installed
Solid "F"	Enter flame signal mode
Solid "P" (variable speed only)	Program unit capacity/size (Unit Code)**

\* No change implies the display will continue to show whatever is currently being displayed for normal operation (blinking decimal, active error code, heat state, etc .. )

\*\* After the "P" is selected (by releasing the push button) the integrated control will start flashing the "P" on display for 90 seconds. If push button is pressed again and held during that time, the control will start to display characters corresponding to different variable speed furnace models for 3 seconds each. While the wanted character-model is displayed push button has to be released. Selected option will flash display for 10 seconds and during that time push button has to be pressed and held for 5 seconds. Once control accepts new setting it will store data in non-volatile memory and reset itself. If 10 seconds expires or push button is held less than 5 seconds, control will exit program mode and go in idle without programming the unit size.

## Integrated Control Diagnostic Codes

Press the diagnostic push button and hold it to cycle through a menu of options. Every five seconds a new menu item will be displayed. Release the button when the desired mode is displayed.

When a solid "P" is displayed, the furnace capacity / size is programmed.

When the solid "E" is displayed, the control enters the Diagnostic Recall (Alarm History). Diagnostic Recall mode menu options: No change (displaying error history) remains in Diagnostic Recall mode; solid "E" exits Diagnostic Recall mode; and solid "c" clears the error history. Must press button while flashing "c" is displayed to clear error codes.

When the solid "F" is displayed, the control enters the Flame Signal Mode. The Flame Signal Mode is exited: with power cycle/reset, by pressing and holding the push button until 3 horizontal line are displayed "≡", after 10 minutes of entering flame signal mode.

Code	Diagnostic Codes / Status of Equipment	Action Required to Clear and Recover
	Idle mode (Decimal blinks at 1 Hertz -- 0.5 second ON, 0.5 second OFF).	
A	Cubic feet per minute (cfm) setting for indoor blower (1 second ON, 0.5 second OFF) / cfm setting for current mode displayed.	
C	Cooling stage (1 second ON, 0.5 second OFF) / 1 or 2 displayed / Pause / cfm setting displayed / Pause / Repeat codes).	
d	Dehumidification mode (1 second ON) / 1 second OFF) / cfm setting displayed / Pause / Repeat Codes).	
h	Heat pump stage (1 second ON, 0.5 second OFF) / % of input rate displayed / Pause / cfm, setting / Pause / Repeat codes.	
H	Gas Heat Stage (1 second ON, 0.5 second OFF) / 1 or 2 displayed / Pause / cfm, setting displayed / Pause / Repeat codes. Blinking during ignition.	
dF	Defrost mode.	
U	Discharge Air Temperature	

## Integrated Control Diagnostic Codes

Code	Diagnostic Codes/Status of Equipment	Action Required to Clear and Recover
E 105	Device communication problem - No other devices on RS BUS. (Communicating systems <b>only</b> ).	Equipment is unable to communicate. Indicates numerous message errors. In most cases errors are related to electrical noise. Make sure high voltage power is separated from RSBus. Check for mis-wired and/or loose connections between the stat., indoor unit and outdoor unit. Check for a high voltage source of noise close to the system. Fault clears after communication is restored.
E 110	Low line voltage	Line Voltage Low (Voltage lower than nameplate rating). Check power line voltage and correct. Alarm clears 5 seconds after fault recovered.
E 111	Line voltage polarity reversed	Reverse line power voltage wiring. System resumes normal operation 5 seconds after fault recovered.
E 112	Ground not detected	System shuts down. Provide proper earth ground. System resumes normal operation 5 seconds after fault recovered.
E 113	High line voltage	Line Voltage High (Voltage higher than nameplate rating). Provide power voltage within proper range. System resumes normal operation 5 seconds after fault recovered.
E 114	Line voltage frequency out-of-range.	No 60 Hertz Power. Check voltage and line power frequency. Correct voltage and frequency problems. System resumes normal operation 5 seconds after fault recovered.
E 115	Low 24V	24-Volt Power Low (Range is 18 to 30 volts). Check and correct voltage. Check for additional power-robbing equipment connected to system. May require installation of larger VA transformer to be installed in furnace / air handler. Clears after fault recovered.
E 116	High 24V.	24 Volt Power High (Range is 18 to 30 Volts). Check and correct voltage. Check for proper line voltage (120V 240V etc) to equipment. Clears when control senses proper voltage.
E 117	Poor ground detected (Warning only)	Provide proper grounding for unit. Check for proper earth ground to the system. Warning only will clear 30 seconds after fault recovered.
E 120	Unresponsive device (Communicating systems <b>only</b> ).	Usually caused by delay in outdoor unit responding to indoor unit polling. Recycle power. Check all wiring connections. Cleared after unresponsive device responds to any inquiry.
E 124	Active communicating thermostat signal missing for more than 3 minutes (Communicating systems <b>only</b> ).	Equipment lost communication with the thermostat. Check four wiring connections: ohm wires and cycle power at the thermostat. Alert stops all services and waits for heartbeat message from thermostat (sub-net controller). Cleared after valid thermostat (sub-net controller) message is received.
E 125	Control failed self-check, internal error, failed hardware. Will restart if error recovers. Integrated control not communicating. Covers hardware errors (flame sense circuit faults, pin shorts, etc.)	Hardware problem on the control. Cycle power on control. Replace if problem prevents service and is persistent. Cleared 300 seconds after fault recovered.
E 126	Control internal communication problem	Hardware problem on the control. Cycle power on control. Replace if problem prevents service and is persistent. Cleared 300 seconds after fault recovered.

**Integrated Control Diagnostic Codes (continued)**

E 131	Corrupted control parameters (Verify configuration of system) (Communicating systems <b>only</b> ).	Reconfigure the system. Replace control if heating or cooling is not available. Only applicable in the communicating mode, not in startup. Exit from Commissioning and Execute 'Set Factory Default mode'. Control will still operate on default parameter settings.
E 180	Outdoor air temperature sensor failure. Only shown if shorted or out-of-range (Communicating systems <b>only</b> ).	Compare outdoor sensor resistance to temperature/resistance charts in unit installation instructions. Replace sensor pack if necessary. At beginning of (any) configuration, furnace or air handler control will sense outdoor air and discharge air temperature sensors; if detected (reading in range), appropriate feature will be set as 'installed' and that could be seen in 'About' screen. In normal operation after control recognizes sensors, alarm will be sent if valid temperature reading is lost. To get rid of setting and alarm, redo configuration and make sure that temperature sensor is marked as 'not installed' in Indoor Unit About screen. When Indoor unit control is replaced, thermostat will tell new control if temperature sensor is in system or not. Clears 30 seconds after fault recovered.
E 200	Hard lockout - Rollout circuit open or previously open	Correct cause of rollout trip, or replace flame rollout switch. Test furnace operation. Cleared after fault recovered.
E 201	Indoor blower communication failure - Unable to communicate with blower motor	Indoor blower communication failure (including power outage). Lost communication with indoor blower motor. Possible causes: motor not powered, loose wiring. Problem may be on control or motor side. Cleared after fault recovered.
E 202	Indoor blower motor mis-match - Indoor motor horsepower does not match unit capacity	Incorrect appliance capacity code selected. Check for proper configuring under 'Unit Size Codes for Furnace/Air Handler' on configuration guide or in installation instructions. Cleared after the correct match is detected following a reset. (Remove thermostat from system while applying power and reprogramming.)
E 203	Appliance capacity/size is NOT programmed - invalid unit codes refer to configuration flow chart.	No appliance capacity code selected. Check for proper configuring under 'Unit Size Codes for Furnace' on configuration guide or in installation instructions. Critical Alert. Cleared after valid unit code is read following a reset. (Remove thermostat from system while applying power and reprogramming.)
E 204	Gas valve mis-wired	Check gas valve operation and wiring. Clears when repaired.
E 205	Gas valve control relay contact shorted	Check wiring on control and gas valve. If wiring is correct, replace control.
E 206	Gas valve second-stage relay failure	Furnace will operate on 1st stage for remainder of the heating demand. Will clear after fault recovered. If unable to operate 2nd stage, replace control.
E 207	Hot surface ignitor sensed open - Refer to troubleshooting	Measure resistance of hot surface ignitor. Replace if open or not within specified range found in 10M. Resumes normal operation after fault is cleared.

**Integrated Control Diagnostic Codes (continued)**

Code	Diagnostic Codes/Status of Equipment	Action Required to Clear and Recover
E 223	Low pressure switch failed open	Check pressure (inches w.c.) of low pressure switch closing on heat call. Measure operating pressure (inches w.c.) Inspect vent and combustion air inducer for correct operation and restriction. Resumes normal operation after fault is cleared.
E 224	Low pressure switch failed closed - Refer to troubleshooting	Check operation of low pressure switch to see if it is stuck closed on heat call longer than 150 seconds. Measure operating pressure (inches w.c.) Inspect vent and combustion air inducer for correct operation and restriction. Resumes normal operation after fault is cleared.
E 225	High pressure switch failed open - Refer to troubleshooting	Check pressure (inches w.c.) of high pressure switch closing on heat call. Measure operating pressure (inches w.c.) Inspect vent and combustion air inducer for correct operation and restriction. Resumes normal operation after fault is cleared.
E 226	High pressure switch failed closed - Refer to troubleshooting	Check operation of high pressure switch closing on heat call. Measure operating pressure (inches w.c.) Inspect vent and combustion air inducer for correct operation and restriction. Resumes normal operation after fault is cleared.
E 227	Low pressure switch open during trial for ignition or run mode. Refer to troubleshooting	Check pressure (inches w.c.) of low pressure switch closing on heat call. Measure operating pressure (inches w.c.) Inspect vent and combustion air inducer for correct operation and restriction. Resumes normal operation after fault is cleared.
E 228	Combustion air inducer calibration failure	Unable to perform pressure switch calibration. Check vent system and pressure switch wiring connections. Resumes normal operation after fault is cleared.
E 229	Ignition on high fire	IFC switched to high fire ignition because low fire pressure switch did not close in allowed time. No action is needed.
E 240	Low flame current! - Run mode - Refer to troubleshooting.	Check micro-amperes of flame sensor using control diagnostics or field-installed mode. Clean or replace sensor. Measure voltage of neutral to ground to ensure good unit ground. Alert clears after current heat call has been completed.
E 241	Flame sensed out of sequence - Flame still present.	Shut off gas. Check for gas valve leak. Replace if necessary. Alert clears when fault is recovered.
E 250	Limit switch circuit open - Refer to troubleshooting.	Check for proper firing rate on furnace. Ensure there is no blockage in heater. Check for proper air flow. If limit not closed within 3 minutes unit will go into 1-hour soft lockout. Resumes normal operation after fault is cleared.
E 252	Discharge air temperature too high (gas heat only).	Check temperature rise, air flow and input rate. Cleared when heat call is finished.
E 270	Soft lockout - Exceeded maximum number of retries. No flame current sensed.	Check for proper gas flow. Ensure that ignitor is lighting burner. Check flame sensor current. Clears when heat call finishes successfully.
E 271	Soft lockout - Exceeded maximum number of retries. Last retry failed due to the pressure switch opening	Check pressure (inches w.c.) of low pressure switch closing on heat call. Measure operating pressure (inches w.c.) Inspect vent and combustion air inducer for correct operation and restriction. Clears when heat call finishes successfully.

**Integrated Control Diagnostic Codes (continued)**

E 272	Soft lockout - Exceeded maximum number of recycles. Last recycle due to the pressure switch opening.	Check operation of low pressure switch to see if it is stuck closed on heat call. Check pressure (inches w.c.) of high pressure switch closing on heat call. Measure operating pressure (inches w.c.). Inspect vent and combustion air inducer for correct operation and restriction. Clears when heat call finishes successfully.
E 273	Soft lockout - Exceeded maximum number of recycles. Last recycle due to flame failure.	Check micro-amperes of flame sensor using control diagnostics or field-installed mode. Clean or replace sensor. Measure voltage of neutral to ground to ensure good unit ground. Clears when heat call finishes successfully.
E 274	Soft lockout - Exceeded maximum number of recycles. Last recycle failed due to the limit circuit opening or limit remained open longer than 3 minutes.	Shut down system. 1-hour soft lockout. Check firing rate and air flow. Check for blockage. Clears when heat call finishes successfully.
E 275	Soft lockout - Flame sensed out of sequence. Flame signal is gone.	Shut off gas. Check for gas valve leak. 1-hour soft lockout. Clears when flame has been proven stable.
E 276	Watchguard calibration failure.	Unable to perform pressure switch calibration. Check vent system and pressure switch wiring connections. 1-hour soft lockout. Clears when calibration has finished successfully.
E 290	Ignitor circuit fault - Failed ignitor or triggering circuitry.	Measure resistance of hot surface ignitor. Replace if open or not within specifications. 1-hour soft lockout. Clears when flame has been proven stable.
E 291	Heat air flow restricted below the minimum.	Check for dirty filter and air flow restriction. Check blower performance. 1-hour soft lockout. Cleared when heat call finishes successfully.
E 292	Indoor blower motor unable to start due to obstructed wheel/seized bearings.	Indoor blower motor unable to start (seized bearing, stuck wheel, etc.). Replace motor or wheel if assembly does not operate or meet performance standards. 1-hour soft lockout. Clears after circulator successfully starts.
E 294	Combustion air inducer over current.	Check combustion blower bearings, wiring and amps. Replace if does not operate or does not meet performance standards. Clears after inducer current is sensed to be in-range after the ignition following the soft lockout or reset.
E 295	Indoor blower motor temperature is too high.	Indoor blower motor over temperature (motor tripped on internal protector). Check motor bearings and amps. Replace if necessary. Cleared after blower demand is satisfied.
E 310	Discharge error temperature sensor failure. Only shown if shorted or out of range.	Compare discharge sensor resistance to temperature resistance charts in installation instructions. Replace sensor if necessary. Cleared in Communicating mode: 30 seconds after fault recovered. In Non-Communicating mode: Cleared after the current heat call is completed.
E 311	Heat rate reduced to match indoor blower air flow.	Warning Only. Furnace blower in cutback mode due to restricted airflow. Reduce firing rate every 60 seconds to match available CFM. Check filter and duct system. To clear, replace filter if needed or repair/add duct. 2-stage controls will reduce firing rate to 1 <sup>st</sup> stage. Clears when heat call finishes successfully.

## Integrated Control Diagnostic Codes (continued)

Code	Diagnostic Codes/Status of Equipment	Action Required to Clear and Recover
E 312	Restricted air flow in cooling or continuous fan mode is lower than <b>cfm</b> setting	Warning Only - Restricted airflow - Indoor blower is running at a reduced CFM (Cutback Mode) - The variable speed motor has pre-set speed and torque limiters to protect the motor from damage caused by operating outside of design parameters (0 to 0.8 W.C. total external static pressure). Check filter and duct system. To clear, replace filter if needed or repair/add duct. Cleared after the current service demand is satisfied.
E 313	Indoor or outdoor unit capacity mismatch - Communication only	Incorrect indoor/outdoor capacity code selected. Check for proper configuring in installation instructions. Alarm is just a warning. The system will operate, but might not meet efficiency and capacity parameters. Alarm will clear when commissioning is exited. Cleared after commissioning is complete.
E 331	Global network connection - Communication link problem	For Future Use
E 334	Relay - 1 stuck on integrated control	Replace integrated control
E 347	No 24 Volt output on Y1 of "integrated control" with non-communicating outdoor unit.	Operation stopped - Y1 relay - Stage 1 failed (Pilot relay contacts did not close or the relay coil did not energize - no input back to IFC chip). Critical Alert. Cleared after reset and Y1 input sensed.
E 348	No 24 Volt output on Y2 of "integrated control" with non-communicating outdoor unit.	Y2 relay - Stage 2 failed (Pilot relay contacts did not close or the relay coil did not energize - no input back to IFC chip). Critical Alert. Cleared after reset and Y1 input sensed.
E 349	No 24 Volts between R & 0 on "integrated control" with non-communicating outdoor unit (Dual fuel module required for heat pump application)	Configuration link R to 0 needs to be restored. Replace link or hard-wire. Applicable in non-communicating mode. Critical Alert.
E 370	Interlock switch sensed open for 2 minutes	Control sees the loss of 24VAC for 2 minutes. Terminate all services and warn for interlock switch to close. The alarm will clear when 24VAC is continuously sensed on DS terminal for a minimum of 10 seconds or on a power reset.

# Program Unit Capacity / Size Mode

**Power-Up** - Number displayed represents by integrated control unit size code (furnace model and capacity). If three horizontal bars are displayed followed by continuous E203, furnace control does not recognize **unit size code**. Configure per the following:



Furnace control in **IDLE** mode  
No heating, cooling or indoor fan operation

Yes

No

To enter **Program Unit Capacity/Size**: push and hold button next to 7-segment LED display until solid "P" symbol appears. Release button.

**IMPORTANT:** Field replacement controls may need to be manually configured to validate furnace unit size code.

Turn room thermostat to OFF

Solid **P** starts blinking on 7-Segment LED

UNIT SIZE CODE	FURNACE MODEL	UNIT SIZE CODE	FURNACE MODEL
A	A80US2V070A12*	H	A80DS2V070A12*
b	A80US2V090B12*	J	A80DS2V090B16*
C	A80US2V090B16*	O	A80DS2V110C20*
d	A80US2V090C20*		
E	A80US2V110C20*		
F	A80US2V135D20*		

Push and hold button. Integrated control will display unit size code number for each furnace model for three seconds.

When the correct unit size code is displayed, release button. Selected code will flash for 10-second period. During that period, press and hold push button for 5 seconds. Integrated control will store code in memory and will automatically exit **Program Unit Capacity/Size Mode** and reset. (If second period expires or push button is held less than five seconds, control will automatically exit **Program Capacity/Size Mode** and go into **IDLE** mode without storing unit size code. If this happens, programming function must be repeated).

Verify that the selected unit size code is correct and stored in non-volatile memory by cycling the 24 volt power to the furnace control. (At 24 volt power-up of the furnace control, the 7-segment LED will display a unit size code. If three horizontal bars display, board does not recognize unit size code. Programming function must be repeated)

FINISHED

# Troubleshooting: Heating Sequence of Operation

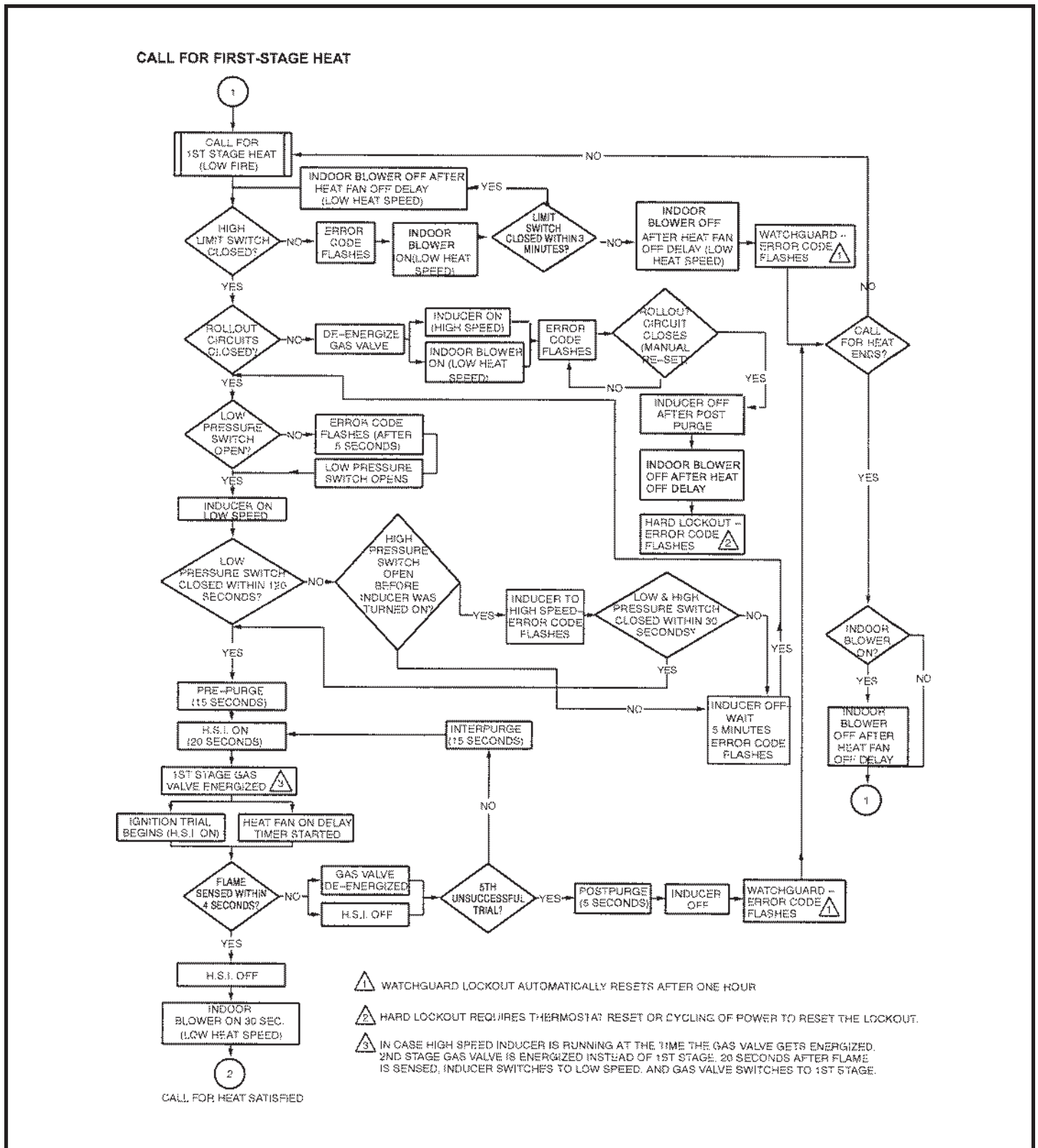



Troubleshooting: Heat Sequence of Operation (continued)

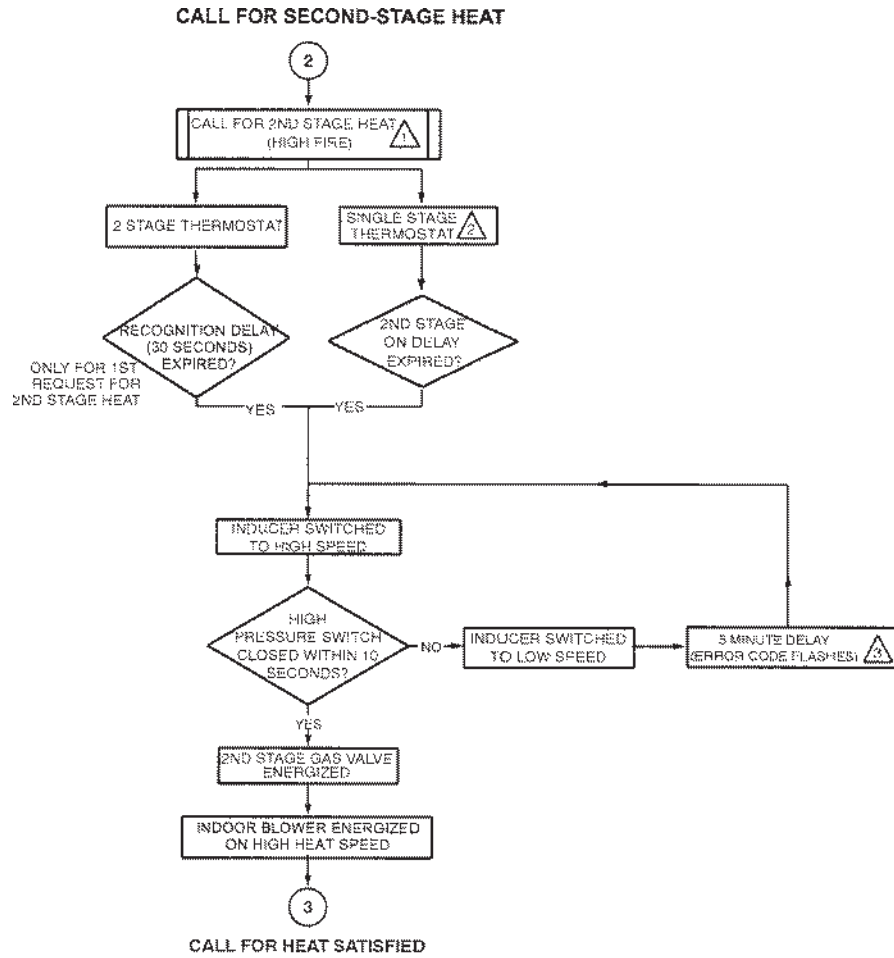

- ⚠️ 1 SYSTEM WILL ALWAYS LIGHT ON LOW FIRE. EVEN IF 2ND STAGE HEAT IS IN PLACE.
- ⚠️ 2 WHEN USED WITH A SINGLE STAGE THERMOSTAT SET SW1 TO THE ON POSITION IN DIP SWITCH S4.
- ⚠️ 3 IF THE HIGH FIRE PRESSURE SWITCH DOES NOT CLOSE WITHIN 5 ATTEMPTS, THE SYSTEM WILL OPERATE AT LOW FIRE FOR THE REMAINDER OF THE CALL FOR HEAT REQUEST.

Troubleshooting: Heat Sequence of Operation (continued)

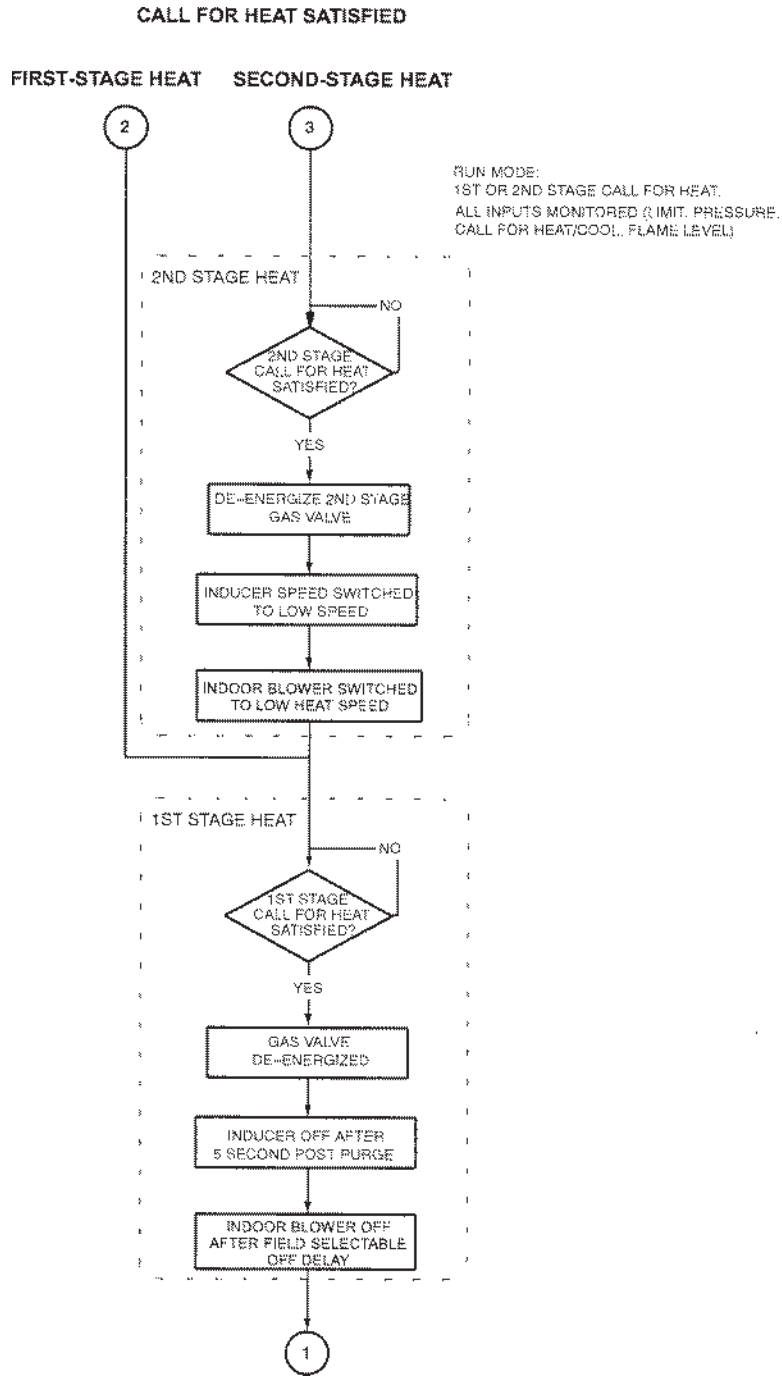

Troubleshooting: Heat Sequence of Operation (continued)

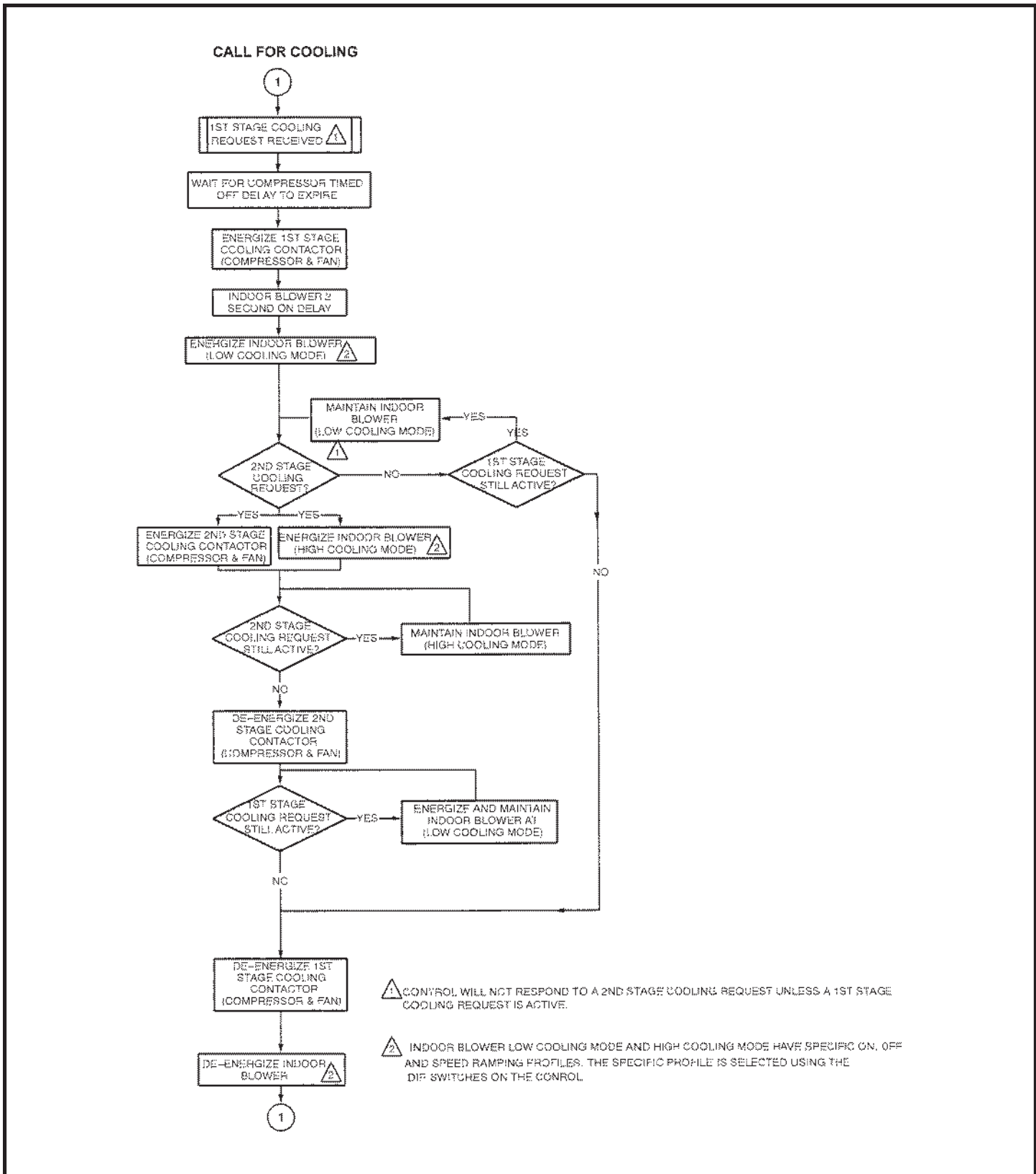

# Troubleshooting: Continuous Fan Sequence of Operation

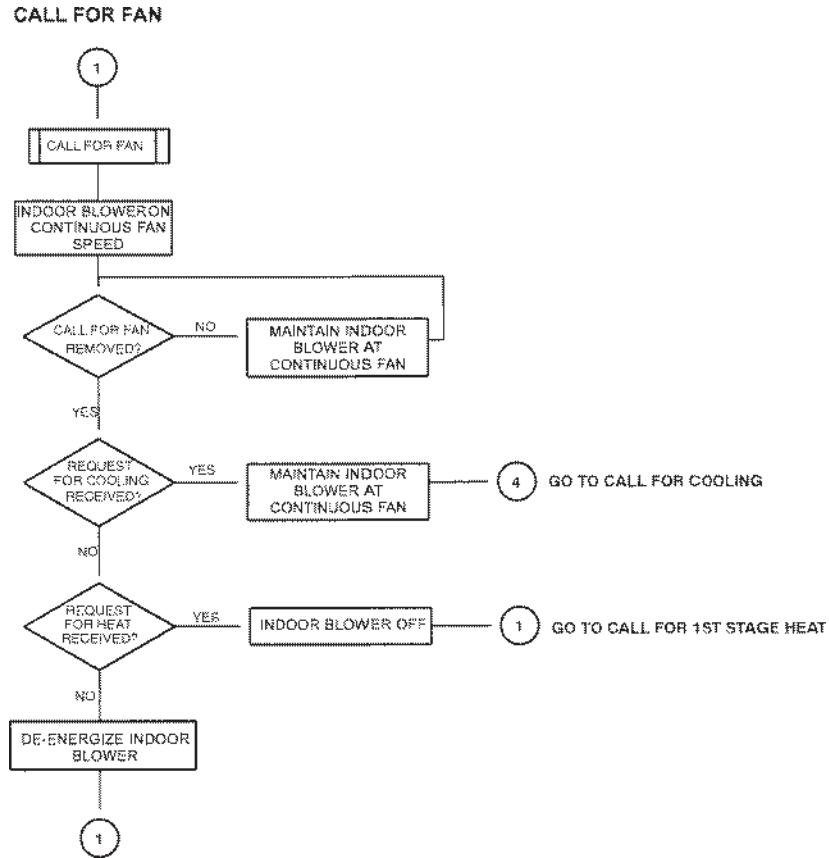

Start-Up & Performance Check List

UNIT SET UP

Furnace:  
Model Number \_\_\_\_\_

Serial Number \_\_\_\_\_

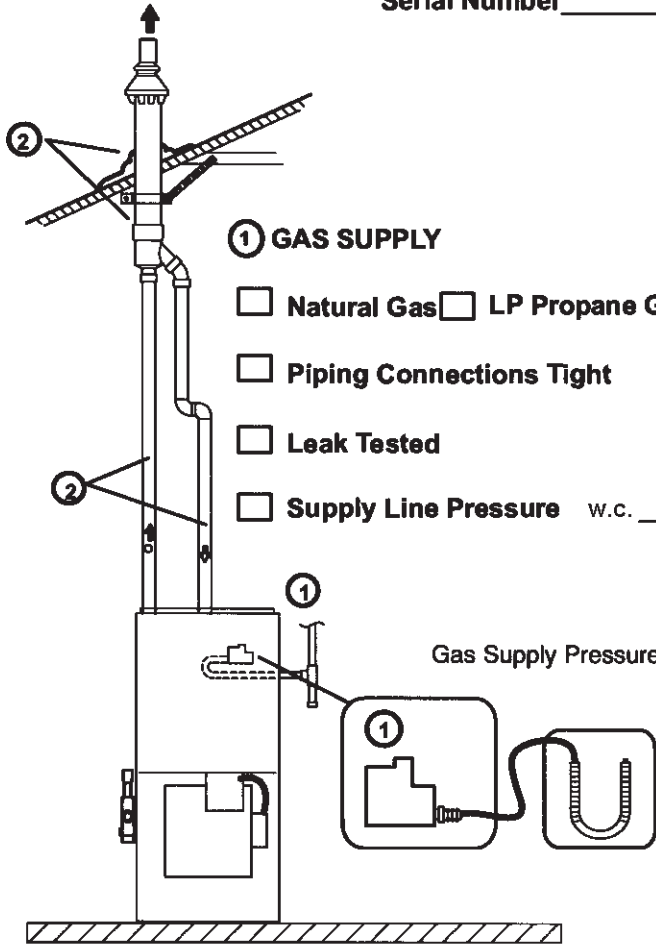

① GAS SUPPLY

- Natural Gas  LP Propane Gas
- Piping Connections Tight
- Leak Tested
- Supply Line Pressure w.c. \_\_\_\_\_

Gas Supply Pressure

Line Voltage

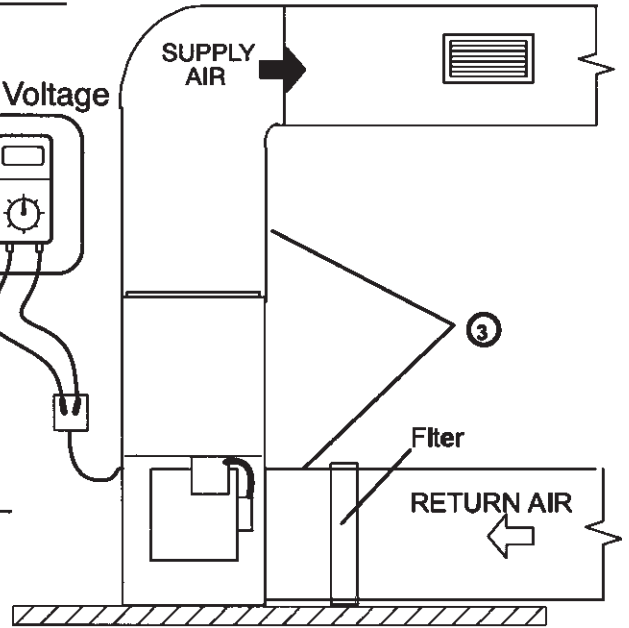
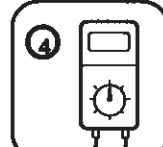

③ DUCT SYSTEM

SUPPLY AIR DUCT

- Sealed
- Insulated (if necessary)

RETURN DUCT

- Sealed
- Filter Installed and Clean
- Grilles Unobstructed

④ VOLTAGE CHECK

Supply Voltage \_\_\_\_\_

- Electrical Connections Tight

② INTAKE / EXHAUST PIPE

- All Joints Primed and Glued
- Terminations Installed Properly
- Horizontal Pipes Sloped (if applicable)
- Condensate Trap Primed / Line Sloped
- Pipes Supported
- Heat Cable Installed and Operable (if applicable)

Start-Up & Performance Check List - continued

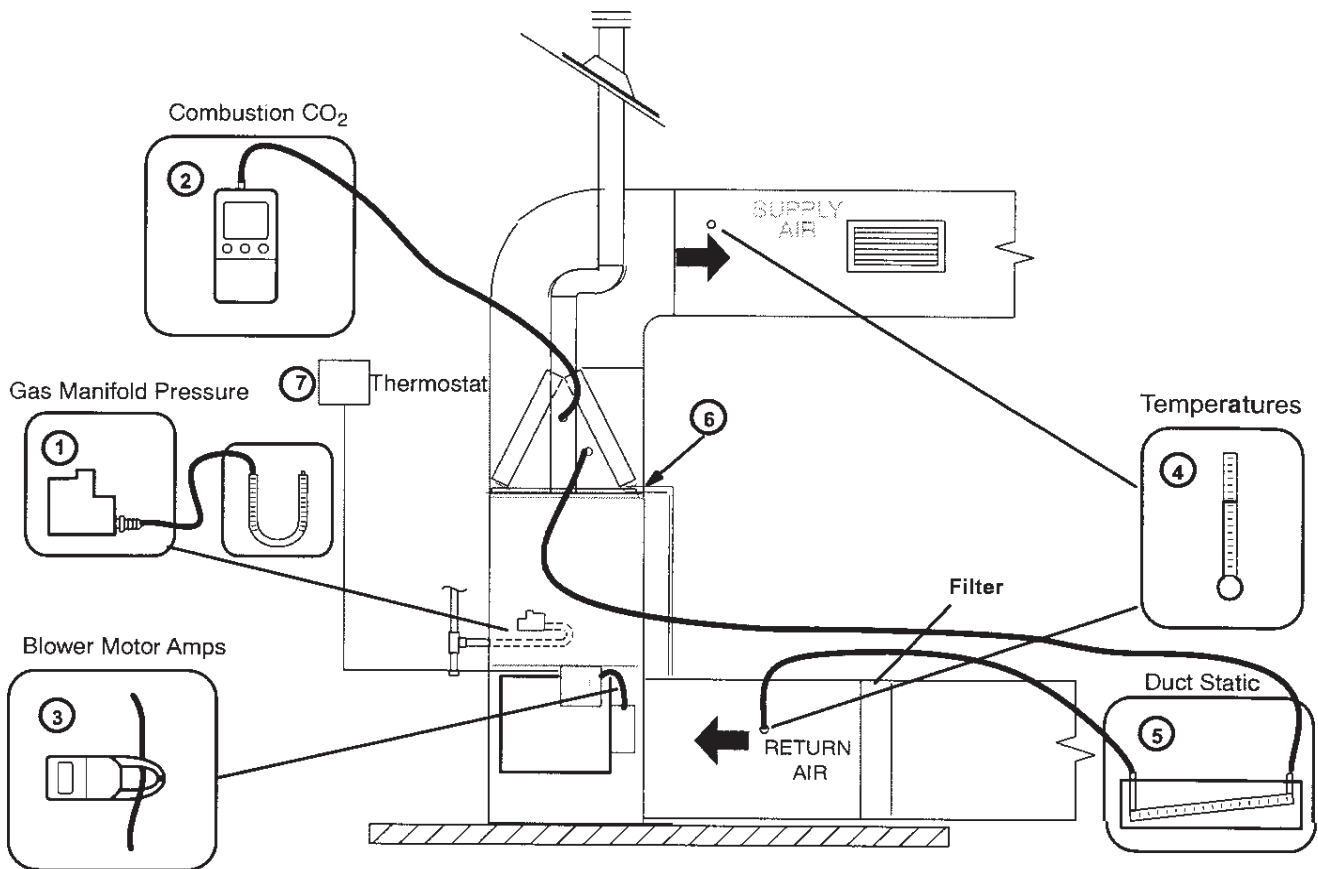

**HEATING MODE**

- ① GAS MANIFOLD PRESSURE "W.C. \_\_\_\_\_
- ② COMBUSTION SAMPLE CO<sub>2</sub>% \_\_\_\_\_ CO PPM \_\_\_\_\_
- ③ INDOOR BLOWER AMPS \_\_\_\_\_
- ④ TEMPERATURE RISE  
 Supply Duct Temperature \_\_\_\_\_  
 Return Duct Temperature - \_\_\_\_\_  
 Temperature Rise = \_\_\_\_\_
- ⑤ TOTAL EXTERNAL STATIC (dry coil)  
 Supply External Static \_\_\_\_\_  
 Return External Static + \_\_\_\_\_  
 Total External Static = \_\_\_\_\_

**COOLING MODE**

- ③ INDOOR BLOWER AMPS \_\_\_\_\_
- ④ TEMPERATURE DROP  
 Return Duct Temperature \_\_\_\_\_  
 Supply Duct Temperature - \_\_\_\_\_  
 Temperature Drop = \_\_\_\_\_
- ⑤ TOTAL EXTERNAL STATIC (dry coil)  
 Supply External Static \_\_\_\_\_  
 Return External Static + \_\_\_\_\_  
 Total External Static = \_\_\_\_\_
- ⑥ DRAIN LINE  
 Leak Free
- ⑦ THERMOSTAT  
 Adjusted and Programmed  
 Operation Explained to Owner

Contractor's: Name \_\_\_\_\_ Telephone \_\_\_\_\_ Checklist Completed \_\_\_\_\_

Job Address \_\_\_\_\_ Technician's Name \_\_\_\_\_

# REQUIREMENTS for COMMONWEALTH of MASSACHUSETTS

## Modifications to NFPA-54, Chapter 10

### Revise NFPA-54 section 10.8.3 to add the following requirements:

For all side wall, horizontally vented, gas-fueled equipment installed in every dwelling, building or structure used in whole or in part for residential purposes, including those owned or operated by the Commonwealth and where the side wall exhaust vent termination is less than seven (7) feet above the finished grade in the area of the venting, including but not limited to decks and porches, the following requirements shall be satisfied:

1. **INSTALLATION OF CARBON MONOXIDE DETECTORS.** At the time of installation of the side wall, horizontally vented, gas-fueled equipment, the installing plumber or gas fitter shall observe that a hard-wired carbon monoxide detector with an alarm and battery backup is installed on the floor level where the gas equipment is to be installed. In addition, the installing plumber or gas fitter shall observe that a battery-operated or hard-wired carbon monoxide detector with an alarm is installed on each additional level of the dwelling, building or structure served by the side wall, horizontally vented, gas-fueled equipment. It shall be the responsibility of the property owner to secure the services of qualified licensed professionals for the installation of hard-wired carbon monoxide detectors.
  - a. In the event that the side wall, horizontally vented, gas-fueled equipment is installed in a crawl space or an attic, the hard-wired carbon monoxide detector with alarm and battery backup may be installed on the next adjacent floor level.
  - b. In the event that the requirements of this subdivision cannot be met at the time of completion of installation, the owner shall have a period of thirty (30) days to comply with the above requirements; provided, however, that during said thirty (30) day period, a battery-operated carbon monoxide detector with an alarm shall be installed.
2. **APPROVED CARBON MONOXIDE DETECTORS.** Each carbon monoxide detector as required in accordance with the above provisions shall comply with NFPA 720 and be ANSI/UL 2034 listed and IAS certified.
3. **SIGNAGE.** A metal or plastic identification plate shall be permanently mounted to the exterior of the building at a minimum height of eight (8) feet above grade directly in line with the exhaust vent terminal for the horizontally vented, gas-fueled heating appliance or equipment. The sign shall read, in print size no less than one-half (1/2) inch in size, "**GAS VENT DIRECTLY BELOW. KEEP CLEAR OF ALL OBSTRUCTIONS.**"

4. **INSPECTION.** The state or local gas inspector of the side wall, horizontally vented, gas-fueled equipment shall not approve the installation unless, upon inspection, the inspector observes carbon monoxide detectors and signage installed in accordance with the provisions of 248 CMR 5.08(2)(a) 1 through 4.

### **EXEMPTIONS: The following equipment is exempt from 24 CMR 5.08(2)(a) 1 through 4:**

1. The equipment listed in Chapter 10 entitled "Equipment Not Required to Be Vented" in the most current edition of NFPA 54 as adopted by the Board; and
2. Product Approved side wall, horizontally vented, gas-fueled equipment installed in a room or structure separate from the dwelling, building or structure used in whole or in part for residential purposes.

### **MANUFACTURER REQUIREMENTS - GAS EQUIPMENT VENTING SYSTEM PROVIDED.**

When the manufacturer of Product Approved side wall, horizontally vented, gas-fueled equipment provides a venting system design or venting system components with the equipment, the instructions provided by the manufacturer for installation of the equipment and the venting system shall include:

1. Detailed instructions for the installation of the venting system design or the venting system components; and
2. A complete parts list for the venting system design or venting system.

### **MANUFACTURER REQUIREMENTS - GAS EQUIPMENT VENTING SYSTEM NOT PROVIDED.**

When the manufacturer of Product Approved sidewall, horizontally vented, gas-fueled equipment does not provide the parts for venting the flue gases, but identifies "special venting systems," the following requirements shall be satisfied by the manufacturer:

1. The referenced "special venting system" instructions shall be included with the appliance or equipment installation instructions; and
2. The "special venting systems" shall be Product Approved by the Board, and the instructions for that system shall include a parts list and detailed installation instructions.

**A copy of all installation instructions for all Product Approved side wall, horizontally vented, gas-fueled equipment, all venting instructions, all parts lists for venting instructions, and/or all venting design instructions shall remain with the appliance or equipment at the completion of the installation.**