

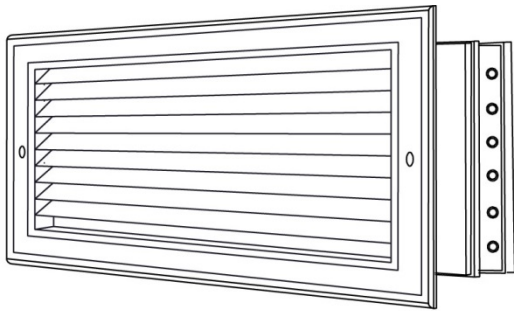

Commercial Submittal Sheet

905 Series

Aluminum Airfoil Blade Grille



Model: 905

Description: Aluminum Airfoil Blade Grille with 45° Fixed Blade (blades parallel to longest dimension)

Standard Features:

- Extruded aluminum surface mount frame with signature line marks
- Fixed airfoil blades at 45° are parallel to longest dimension
- Countersunk mounting holes for flush appearance with color matching Phillips posi-drive screws
- Soft White

Options:

- Recessed screwdriver operated Opposed Blade Damper (905-0)
- Square to round ADC compliant 2" No Labor Collar with roll formed retention bead (905-NLC), available in square sizes only
- Heavy duty construction (905-HD)
- Insect Screen (905-IS)
- Fractional I.D. and O.D. sizes available

Tamper Proof Screws

- "F" Torx Center Pin

Finishes:

Standard Colors

- Soft White
- Driftwood Tan

Designer Colors

- Almond
- Black Velvet
- Bronze
- Camaro Silver
- Coffee Tan
- Navajo White
- Vanilla

Other

- Anodized
- Mill (no paint)

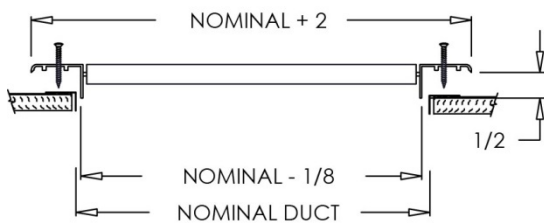

905

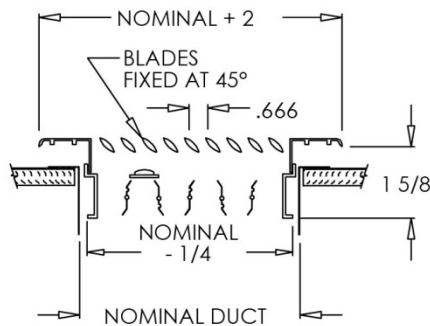

905-O

Additional Information:

Project / Location:
Engineer:
Architect:
Contractor:

Submittal Notes