

INSTALLATION AND MAINTENANCE INSTRUCTIONS

4SCU 16/18LS SERIES

Split System Air Conditioner

These instructions must be read and understood completely before attempting installation.

WARNING

The equipment covered in this manual is to be installed by trained and experienced service and installation technicians. Improper installation, modification, service, or use can cause electrical shock, fire, explosion, or other conditions which may cause personal injury, death, or property damage. Use appropriate safety gear including safety glasses and gloves when installing this equipment.

WARNING

Risk of electrical shock. Disconnect all remote power supplies before installing or servicing any portion of the system. Failure to disconnect power supplies can result in property damage, personal injury, or death.

WARNING

Installation and servicing of air conditioning equipment can be hazardous due to internal refrigerant pressure and live electrical components. Only trained and qualified service personnel should install or service this equipment. Installation and service performed by unqualified persons can result in property damage, personal injury, or death.

WARNING

Sharp metal edges can cause injury. When installing the unit, use care to avoid sharp edges.

TABLE OF CONTENTS

INSTALLATION	2
CONNECTION DIAGRAM.....	4
START-UP.....	14
OPERATION.....	17
ALERT CODE.....	21
MAINTENANCE	26
WARRANTY	31

Manufactured By
Allied Air Enterprises, Inc.
A Lennox International Inc. Company
215 Metropolitan Drive
West Columbia, SC 29170



P506859-01

INSTALLATION

General

Read this entire instruction manual, as well as the instructions supplied in separate equipment, before starting the installation. Observe and follow all warnings, cautions, instructional labels, and tags. Failure to comply with these instructions could result in an unsafe condition and/or premature component failure.

These instructions are intended as a general guide only for use by qualified personnel and do not supersede any national or local codes in any way. The installation must comply with all provincial, state, and local codes as well as the National Electrical Code (U.S.) or Canadian Electrical Code (Canada). Compliance should be determined prior to installation.

4SCU16/18LS condensing units use R410A which is an ozone-friendly HFC refrigerant. The unit must be installed with a matching indoor coil and line set. A filter drier approved for use with R410A is installed in the unit.

IMPORTANT: *This product has been designed and manufactured to meet ENERGY STAR criteria for energy efficiency when matched with appropriate coil components. However, proper refrigerant charge and proper air flow are critical to achieve rated capacity and efficiency. Installation of this product should follow the manufacturer's refrigerant charging and air flow instructions. Failure to confirm proper charge and airflow may reduce energy efficiency and shorten equipment life.*

When servicing or repairing HVAC components, ensure the fasteners are appropriately tightened. Table 1 shows torque values for fasteners.

Fastener	Torque
Stem Caps	8 ft. lbs.
Service Port Caps	8 ft. lbs.
Sheet Metal Screws	16 in. lbs.
#8 Machine Screws	16 in. lbs.
#10 Machine Screws	28 in. lbs.
Compressor Bolts	90 in. lbs.

Table 1

Inspection of Shipment

Upon receipt of equipment, carefully inspect it for possible shipping damage. If damage is found, it should be noted on the carrier's freight bill. Take special care to examine the unit inside the carton if the carton is damaged. Any concealed damage discovered should be reported to the last carrier immediately, preferably in writing, and should include a request for inspection by the carrier's agent. If any damages are discovered and reported to the carrier DO NOT INSTALL THE UNIT, as claim may be denied.

Check the unit rating plate to confirm specifications are as ordered.

Location of Unit

Outdoor units operate under a wide range of weather conditions; therefore, multiple factors must be considered when positioning the unit. The unit must be positioned to give adequate clearances for sufficient airflow and servicing. Refer to Figure 1 for installation clearances.

- Place a sound-absorbing material, such as Isomode under the unit if it will be installed in a location or position that will transmit sound or vibration to the living area or adjacent buildings.

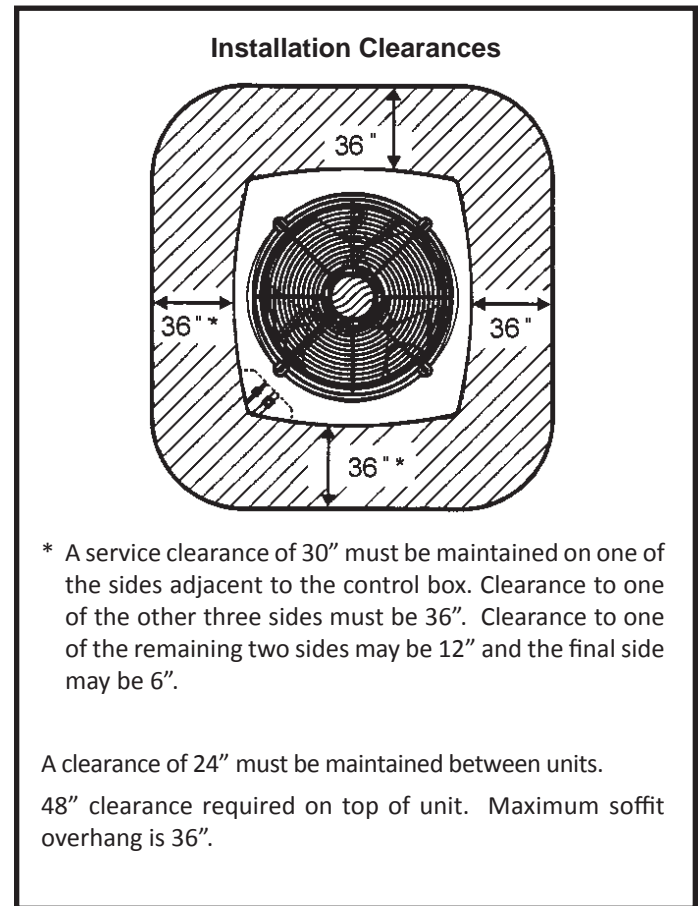

Figure 1

Slab Mounting

When installing a unit at grade level, install on slab high enough above grade so that water from higher ground will not collect around the unit (See Figure 2).

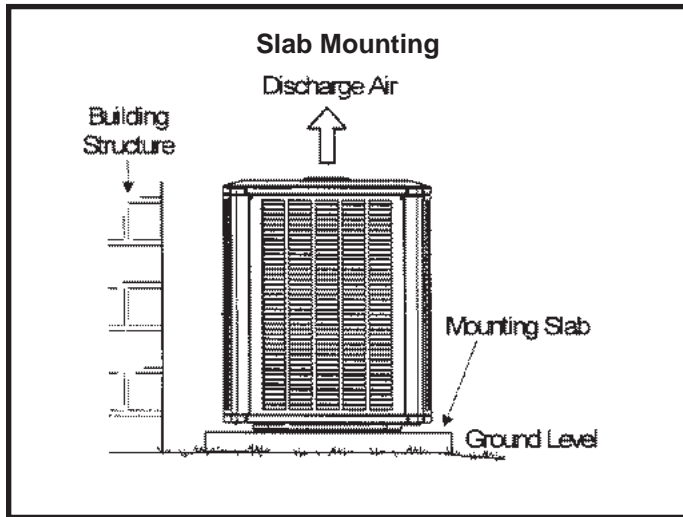

Figure 2

Roof Mounting

Install unit at a minimum of 4" above surface of the roof. Locate the unit above a load bearing wall or area of the roof that can adequately support the unit. Consult local codes for rooftop applications.

Electrical Wiring

All field wiring must be done in accordance with the National Electrical Code (NEC) recommendations, Canadian Electrical Code (CEC) and CSA Standards, or local codes, where applicable.

Refer to the furnace or blower coil installation instructions for additional wiring application diagrams and refer to unit rating plate for minimum circuit ampacity and maximum overcurrent protection size.

⚠ WARNING

Unit must be grounded in accordance with national and local codes. Failure to ground unit properly can result in personal injury or death.

⚠ WARNING

Line voltage is present at all components when unit is not in operation on units with single pole contactors. Disconnect all remote electric power supplies before opening access panel. Unit may have multiple power supplies. Failure to disconnect all power supplies could result in personal injury or death.

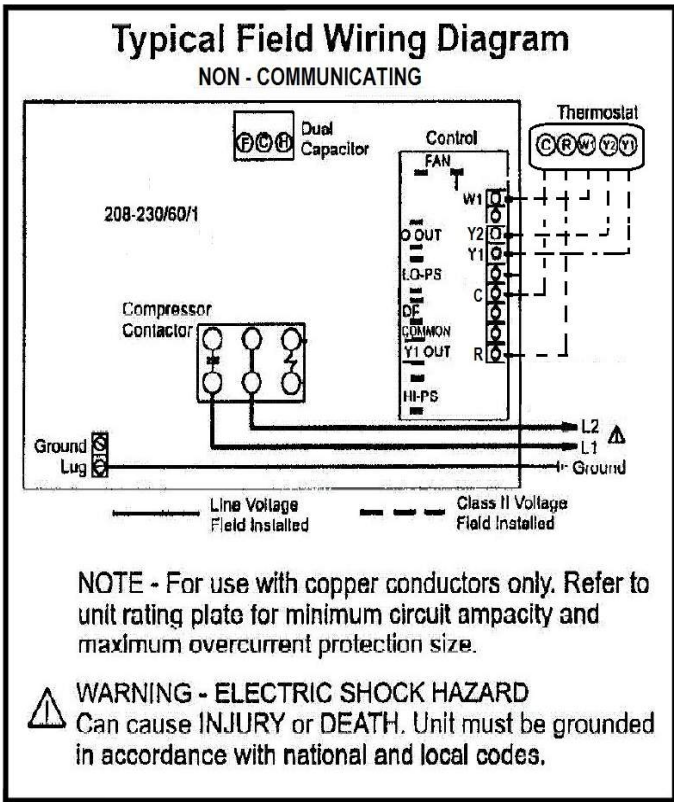

Figure 4

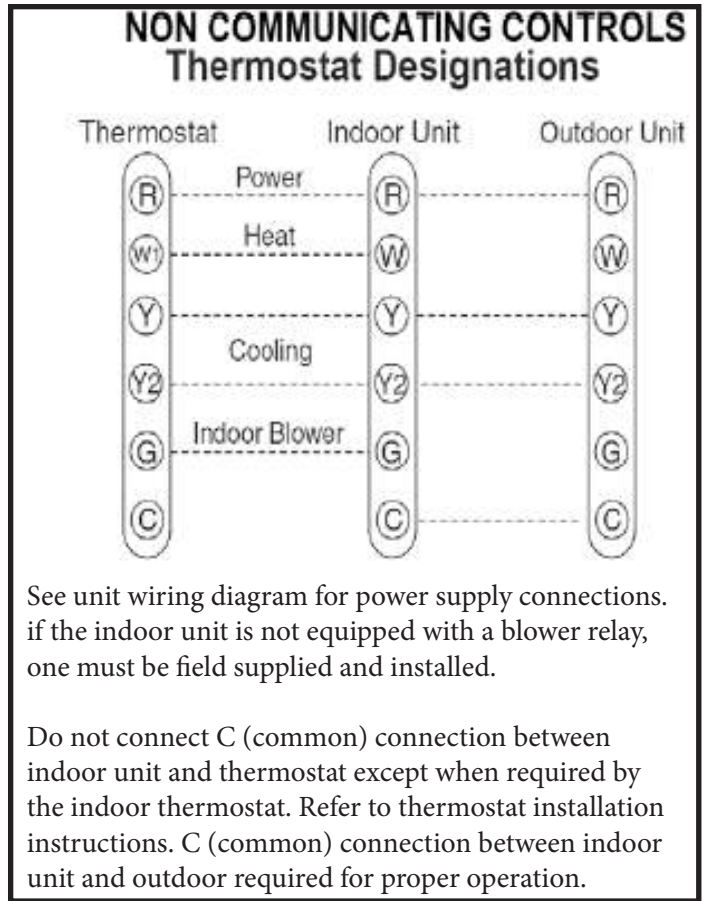

Figure 5

1. Install line voltage power supply to unit from a properly sized disconnect switch. Any excess high voltage field wiring should be trimmed or secured away from the low voltage field wiring.
2. Ground unit at unit disconnect switch or to an earth ground. To facilitate conduit, a hole is in the bottom of the control box. Connect conduit to the control box using a proper conduit fitting. Units are approved for use only with copper conductors. 24V Class II circuit connections are made in the low voltage junction box. Refer to Figure 4 for high voltage field wiring diagram. A complete unit wiring diagram is located inside the unit control box cover and in the back of this document.
3. Install room thermostat on an inside wall that is not subject to drafts, direct sunshine, or other heat sources.
4. Install low voltage wiring from outdoor to indoor unit and from thermostat to indoor unit. (See Wire Diagram on page 29.)
5. Do not bundle any excess 24V control wire inside control box. Run control wire through installed wire tie and tighten wire tie to provide low voltage strain relief and to maintain separation of field-installed low and high voltage circuits.

FIELD WIRING & ROUTING - COMMUNICATING CONTROLS

Maximum length of wiring (18 gauge) for all connections on the RSBUS is 1500 feet (457 meters). Wires should be color coded, with a temperature rating of 95°F (35°C) minimum, and solid core (Class II Rated Wiring). All low voltage wiring must enter unit through provided bushing installed in electrical inlet.

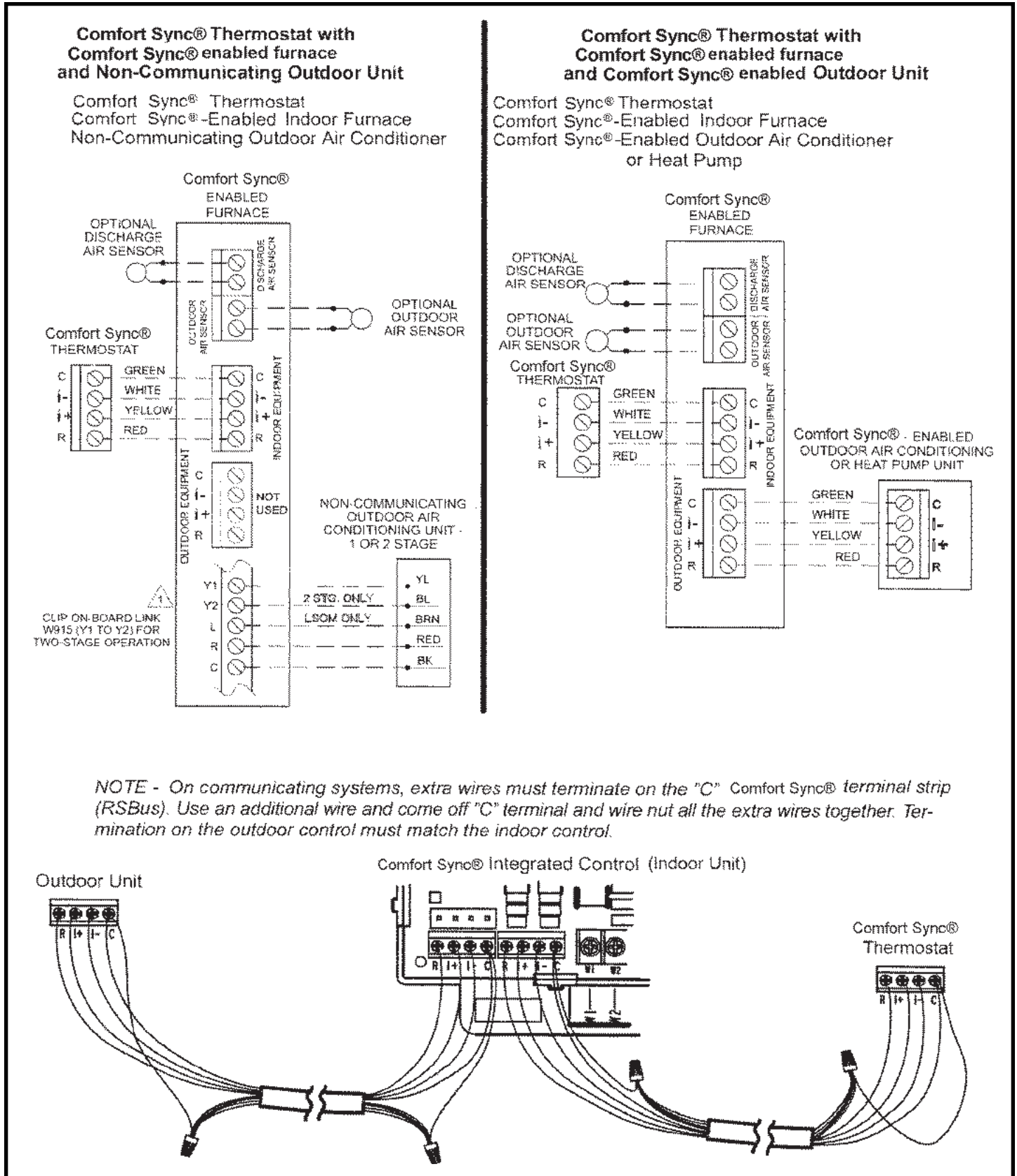

Figure 6

Following are some points to consider when placing and installing a high-efficiency outdoor unit:

Placement

Be aware that some localities are adopting sound ordinances based on how noisy the unit is at the neighbor's home, not at the original installation. Install the unit as far as possible from the property line. When possible, do not install the unit directly outside a bedroom window. Glass has a very high level of sound transmission. Figure 7 shows how to place the outdoor unit and line set to reduce line set vibration.

Line Set Isolation

Illustrations on pages 7 and 8 demonstrate procedures which ensure proper refrigerant line set isolation. Figure 8 shows how to install line sets on horizontal runs. Figure 9 shows how to make a transition from horizontal to vertical. Figure 10 shows how to install line sets on vertical runs.

Refrigerant Line Set Diameters (in.)					
Liquid Line					
Btuh	Line Set Length and Size				
	12 ft.	25 ft.	50 ft.	75 ft.	100 ft.
24,000	3/8	3/8	3/8	3/8	3/8
36,000	3/8	3/8	3/8	3/8	1/2
48,000	3/8	3/8	3/8	1/2	1/2
60,000	3/8	3/8	3/8	1/2	1/2

Suction Line					
Btuh	Line Set Length and Size				
	12 ft.	25 ft.	50 ft.	75 ft.	100 ft.
24,000	3/4	7/8	3/4	7/8	7/8
36,000	7/8	7/8	7/8	7/8	1-1/8
48,000	7/8	7/8	7/8	1-1/8	1-1/8
60,000	1/8	1/8	1-1/8	1-1/8	1-1/8

For installations exceeding 50', contact Technical Services

Table 2

2. Before making line set connections, use dry nitrogen to purge the refrigerant piping. This will help to prevent oxidation and the introduction of moisture into the system.
3. Use silver alloy brazing rods (5% or 6% silver alloy for copper-to-copper brazing or 45% silver alloy for copper-to-brass or copper-to-steel brazing) which are rated for use with R410A refrigerant.
4. Remove the Schrader core assemblies before brazing to protect them from damage due to extreme heat. Replace the cores when brazing is complete.
5. Remove light maroon washers from service valves and shield light maroon stickers to protect them during brazing. Wrap a wet cloth around the valve body and copper tube stub to protect it from heat damage.
6. Braze the line set to the service valve. Quench the joints with water or a wet cloth to prevent heat damage to the valve core and opening port. **The tube end must stay bottomed in the fitting during final assembly to ensure proper seating, sealing, and rigidity.**
7. Install the thermal expansion valve which is sold separately and which is approved for use with R410A refrigerant in the liquid line at the indoor coil (see **Refrigerant Metering Device** on page 10).

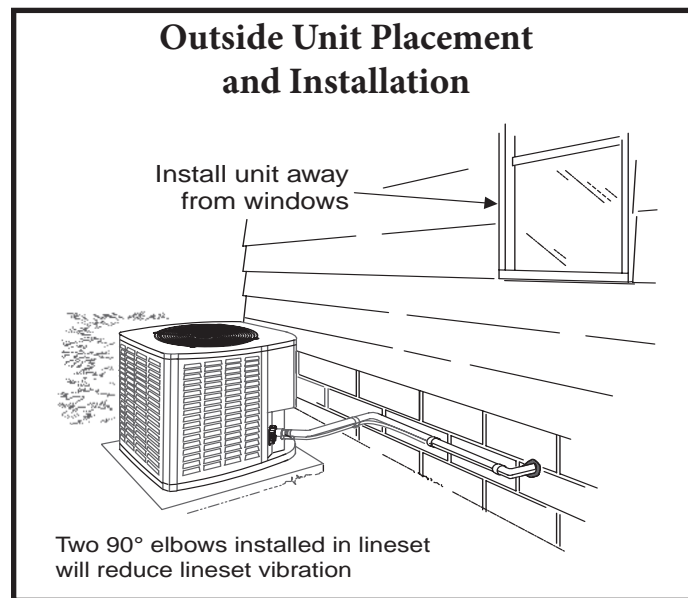

Figure 7

Brazing Connection Procedure

1. Cut ends of refrigerant lines square (free from nicks or dents). Deburr the ends. The pipe must remain round; do not pinch end of line.

Refrigerant Piping

If the 4SCU16/18LS unit is being installed with a new indoor coil and line set, the refrigerant connections should be made as outlined in this section. If an existing line set and/or indoor coil will be used to complete the system, refer to this section as well as the section that follows entitled- **Flushing Existing Line Set and Indoor Coil.**

If this unit is being matched with an approved line set or indoor coil which was previously charged with R-22 refrigerant, the line set and coil must be flushed prior to installation. If the unit is being used with an existing indoor coil which was equipped with a liquid line which served as a metering device (RFCI), the liquid line must be replaced prior to the installation of the 4SCU16/18LS unit.

Field refrigerant piping consists of liquid and suction lines from the outdoor unit (sweat connections) to the indoor coil (flare or sweat connections).

Select line set diameters from Table 2 to ensure that oil returns to the compressor. Size vertical suction riser to maintain minimum velocity at minimum capacity. Recommended line length is 50' or less. If more than 50' line set is required, contact Technical Services. Table 2 shows the diameters for line sets up to 100' although vertical lift applications and trapping requirements need to be reviewed with Technical Services for line sets over 50'.

Installing Refrigerant Line

During the installation of an air conditioning system, it is important to properly isolate the refrigerant line to prevent unnecessary vibration. Line set contact with the structure (wall, ceiling, or floor) may cause objectionable noise when vibration is translated into sound. As a result, more energy or vibration can be expected. Close attention to line set isolation must be observed.

CAUTION

When flushing existing line set and/or indoor coil, be sure to empty all existing traps. Residual mineral oil can act as an insulator, preventing proper heat transfer. It can also clog the thermal expansion valve, reducing system performance and capacity. Failure to properly flush system as explained in these instructions will void warranty.

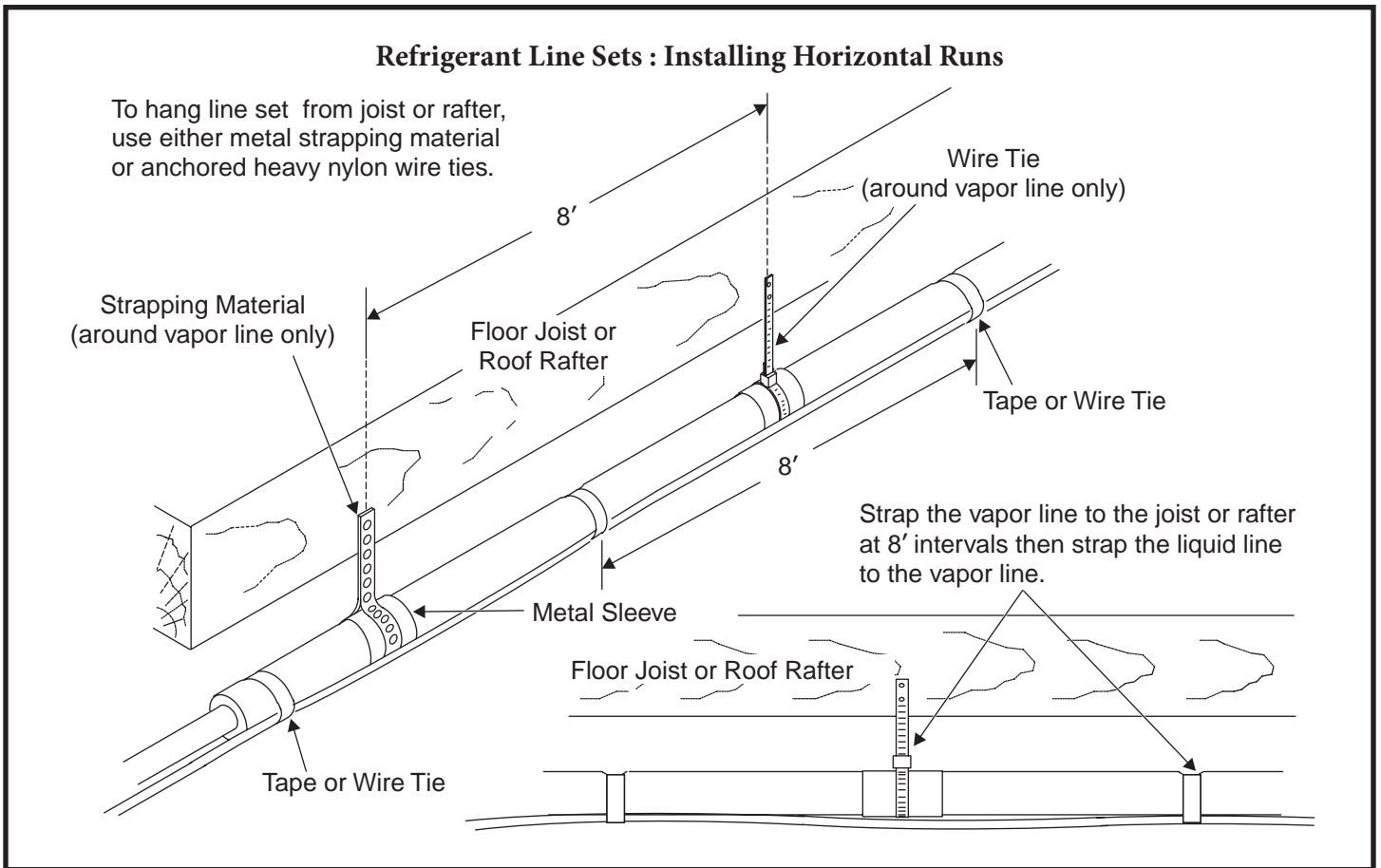

Figure 8

Refrigerant Line Sets: Transition from Vertical to Horizontal

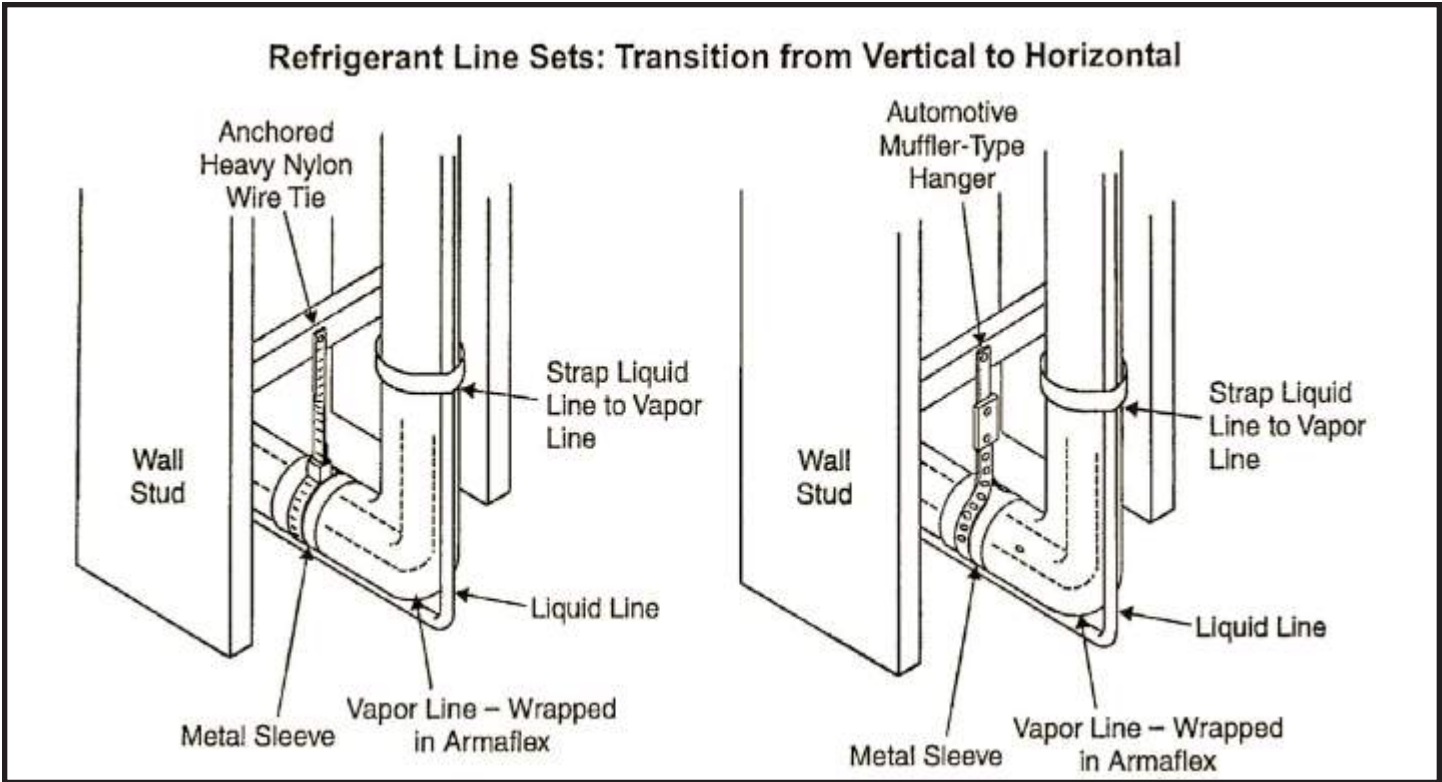

Figure 9

Refrigerant Line Sets: Installing Vertical Runs (new construction shown)

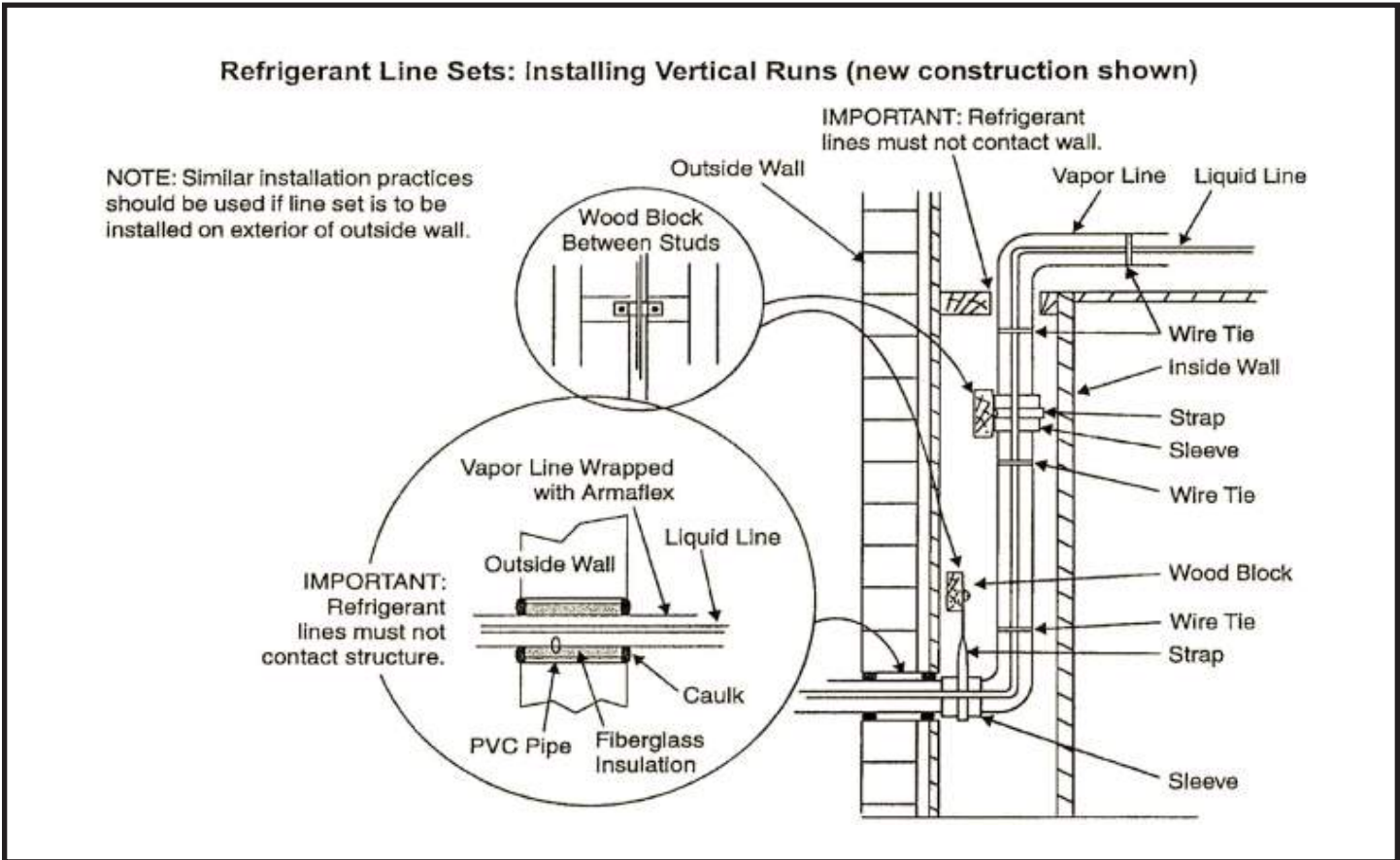

Figure 10

Flushing Existing Line Set and Indoor Coil

This procedure should not be performed on systems which contain contaminants, such as compressor burn out.

Required Equipment

The following equipment is needed to flush the existing line set and indoor coil (See Figure 11). Two clean R-22 recovery bottles, an oil-less recovery machine with a "pump down" feature, and two sets of gauges (one for use with R-22 and one for use with R-410A).

Flushing Procedure

IMPORTANT: *The line set and/or indoor coil must be flushed with at least the same amount of refrigerant that previously charged the system. Check the charge in the flushing cylinder before flushing the unit.*

1. Remove existing R-22 refrigerant using the appropriate procedure.

*If the existing outdoor unit is not equipped with shutoff valves, or if the unit is not operational AND the **existing** R-22 refrigerant will be used to flush the system:*

Disconnect all power to the existing outdoor unit. Connect the existing unit, a clean recovery cylinder, and the recovery machine according to the instructions provided with the recovery machine. Remove all R-22 refrigerant from the

existing system. Refer to the gauges after shutdown to confirm that the entire system is completely void of refrigerant. Disconnect the liquid and suction lines from the existing outdoor unit.

*If the existing outdoor unit is equipped with manual shutoff valves AND **new** R-22 refrigerant will be used to flush the system:*

Start the existing R-22 refrigerant system in cooling mode and close the liquid line valve. Pump all the existing R-22 refrigerant back into the outdoor unit.

(It may be necessary to bypass the low pressure switches to ensure complete refrigerant evacuation.)

When the low side system pressures reach 0 psig, close the suction line valve. Disconnect all power to the existing outdoor unit. Refer to the gauges after shutdown to confirm that the valves are not allowing refrigerant to flow back into the low side of the system. Disconnect the liquid and suction lines from the existing outdoor unit.

2. Remove the existing outdoor unit. Set the new R-410A unit and follow the brazing connection procedure outlined previously on this page to make line set connections. **Do not install the R-410A thermal expansion valve at this time.**

3. Make low voltage and line voltage connections to the new outdoor unit. **Do not turn on power to the unit or open the outdoor unit service valves at this time.**

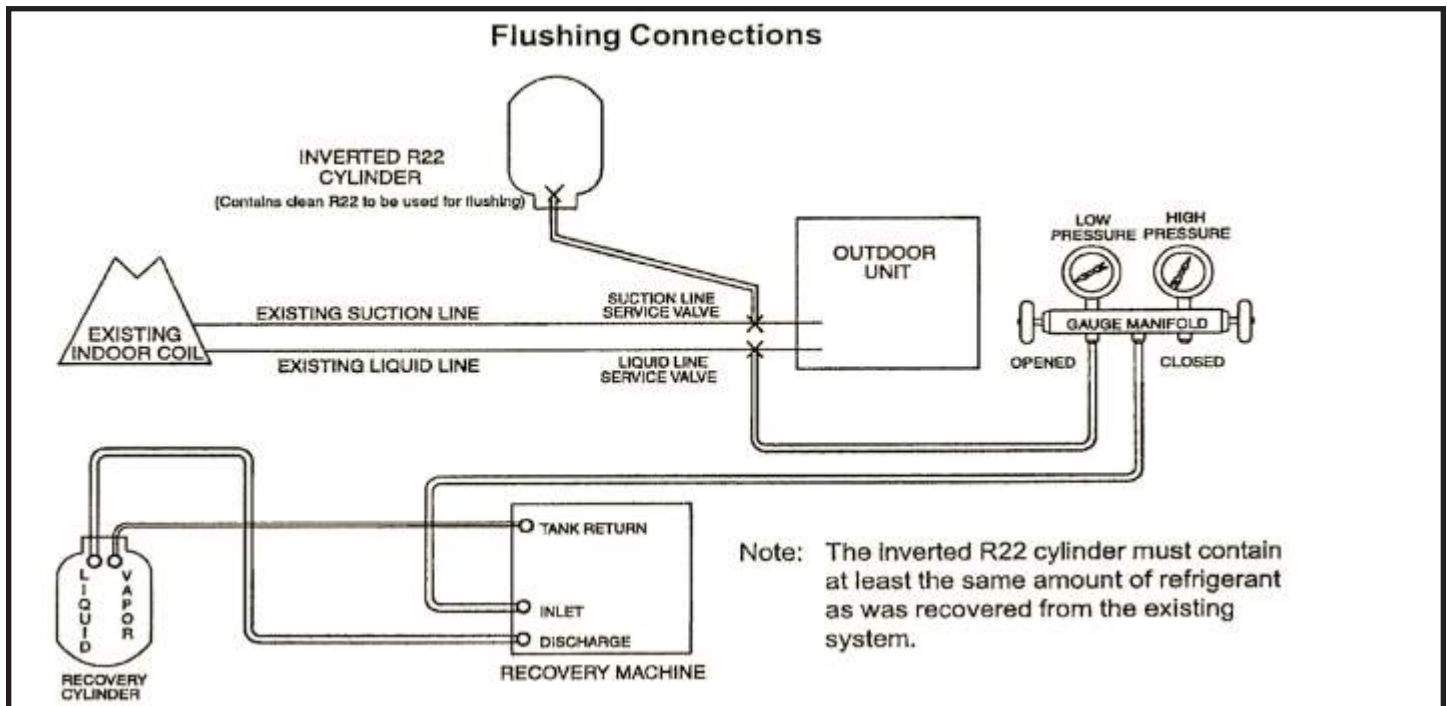

Figure 11

4. Remove the existing R-22 refrigerant flow control orifice or thermal expansion valve before continuing with flushing procedures. R-22 flow control devices are not approved for use with R-410A refrigerant and may prevent proper flushing. Use a field-provided fitting to reconnect the lines.
5. Remove the pressure tap valve cores from the 4SCU16/18LS units service valves. Connect an R-22 cylinder with clean refrigerant to the suction service valve. Connect the R-22 gauge set to the liquid line valve and connect a recovery machine with an empty recovery tank to the gauge set.
6. Set the recovery machine for liquid recovery and start the recovery machine. Open the gauge set valves to allow the recovery machine to pull a vacuum on the existing system line set and indoor coil.
7. Invert the cylinder of clean R-22 and open its valve to allow liquid refrigerant to flow in to the system through the suction line valve. Allow the refrigerant to pass from the cylinder and through the line set and the indoor coil before it enters the recovery machine.
8. After all of the liquid refrigerant has been recovered, switch the recovery machine to vapor recovery so that all of the R-22 vapor is recovered. Allow the recovery machine to pull a vacuum on the system.

NOTE: A single system flush should remove all of the mineral oil from the existing refrigerant lines and indoor coil. A second flushing may be done (using clean refrigerant) if insufficient amounts of mineral oil were removed during the first flush. **After each system flush, allow the recovery machine to pull a vacuum on the system at the end of the procedure.**

9. Close the valve on the inverted R-22 cylinder and the gauge set valves. Pump the remaining refrigerant out of the recovery machine and turn the machine off.
10. Use nitrogen to break the vacuum on the refrigerant lines and indoor coil before removing the recovery machine, gauges, and R-22 refrigerant drum. Re-install pressure tap valve cores into the 4SCU16/18LS unit's service valves.
11. Install the fixed orifice (or thermal expansion valve approved for use with R-410A refrigerant) in the liquid line at the indoor coil.

Refrigerant Metering Device

4SCU16/18LS units are designed for use with TXV systems. Refer to the appropriate following section for information on installing the chosen refrigerant metering device.

Metering Device Installation

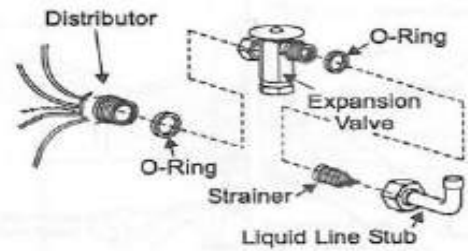

If necessary, remove R22 flow control device (fixed orifice/thermal expansion valve) from existing line set before installing R410A approved orifice or expansion valve.

Figure 12

An R410A system will not operate properly with an R-22 metering device.

Install the refrigerant metering device as shown in Figure 12. Do not twist cap tubes when loosening the seal nut from the orifice housing. Use wrench to back up the distributor.

Expansion Valve Systems

Expansion valves equipped with Chatleff-type fittings are available from the manufacturer. See Table 3 for proper TXV for each unit.

TXV Data	
Model	Part NUMBER
4SCU16LT-24-36	A4TXV01
4SCU16LT-48	A4TXV02
4SCU16LT-60	H4TXV03
4SCU18LT-18, -24, -30	A4TXV01
4SCU18LT-36, -42	A4TXV02
4SCU18LT-48, -60	H4TXV03

Table 3

To install an expansion valve (See Figure above):

1. Separate the distributor assembly and remove the piston orifice and used teflon seal. Insert nozzle end of the expansion valve along with a new teflon seal into the distributor and tighten to 20 - 30 ft. lbs. Use backup wrench on all wrench flats. **Overtightening will crush the teflon seal and may cause a leak.**
2. Attach liquid line portion of distributor assembly along with new teflon seal to the inlet of the expansion valve. Tighten to 20 - 30 ft. lbs. Use backup wrench on all wrench flats. **Overtightening will crush the teflon seal and may cause a leak.**

3. Connect the external equalizer line to the equalizer port on the suction line and tighten to 8 ft.lbs.
4. Strap the superheat sensing bulb to the suction header.

If installing an expansion valve on an indoor coil that previously used a fixed orifice, be sure to remove the existing fixed orifice. Failure to remove a fixed orifice when installing an expansion valve to the indoor coil will result in improper operation and damage to the system.

Manifold Gauge Set

Manifold gauge sets used with systems charged with R410A refrigerant must be capable of handling the higher system operating pressures. The gauges should be rated for use with pressures 1 - 800 on the high side and a low side of 30" vacuum to 250 psi with dampened speed to 500 psi. Gauge hoses must be rated for use at up to 800 psi of pressure with a 4000 psi burst rating.

Liquid and Suction Line Service Valves

The liquid line and suction line service valves (See Figure 13) and service ports are used for leak testing, evacuation, charging, and checking charge.

Each valve is equipped with a service port which has a factory-installed Schrader valve. A service port cap protects the Schrader valve from contamination and serves as the primary leak seal.

To Access the Schrader Port:

1. Remove the service port cap with an adjustable wrench.
2. Connect gauge to the service port.
3. When testing is completed, replace service port cap. Tighten finger tight, then an additional 1/6 turn.

To Open Liquid or Suction Line Service Valve:

1. Remove stem cap with an adjustable wrench.
2. Use service wrench with a hex-head extension to back the stem out counterclockwise as far as it will go. Use a 3/16" hex head extension for liquid line service valves and a 5/16" extension for suction line service valves.
3. Replace the stem cap. Tighten finger tight, then tighten an additional 1/6 turn.

To Close Liquid or Suction Line Service Valve:

1. Remove the stem cap with an adjustable wrench.
2. Use a service wrench with a hex-head extension to turn the stem clockwise to seat the valve. Tighten firmly.

3. An R410A system will not operate properly with an R-22 metering device.

Suction Line (Ball Type) Service Valve

Suction line (ball type) service valves function the same way as the other valves; the difference is in the construction (See Figure 14).

The ball valve is equipped with a service port with a factory-installed Schrader valve. A service port cap protects the Schrader valve from contamination and serves as the primary seal.

Leak Testing

After the line set has been connected to the indoor and outdoor units, the line set connections and indoor unit must be checked for leaks.

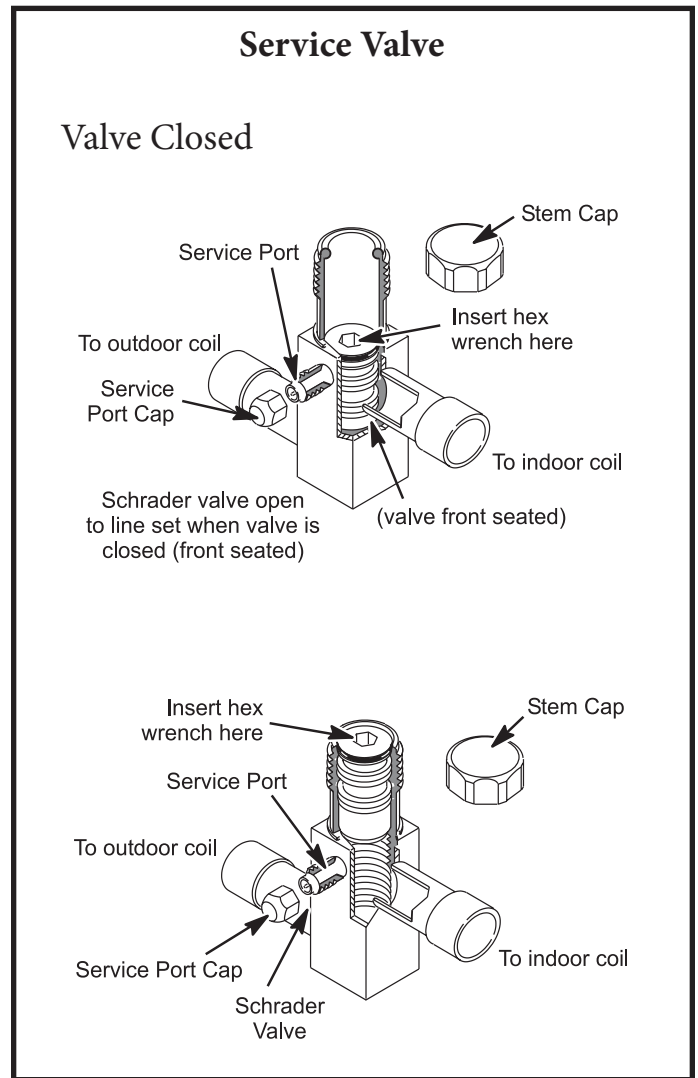

Figure 13

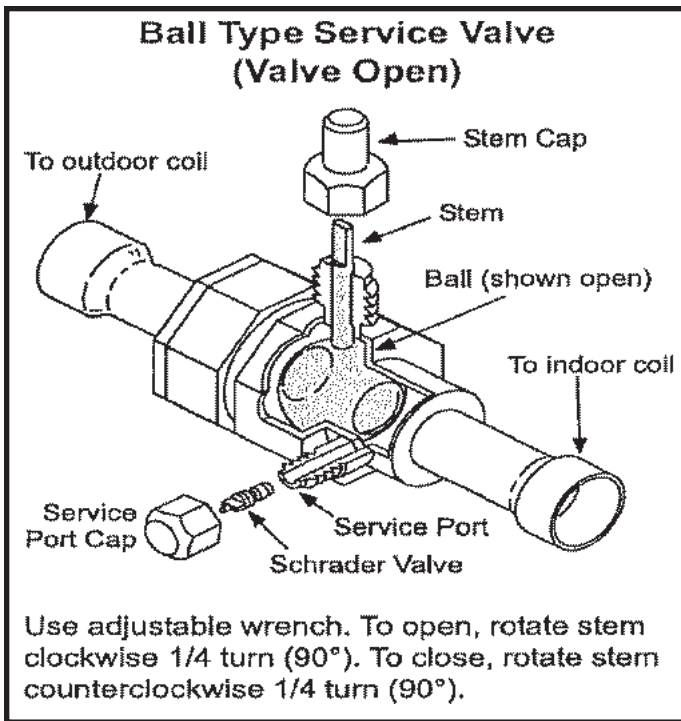

Figure 14

3. Open the high pressure side of the manifold to allow R410A into the line set and indoor unit. Weigh in a trace amount of R410A. (A trace amount is a maximum of 2 oz. of refrigerant or 3 lbs. pressure.) Close the valve on the R410A cylinder and the valve on the high pressure side of the manifold gauge set. Disconnect the R410A cylinder.
4. Connect a cylinder of nitrogen with a pressure regulating valve to the center port of the manifold gauge set. **When using high pressure gas such as nitrogen for this purpose, be sure to use a regulator that can control the pressure down to 1 or 2 psig.**
5. Adjust nitrogen pressure to 150 psig. Open the valve on the high side of the manifold gauge set to pressurize the line set and the indoor coil.
6. After a short period of time, open a refrigerant port to make sure that an adequate amount of refrigerant has been added for detection (refrigerant requirements will vary with lengths). Check all joints for leaks. Purge nitrogen and R410A mixture. Correct any leaks and rechecks.

⚠ WARNING

Refrigerant can be harmful if inhaled. Refrigerant must always be used and recovered responsibly. Incorrect or irresponsible use of refrigerant can result in personal injury or death.

⚠ WARNING

Never use oxygen to pressurize refrigeration or air conditioning systems. Oxygen will explode on contact with oil and could cause personal injury or death.

⚠ WARNING

Do not use a compressor to evacuate a system. Avoid deep vacuum operation. Extremely low vacuums can cause internal arcing and compressor failure. Danger of equipment damage. Damage caused by deep vacuum operation will void warranty.

Using an Electronic Leak Detector

1. Connect the high pressure hose of the manifold gauge set to the suction valve service port. (Normally the high pressure hose is connected to the liquid line port; however, connecting it to the suction ports helps to protect the manifold gauge set from damage caused by high pressure.)
2. With both manifold valves closed, connect the cylinder of R410A refrigerant. Open the valve on the R410A cylinder (vapor only).

Use a thermocouple or thermistor electronic vacuum gauge that is calibrated in microns. Use an instrument that reads down to 50 microns.

1. Connect the manifold gauge set to the service valve ports as follows:
 - Low pressure gauge to suction line service valve
 - High pressure gauge to liquid line service valve.
2. Connect micron gauge.

3. Connect the vacuum pump (with vacuum gauge) to the center port of the manifold gauge set.
4. Open both manifold valves and start vacuum pump.
5. Evacuate the line set and indoor unit to a minimum of 500 microns or lower. During the early stages of evacuation, it is desirable to close the manifold gauge valve at least once to determine if there is a rapid rise in pressure. A rapid rise in pressure indicates a relatively large leak. If this occurs, the leak testing procedure must be repeated.
6. When 500 microns or lower is maintained, close the manifold gauge valves, turn off the vacuum pump, and disconnect the manifold gauge center port hose from the vacuum pump. Attach the manifold gauge center port hose to a nitrogen cylinder with pressure regulator set to 150 psig and purge the hose. Open the manifold gauge valves to break the vacuum in the line set and indoor unit. Close the manifold gauge valves.
7. Shut off the nitrogen cylinder and remove the manifold gauge hose from the cylinder. Open the manifold gauge valves to release the nitrogen from the line set and indoor unit.
8. Reconnect the manifold gauge to the vacuum pump, turn the pump on, and continue to evacuate the line set and indoor unit until 500 microns is maintained within a 20 minute period after shutting off the vacuum pump and closing the manifold gauge valves.
9. When the requirements above have been met, disconnect the manifold hose from the vacuum pump. Open the service valves to break the vacuum in the line set and indoor unit.

START-UP

CAUTION

If unit is equipped with a crankcase heater, it should be energized 24 hours before unit start-up to prevent compressor damage as a result of slugging.

1. Rotate fan to check for frozen bearings or binding.
2. Inspect all factory and field-installed wiring for loose connections.
3. After evacuation is complete, open liquid line and suction line service valves to release refrigerant charge (contained in outdoor unit) into system.
4. Replace the stem caps and secure finger tight, then tighten an additional 1/6 of a turn.
5. Check voltage supply at the disconnect switch. The voltage must be within the range listed on the unit nameplate. If not, do not start equipment until the power company has been consulted and the voltage condition corrected.
6. Set thermostat for cooling demand, turn on power to indoor blower, and close the outdoor unit disconnect switch to start the unit.
7. Recheck unit voltage with unit running. Power must be within range shown on unit nameplate.

Refrigerant Charging

This system is charged with R-410A refrigerant which operates at much higher pressures than R-22. The liquid line drier provided with the unit is approved for use with R-410A. Do not replace it with one designed for use with R-22. **This unit is NOT approved for use with coils which use capillary tubes as a refrigerant metering device.**

R410A refrigerant cylinders are rose colored. Refrigerant should be added through the suction valve in the liquid state.

Certain R-410A cylinders are identified as being equipped with a dip tube. These allow liquid refrigerant to be drawn from the bottom of the cylinder without inverting the cylinder. Do not turn this type of cylinder upside down to draw refrigerant.

Units are factory charged with the amount of R410A refrigerant indicated on the unit rating plate. This charge is based on a matching indoor coil and outdoor coil with 15' line set. For varying lengths of line set, refer to Table 4 for refrigerant charge adjustment. A blank space is provided on the unit rating plate to list the actual field charge.

Refrigerant Charge Adjustment

Liquid Line Set Diameter	Oz. Per 5 ft. adjust from 15 ft. line set*
3/8 in.	3 oz. per 5 ft.

* If line length is greater than 15 ft. , add this amount.
If line length is less than 15 ft., remove this amount.

Table 4

IMPORTANT

Mineral oils are not compatible with R-410A. If oil must be added, it must be a polyolester oil.

If the system is void of refrigerant, clean the system using the procedure described below.

1. Use dry nitrogen to pressurized the system and check for leaks. Repair leaks, if possible.
2. Evacuate the system to remove as much of the moisture as possible.
3. Use dry nitrogen to break the vacuum.
4. Evacuate the system again.
5. Weigh the appropriate amount of R-410A refrigerant (listed on unit nameplate) into the system.
6. Monitor the system to determine the amount of moisture remaining in the oil. Use a test kit to verify that the moisture content is within the kit's dry color range. It may be necessary to replace the filter drier several times to achieve the required dryness level. **If system dryness is not verified, the compressor will fail in the future.**

The outdoor unit should be charged during warm weather. However, applications arise in which charging must occur in the colder months. The method of charging is determined by the unit's **refrigerant metering device** and the **outdoor ambient temperature**.

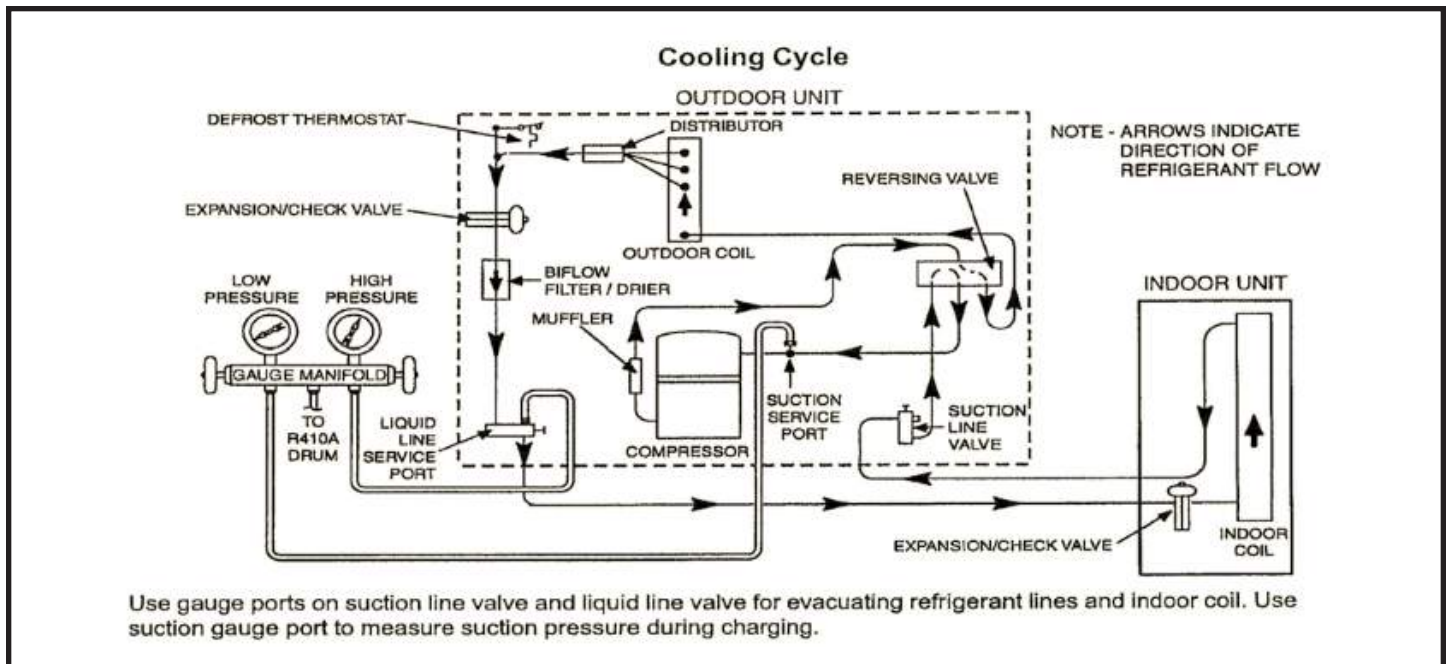

Figure 15

Measure the liquid line temperature and the outdoor ambient temperature as outlined below:

1. Connect the manifold gauge set to the service valve ports as follows (See Figure 15 above):

- Low pressure gauge to suction line service valve
- High pressure gauge to liquid line service valve

2. Close manifold gauge set valves. Connect the center manifold hose to an upright cylinder of R-410A.
3. If room temperature is below 70°F, set the room thermostat to call for heat. This will create the necessary load for properly charging the system in the cooling cycle.
4. Use a digital thermometer to record the outdoor ambient temperature.
5. When the heating demand has been satisfied, switch the thermostat to cooling mode with a set point of 68°F. When pressures have stabilized, use a digital thermometer to record the liquid and suction line temperatures.
6. The outdoor temperature will determine which charging method to use. Proceed with the appropriate charging method.

Charge Using Weigh-In Method (Fixed Orifice/TXV Systems) - Outdoor Temperatures Below 65°F

If the system is void of refrigerant, or if the outdoor ambient temperature is cool, use the weigh-in method to charge the unit. Do this after any leaks have been repaired.

1. Recover the refrigerant from the unit.
2. Conduct a leak check, then evacuate as previously outlined.
3. Weigh in the charge according to the total amount shown on the unit nameplate.

If weighing facilities are not available or if unit is being charged during warm weather, use one of the following procedures.

Charge Using Subcooling Method (Fixed Orifice/TXV Systems) - Outdoor Temperatures 65°F or Above

If charging a fixed orifice or TXV system when the outdoor ambient temperature is 65°F or above, the subcooling method can be used to charge the unit.

1. With the manifold gauge hose still on the liquid service port and the unit operating stably, use a digital thermometer to check the liquid line temperature. For best results, use the same digital thermometer to check both the outdoor ambient and the liquid line temperatures.
2. At the same time, record the liquid line pressure reading.
3. Use the temperature/pressure chart (Table 5) to determine the saturation temperature for the liquid line pressure reading.
4. Subtract the liquid line temperature from the saturation temperature (according to the chart) to determine subcooling.

R-410A Temperature/Pressure Chart

Temp. °F	Pressure Psig	Temp. °F	Pressure Psig	Temp. °F	Pressure Psig
32	100.8	74	214.0	116	396.0
33	102.9	75	217.4	117	401.3
34	105.0	76	220.9	118	406.7
35	107.1	77	224.4	119	412.2
36	109.2	78	228.0	120	417.7
37	111.4	79	231.6	121	423.2
38	113.6	80	235.3	122	428.8
39	115.8	81	239.0	123	434.5
40	118.0	82	242.7	124	440.2
41	120.3	83	246.5	125	445.9
42	122.6	84	250.3	126	451.8
43	125.0	85	254.1	127	457.6
44	127.3	86	258.0	128	463.5
45	129.7	87	262.0	129	469.5
46	132.2	88	266.0	130	475.6
47	134.6	89	270.0	131	481.6
48	137.1	90	274.1	132	487.8
49	139.6	91	278.2	133	494.0
50	142.2	92	282.3	134	500.2
51	144.8	93	286.5	135	506.5
52	147.4	94	290.3	136	512.9
53	150.1	95	295.1	137	519.9
54	152.8	96	299.4	138	525.8
55	155.5	97	303.8	139	532.4
56	158.2	98	308.2	140	539.0
57	161.0	99	312.7	141	545.6
58	163.9	100	317.2	142	552.3
59	166.7	101	321.8	143	559.1
60	169.6	102	326.4	144	565.9
61	172.6	103	331.0	145	572.8
62	175.5	104	335.7	146	579.8
63	178.5	105	340.5	147	586.8
64	181.6	106	345.3	148	593.8
65	184.3	107	350.1	149	601.0
66	187.7	108	355.0	150	608.1
67	190.9	109	360.0	151	615.4
68	194.1	110	365.0	152	622.7
69	197.3	111	370.0	153	630.1
70	200.6	112	375.1	154	637.5
71	203.9	113	380.2	155	645.0
72	207.2	114	385.4		
73	210.6	115	390.7		
72	207.2	114	385.4		
73	210.6	115	390.7		

Table 5

- ° Saturation Temperature °F
- — ° Liquid Line Temperature °F
- = — ° Subcooling Value °F

5. Compare the subcooling value with those shown in Table 6. If subcooling is greater than shown, recover some refrigerant. If subcooling is less than shown, add some refrigerant.

Subcooling Values					
	Model	-24	-36	-48	-60
4SCU16	Temp. °F	5	6	6	9
4SCU18	Temp. °F	6	6	6	6

Table 6

Charge Using Approach Method (TXV System) - Outdoor Temperatures 65°F or Above

The following procedure is intended as a general guide and is for use on expansion valve systems only. For best results, indoor temperature should be 70°F to 80°F. Monitor system pressures while charging.

1. Record outdoor ambient temperature using a digital thermometer.
2. Attach high pressure gauge set and operate unit for several minutes to allow system pressures to stabilize.
3. Compare stabilized pressures with those provided in Table 8. Minor variations in these pressures may be expected due to differences in installations. **Significant differences could mean that the system is not properly charged or that a problem exists with some component in the system.** Pressures higher than those listed indicate that the system is overcharged. Pressures lower than those listed indicate that the system is undercharged. Verify adjusted charge using the approach method.
4. Use the same digital thermometer to check liquid line temperature.
5. Subtract the outdoor ambient temperature from the liquid line temperature to determine the approach temperature.

OPERATION

- _____ ° Liquid Line Temperature °F
- _____ ° Outdoor Ambient Temperature °F
- = _____ ° Approach Temperature °F

6. Compare the approach value with those shown in Table 7.
7. If the values do not agree with those provided in Table 7, add refrigerant to lower the approach temperature or recover refrigerant from the system to increase the approach temperature.

Check Charge Using Normal Operating Pressures

Use Table 8 to perform maintenance checks. Table 8 is not a procedure for charging the system. Minor variations in these pressures may be due to differences in installations. Significant deviations could mean that the system is not properly charged or that a problem exists with some component in the system.

Approach Values for TXV Systems

	Model	-24	-36	-48	-60
4SCU 16	Temp. °F	8	10	8	4
4SCU 18	Temp. °F	1	2	1	5

Approach value is the liquid line temperature minus the outdoor ambient temperature (1°F).

NOTE: For best results, use the same digital thermometer to check both outdoor ambient and liquid temperatures

Table 7

Outdoor unit and indoor blower cycle on demand from the room thermostat. When the thermostat blower switch is moved to the ON position, the indoor blower operates continuously.

Filter Drier

The unit is equipped with a large capacity bi-flow filter which keeps the system clean and dry. If replacement is necessary, replace with one of similar design and capacity. The replacement filter drier must be suitable for use with R410A refrigerant.

Crankcase Heater

If unit is equipped with a crankcase heater, it should be energized 24 hours before unit start-up to prevent compressor damage as a result of slugging.

Emergency Heat Function (Room Thermostat)

An emergency heat function is designed into some room thermostats. This feature is applicable when isolation of outdoor unit is required or when auxiliary electric heat is stage by outdoor thermostats. When the room thermostat is placed in the emergency heat position, the outdoor unit control circuit is isolated from power and the field-supplied relays bypass the outdoor thermostats. An amber indicating light simultaneously comes on to remind the homeowner that the unit is operating in the emergency heat mode.

Emergency heat is usually used during an outdoor shutdown, but it should also be used following a power outage if power has been off for over an hour and the outdoor temperature is below 50°F. System should be left in the emergency heat mode at least 6 hours to allow the crankcase heater sufficient time to prevent compressor slugging.

Normal Operating Pressures								
1st Stage (Low Capacity)								
Outdoor Coil Entering Air Temp. °F	4SCU16-24		4SCU16-36		4SCU16-48		4SCU16-60	
	L	S	L	S	L	S	L	S
65	244	136	238	133	247	130	250	125
75	283	138	278	135	281	134	291	127
85	326	141	324	137	325	137	334	130
95	376	142	374	139	386	139	383	133
105	428	144	429	142	428	141	434	136
115	486	146	500	144	485	144	489	139

2nd Stage (High Capacity)								
Outdoor Coil Entering Air Temp. °F	4SCU16-24		4SCU16-36		4SCU16-48		4SCU16-60	
	L	S	L	S	L	S	L	S
65	249	126	251	129	249	123	243	117
75	288	133	291	135	286	129	285	123
85	331	138	334	139	328	133	329	129
95	379	143	383	143	372	137	376	134
105	425	147	435	147	419	141	427	137
115	481	150	490	150	475	145	485	141

1st Stage (Low Capacity)								
Outdoor Coil Entering Air Temp. °F	4SCU18-24		4SCU18-36		4SCU18-48		4SCU18-60	
	L	S	L	S	L	S	L	S
65	205	140	203	139	196	142	236	132
75	247	142	242	141	240	144	278	136
85	288	145	287	144	294	149	321	140
95	330	147	344	147	348	150	363	144
105	372	148	391	149	402	151	405	148
115	413	151	438	153	456	154	447	152

2nd Stage (High Capacity)								
Outdoor Coil Entering Air Temp. °F	4SCU18-24		4SCU18-36		4SCU18-48		4SCU18-60	
	L	S	L	S	L	S	L	S
65	212	137	210	141	237	137	248	123
75	254	139	247	143	286	139	293	128
85	295	142	298	145	330	140	337	132
95	337	144	349	147	374	142	382	137
105	379	146	400	149	418	144	427	142
115	424	149	451	151	462	145	471	146

L- Liquid S- Suction

Values provided above are typical pressures. Indoor unit matchup, indoor air quality equipment, and indoor load will cause pressure to vary.

Table 8

CONTROL BOARD

Communication System

The jumper settings and link are default settings and ONLY control system operation if configuration settings in the Comfort Sync thermostat are not available.

The Comfort Sync thermostat must be used in communicating applications.

Non-Communicating System

The unit will operate based on jumper settings and R TO DS link on the MAIN CONTROL. All unit setting changes must be done at the MAINCONTROL. A non-communicating electronic-only thermostats may be used.

NOTE — Fan cycling routine when activated will cycle the fan ON for five minutes if the outdoor ambient air temperature is between 15°F and 35°F and the compressor has been OFF for 25 to 30 minutes. This option is to help reduce the potential for ice build up on the orifice ring during system OFF cycles that are greater than 25 to 30 minutes.

Set up of jumpers on replacement outdoor control.

(HP ONLY) J4
COMPRESSOR SHIFT DELAY

30
SECOND DELAY
(DEFAULT)

0
SECOND DELAY

(TWO-STAGE HEAT PUMP ONLY) J2
SECOND-STAGE LOCK-IN TEMPERATURE

55
DEGREE
TARGET

50
DEGREE
TARGET

45
DEGREE
TARGET

40
DEGREE
TARGET (DEFAULT)

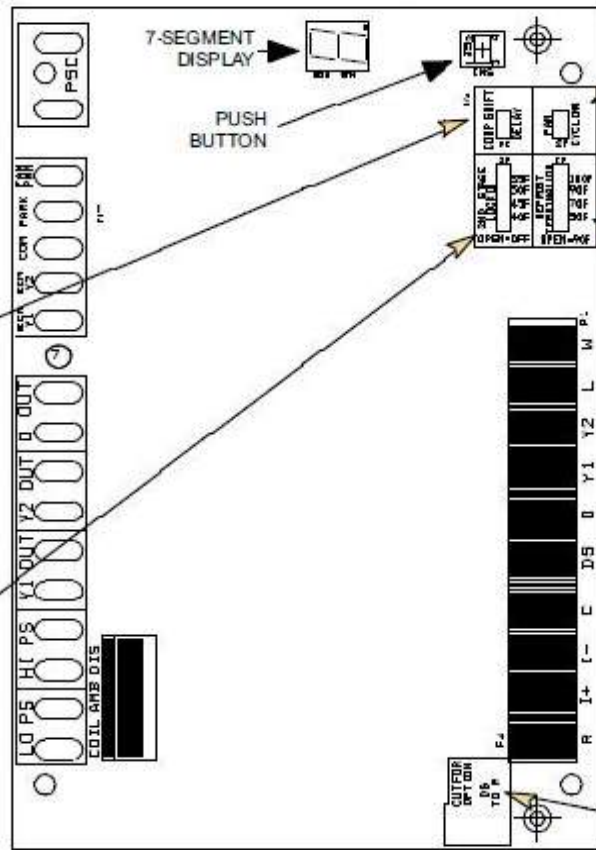

J3 ALL UNITS)
FAN DE-ICING

JUMPER ON
FAN ON FOR 5 MINUTES

JUMPER OFF
DISABLE (DEFAULT)

SEE NOTE ABOVE FOR FURTHER DETAILS.

J1 (HP ONLY)
DEFROST TERMINATION TEMPERATURE

100
DEGREE
TARGET

90
DEGREE
TARGET

75
DEGREE
TARGET

50
DEGREE
TARGET
(DEFAULT)

(DEFAULT WHEN JUMPER IS REMOVED OR MISSING)

DS TO R TWO-STAGE UNIT ONLY)
Cut for Comfort Sync- Enhanced Dehumidification Accessory (EDA) applications.
NOTE - LINK NOT APPLICABLE TO ONE-STAGE UNITS. CUTTING LINK WILL

MANDATORY CONFIGURATION REQUIREMENTS — HEAT PUMP CONTROL — TWO-STAGE OPERATION

1. Set defrost termination temperature (J1) to ensure a completely clear coil before termination of defrost. Low outdoor temperatures could require higher defrost termination temperature setting. Factory default setting is 50°F. If jumper is removed or missing, default is 90°F.

IMPORTANT — All mandatory configuration requirements (jumpers and link) **MUST** be completed prior to starting unit.

2. Second-stage lock-in factory default setting for J2 is 40°F. If jumper is removed or missing, default is OFF.

Figure 14

Operation

Outdoor unit and indoor blower cycle on demand from the room thermostat. When the thermostat blower switch is moved to the ON position, the indoor blower operates continuously.

Time Delay

The timed-off delay is 5 minutes long. The delay helps to protect the compressor from short cycling in case the power to the unit is interrupted or a pressure switch opens.

Pressure Switch Circuit

The control includes two pressure switch circuits. A high pressure switch is connected to the board's HI-PS terminals (See Figure 16). The low pressure, or loss-of-charge pressure, switch is connected to the LO-PS terminals.

During a single demand cycle, the defrost control will lock out the unit after the fifth time that the circuit is interrupted by an pressure switch wired to the control board. In addition, the diagnostic LEDs will indicate a locked-out pressure switch after the fifth occurrence of an open pressure switch.

The unit will remain locked out until power to the board is interrupted, then re-established, or until the error is cleaned.

NOTE: *The control board ignores input from the low pressure switch terminals as follows:*

- During the TEST mode
- During the 90 seconds start-up period

Fan Cycling (J3)

Fan cycling routine when activated will cycle the fan ON (see figure 14) for five minutes if the outdoor ambient air temperature is between 15°F and 35°F and the compressor has been OFF for 25 to 30 minutes. This option is to help reduce the potential for ice build up on the orifice ring during system OFF cycles that are greater than 25 to 30 minutes.

Seven-Segment Alert and System Status Codes

Alert codes are displayed using the seven segment display located on the outdoor control.

NOTE: System fault and lockout alarm code displays takes precedence over system status (cooling, heating stages or defrost/dehumidification).

The seven segment will display an abnormal condition (error code) when detected in the system. A list of the codes are shown in Table 9.

Re-Setting Alert Codes

Alert codes can be reset manually or automatically:

Manual Reset

Manual reset can be achieved by one of the following methods:

- Disconnecting R wire from the main control's R terminal.
- Turning the indoor unit off and back on again. After power up all existing code will display 60 seconds and then clear.

Automatic Reset

After an alert is detected, the main control continues to monitor the unit's system and compressor operations. When/if conditions return to normal, the alert code is turned off automatically.

Seven-Segment Display Alert Codes

NOTE - System fault and lockout seven - segment display alarm codes takes precedence over system status codes (cooling, heating stages or defrost/dehumidification). Only the latest active fault or lockout alarm code if present will be displayed. If no fault or lockout codes are active, then system status are routinely displayed.

Alert Codes	Priority	Alarm Description	Possible Causes and Clearing Alarm
E105	Critical	The outdoor unit has lost communication with the rest of the system.	Equipment is unable to communicate. This may indicate the existence of other alarms / codes. In most cases errors are related to electrical noise. Make sure high voltage power is separated from RSBUS. Check for mis-wired and/or loose connections between the stat, indoor unit and outdoor unit. Check for a high voltage source of noise close to the system. This is a self-recoverable error.
E120	Moderate	There is a delay in the outdoor unit responding to the system.	Typically, this alarm/code does not cause any issues and will clear on its own. The alarm / code is usually caused by a delay in the outdoor unit responding to the thermostat. Check all wiring connections. Cleared after unresponsive device responds to any inquiry
E124	Critical	The Comfort Sync thermostat has lost communication with the outdoor unit for more than 3 minutes.	Equipment lost communication with the thermostat. Check the wiring connections, ohm wires and cycle power. The alarm stops all associated HVAC operations and waits for a heartbeat message from the unit that's not communicating. The alarm / fault clears after communication is re-established.
E125	Critical	There is a hardware problem with the outdoor unit control.	There is a control hardware problem. Replace the outdoor control if the problem prevents operation and is persistent. The alarm / fault is cleared 300 seconds after the fault recovers
E126	Critical	There is an internal communication problem with the outdoor unit control.	There is an internal hardware problem on the control. Typically the control will re-set itself. Replace the control if the problem prevents operation and is persistent. The alarm / fault is cleared 300 seconds after the fault recovers.
E131	Critical	The outdoor unit control parameters are corrupted	Reconfigure the system. Replace the control if heating or cooling is not available
E180	Critical	The Comfort Sync thermostat has found a problem with the outdoor unit's ambient sensor.	In normal operation after outdoor control recognizes sensors, the alarm will be sent if valid temperature reading is lost. Compare outdoor sensor resistance to temperature/resistance charts in unit installation instructions. Replace sensor pack if necessary. At the beginning of (any) configuration, furnace or air-handler control will detect the presence of the sensor(s). If detected (reading in range), appropriate feature will be set as 'installed' and shown in the Comfort Sync 'About' screen. The alarm / fault will clear upon configuration, or sensing normal values.
E409	Moderate	The secondary voltage for the outdoor unit has fallen below 18VAC. If this continues for 10 minutes, the system will shut down.	Secondary voltage is below 18VAC. After 10 minutes, operation is discontinued. Check the indoor line voltage, transformer output voltage. The alarm clears after the voltage is higher than 20VAC for 2 seconds or after a power reset.
E410	Moderate	The outdoor unit pressure is below the required limit.	Unit pressure is below the lower limit. The system is shutdown. The low pressure switch for HFC-410A will open at 40PSIG and close at 90PSIG. Confirm that the system is properly charged with refrigerant. Check TXV, indoor unit blower motor, dirty filters or clogged refrigerant filter. Confirm that the evaporator coil is clean. The alarm clears after the pressure switch closes or after a power reset
E411	Critical	The low pressure switch has opened 5 times during one cooling cycle. As a result, the system will shutdown.	Open low pressure switch error count reached 5 strikes. The low pressure switch for R410A will open at 40PSIG and close at 90PSIG. Confirm that the system is properly charged with refrigerant. Check TXV, indoor unit blower motor, dirty filters or clogged refrigerant filter. Confirm that the evaporator coil is clean. The alarm clears after a power reset
E412	Moderate	The outdoor unit pressure is above the required limit. The system will shut down.	Unit pressure is above the upper limit. System is shut down. The high pressure switch for HFC-410A will open at 590PSIG and close at 418PSIG. Confirm that the system is properly charged with refrigerant. Check condenser fan motor, TXV, indoor unit blower motor, stuck reversing valve or clogged refrigerant filter. Confirm that the outdoor unit is clean. The alarm clears after 4 consecutive normal compressor run cycles, the pressure switch closes or a power reset
E413	Critical	The high pressure switch has opened 5 times during one cooling cycle. As a result, the Comfort Sync thermostat will shutdown.	Open high pressure switch error count reached 5 strikes. System is shut down. The high pressure switch for HFC-410A will open at 590PSIG and close at 418PSIG. Confirm that the system is properly charged with refrigerant. Check condenser fan motor, TXV, indoor unit blower motor, stuck reversing valve or clogged refrigerant filter. Confirm that the outdoor unit is clean. The alarm clears after a power reset.
E414	Moderate	The discharge line temperature is higher than the recommended upper limit of 279°F.	Discharge line temperature is > 279°F. Confirm that the system is properly charged with refrigerant. Check system operating pressures and compare to unit charging charts in installation manual. Confirm that the outdoor unit is clean. The alarm clears after the discharge temperature is < 225°F.
E415	Critical	The discharge line temperature has been consistently higher than the recommended upper limit of 279°F.	Discharge line high temperature error count reached 5 strikes. Confirm that the system is properly charged with refrigerant. Check system operating pressures and compare to unit charging charts in installation manual. Confirm that the outdoor unit is clean. The alarm clears after the discharge temperature is < 225°F. The alarm clears after a power reset.

Table 9

Table 9. Seven-Segment Display Alert Codes (continued)

Alert Codes	Priority	Alarm Description	Possible Causes and Clearing Alarm
E416	Critical	The outdoor coil sensor is either open, short circuited or the temperature is out of sensor range. As a result the outdoor unit control will not perform any defrost tempering.	Coil sensor being detected open or shorted, or temperature is out of coil sensor range. Outdoor unit control will not perform demand or time/temperature defrost operation. System will still heat or cool. Check the resistance of the coil sensor and compare to temperature resistance chart. Replace coil sensor if needed. The alarm clears when outdoor unit control detects proper coil sensor readings or after a power reset.
E417	Critical	The outdoor unit discharge sensor is either open, short circuited or the temperature is out of sensor range. As a result the outdoor unit control will not perform any defrost tempering.	Outdoor unit control detects open or shorted discharge sensor, or temperature that is out of discharge sensor range. Check the resistance of the discharge sensor and compare to temperature resistance chart replace if needed. Reset by replacing the discharge sensor. This fault is detected by allowing the unit to run for 90 seconds before checking discharge sensor resistance. If the discharge sensor resistance is not within range after 90 seconds, the board will count one fault. After 5 faults, the board will lock out. Check for proper sensor reading and attachment to line. The alarm clears after a power reset.
E418	Moderate	There is a faulty W output circuit.	Faulty W output circuit. Confirm that the unit is not running. Check for miswiring. Disconnect thermostat lines from W and verify 24VAC on the W . If 24VAC is present, replace the board.
E419	Critical	The W output on the outdoor unit has reported more than 5 errors. As a result, the system has shutdown the outdoor unit.	W output hardware fault count reached 5 strikes.
E420	Critical	The heat pump defrost cycle has taken more than 20 minutes to complete.	Defrost cycle lasts longer than 20 minutes. This alarm is applicable with non-communicating heat pump system only. Check heat pump defrost operation. The alarm is cleared after the "W1" signal is removed.
E421	Critical	The W output terminal on the outdoor unit is not wired correctly.	Voltage sensed on W and O when Y1 thermostat input is deactivated. Another device or wiring fault is energizing W Check wiring. The alarm clears when wiring is corrected or after a power reset

NOTE: Additional codes may be found in Comfort Sync room thermostat manual.

Table 10. Outdoor Control Seven-Segment Unit Status Displays

Description	Example of Display
<p>Power up / Reset: Unit type and number of stages is displayed. Verify configuration with information published on the unit nameplate. If the information is incorrect, refer to flow chart Manually Configuration of Unit Type to re-configure control.</p>	<p>1 Stage AC: 1AC 2 Stage AC: 2AC 1 Stage AC: 1HP 1 Stage AC: 2HP</p> <p>POWER-UP 7-SEGMENT DISPLAY STRING</p> <p>Unit Type / Stages No Capacity No Fan Profile</p>
<p>Power up / Reset following display of self-discovered configuration: Unit nominal capacity is displayed, if not programmed then three horizontal lines and the decimal point are displayed for 2 seconds.</p>	<p>Power up nominal capacity display of an 4SHP - LS136</p> <p>POWER-UP 7-SEGMENT DISPLAY STRING</p> <p>Unit Type / Stages Capacity No Fan Profile</p>
<p>Power up / Reset following display of nominal capacity: Fan Profile code. (a single or two digit number) See table 5 for applicable fan RPM profile.</p>	<p>Displays the number of the selected fan profile. 3 *</p> <p>POWER-UP 7-SEGMENT DISPLAY STRING</p> <p>Unit Type / Stages Capacity Fan Profile</p>

Table 10. Outdoor Control Seven-Segment Unit Status Displays (continued)

Description	Example of Display
Idle Mode: Decimal point blinks at 1 Hz	Idle Mode: Decimal point blinks at 1 Hz (0.5 second on, 0.5 second off). Display OFF.
Soft Disabled: Top and bottom horizontal line and decimal point blink at 1 Hz.	Soft Disabled: Top and bottom horizontal line and decimal point blink at 1 Hz (0.5 second on, 0.5 second off). Note: Control should be replaced.
O.E.M test mode	All segments flashing at 2 Hz (unless error is detected) Note: Control should be replace.
Anti - Short Cycle Delay	Middle line shall blink at 1 Hz for 2 seconds, followed by a 2 second display of the rounded up number of minutes left in the timer (2 minutes 1 second shall be displayed as 3"). The Anti - Short Cycle Delay time remaining is displayed whenever the delay is active.
Cooling Stage: Shows what stage of cooling is currently operating.	Following string is repeated if second stage cooling is active with outdoor fan speed set at 700 RPM. Note: A displays outdoor ambient temperature. C 2 pause F 7 0 0 pause*
Heat Pump Stage: Shows what stage of heat pump is currently operating.	Following string is repeated if first stage heat pump is active with outdoor fan speed set at 600 RPM. Note: A displays outdoor ambient temperature. H 1 pause F 6 0 0 pause*
Defrost Mode: Shown only while in an active defrost.	Following string is repeated if defrost is active while unit was in 1st stage heat d F pause H 1 pause
Dehumidification mode: Shows that the unit is providing dehumidification instead of straight cooling.	Following string is repeated if dehumidification is active with outdoor fan speed set at 225 RPM: d pause F 2 2 5 pause*
Diagnostic recall: Shows the last 10 stored diagnostic error codes.	If first error is E250 , second E231 : E pause 2 5 0 pause E pause 2 3 1 Next codes (up to 10) are show using same method.
Fault Memory clear	If there is no error codes stored: E pause 0 0 0 After the fault memory is cleared following string is displayed with 0.5 seconds character on/off time: 0 0 0 0 pause
Active error in outdoor control Idle mode: Shown all active error(s) codes.	Following string is repeated if Error E125 and E201 are present: E 1 2 5 pause E 2 0 1
Active error in run mode: Shown current status and all active error(s) codes.	Following string is repeated if Error E311 is present while blower speed at 700RPM: F 7 0 0* pause E 3 1 1
Outdoor Ambient Temperature (OAT): Any time OAT is sensed in operating range value is displayed if unit is in diagnostic and non - diagnostic modes.	Following string is repeated if second stage cooling is active with outdoor fan speed set at 650 RPM and OAT is 104°F : C 2 pause F 6 5 0* pause A 1 0 4 pause
Outdoor Coil Temperature (OCT): Any time OCT is sensed in operating range value is displayed if unit is in diagnostic mode.	Following string is repeated if 2nd stage heat is active with outdoor fan speed set at 550 RPM and OCT is 25°F : H 2 pause F 5 5 0* pause c 2 5 pause
Discharge Line Temperature (DIS): Any time DIS is sensed in operating range value is displayed if unit is in diagnostic mode.	Following string is repeated if 2nd stage cooling is active with outdoor fan speed set at 650 RPM and DIS is 185°F : C 2 pause F 6 5 0* pause D 1 8 5 pause

*** Information will be displayed but does not apply to this unit does**

Table 11. Error Recall Menu Options

Error Code Recall Mode (Note - control must be in idle mode)		
Solid	E	To enter error code recall mode, push and hold button until solid E appears, then release button. Control will display up to 10 error codes stored in memory. If E000 is displayed, there are no stored error codes.
Solid	- - -	To exit error code recall mode push and hold button until solid three horizontal bars appear, then release button. Note - Error codes are not cleared.
Solid	c	To clear error codes stored in memory, continue to hold push button while the 3 horizontal bars are displayed. Release push button when solid c is displayed.
Blinking	c	Hold push button for three seconds to confirm command to delete codes. Error codes are cleared.

**Note once the error history is deleted it cannot be recovered. After the history is deleted, the unit will reset itself.*

Table 12. Field Test and Program Menu Options

Display	Display and action (normal operation)	Display and action (configuration and test mode)
Power -UP	Display string displays > number of unit stages > pause > RC or HP unit > pause > unit capacity in BTUs > pause > RPM setting of outdoor fan. If 3 horizontal bars are displayed during any sequence of this string, it indicates that the specific parameter is not configured.	
-	Idle mode — decimal blinks at 1 Hertz > 0.5 second ON, 0.5 second OFF	
A	A in the display string represents the ambient temperature in °F at the outdoor sensor on the outdoor unit.	Enter A test mode: Display will string active error code(s) E , ambient A , coil c and discharge d temperature in °F at outdoor unit.
c	Enter A test mode: Display will string active error codes (E), ambient (A), coil (c) and discharge (d) temperature in °F at outdoor unit.	
d	d - dehumidification mode string > d pause > F (Outdoor fan) RPM > pause > A (ambient temp displayed) > pause > repeat mode. IMPORTANT: On 2-stage unit R to DS link must be cut and correct RPM outdoor fan profile selected for outdoor fan to operate at lower RPM speed when EDA is active.	Enter d test mode: Forced defrost. (System must be configured as HP. Unit must be running in heating mode). Test defrost will terminate when coil terminate temperature is reached (or 10 seconds, whichever is longer) or 14 minutes if coil temperature remains below terminate temperature or by pushing button down for less than 2 seconds. Enter A test mode: Display will string active error codes E , ambient A , coil c and discharge d temperature in °F at outdoor unit.
d F	d F displays when system is in defrost mode - unit must be running in heating mode, outdoor ambient must be below 65°F and outdoor coil temperature must be below defrost termination temperature.	
F *	F in the display string indicates RPM setting output on terminals PWM and com (used with EBM motors). RPM displayed does not apply to motor connected on ECM Y1 and ECM Y2.	Enter F test mode: Control outputs DC Voltage onto PWM and com terminals. Outdoor fan will cycle ON for 10 minutes at 490 RPM. To exit test - Push and hold button until three horizontal bars display. Release button, outdoor fan will cycle OFF. (Test DOES NOT output DC voltage to ECM Y1 and ECM Y2 terminals)
H1	Heat stage 1 string display > pause > F outdoor fan RPM displayed > pause > A (ambient temperature displayed > pause > repeat mode.	
H2	Heat stage 2 string display > pause > F outdoor fan RPM displayed > pause > A ambient temperature displayed > pause > repeat mode.	

** Information will be displayed but does not apply to this product*

Configuring Unit Capacity (Note - Control must be in Idle Mode)		
Solid	PC	Release push button — Allows user to select Unit Capacity. IMPORTANT: Field replacement control may need to be manually configured to validate outdoor unit capacity. Refer to unit nameplate model number for capacity in 1,000 of BTUs. (18, 24, 30, 36, 42, 48, 60)
Blinking	PC	Push and hold button — Control will display unit capacity number 3 seconds. When the correct unit capacity number is displayed, release button. Selected code will flash for a 10 second period. During that period, hold push button for 3 seconds to store code. Once code is stored control will automatically exit <i>Field Test Mode</i> . If 10 second period expires or push button is held less than 3 seconds, control will automatically exit field test mode and go into idle mode without storing unit capacity Number. If this happens, configuring procedure must be repeated.

Table 13. Field Test and Program Menu Options (continued)

Display	Code	Procedure
Solid	Pt	Release push button — Allows user to select type and number of stages on outdoor unit. IMPORTANT: Field replacement control may need to be manually configured to validate outdoor unit fan RPM setting is right for unit capacity. See RPM table on unit wiring diagram for proper RPM settings. Type and number of stages: 1AC, 2AC, 1HP, 2HP – AC – air conditioning and HP – Heat Pump
Blinking	Pt	Push and hold button — Control will display type and number of stages 3 seconds. When the correct type and number of stages is displayed, release button. Selected code will flash for a 10 second period. During that period, hold push button for 3 seconds to store code. Once code is stored control will automatically exit <i>field test mode</i> . If 10 second period expires or push button is held less than 3 seconds, control will automatically exit field test mode and go into idle mode without storing type and number of stages. If this happens, configuring procedure must be repeated.

MAINTENANCE

WARNING

Before performing maintenance operations on system, turn the electric power to unit OFF at disconnect switch(es). Unit may have multiple power supplies. Electrical shock could cause personal injury or death.

Maintenance and service must be performed by a qualified installer or service agency.

At the beginning of each cooling season, the system should be checked as follows:

1. Clean and inspect condenser coil. Coil may be flushed with a water hose. Be sure the power is off before using water to clean the coil.
2. Outdoor fan motor is pre-lubricated and sealed. No further lubrication is needed.
3. Visually inspect connecting lines and coils for evidence of oil leaks.
4. Check wiring for loose connections.
5. Check for correct voltage at unit (with unit operating).
6. Check amp-draw outdoor fan motor.

Unit nameplate _____ Actual _____

NOTE: *If owner complains of insufficient cooling, the nit should be gauged and refrigerant charge checked. Refer to the **Refrigerant Charging** section on page 14.*

Indoor Coil

1. Clean coil, if necessary.
2. Check connecting lines and coils for evidence of oil leaks.
3. Check condensate pan line and clean, if necessary.

Indoor Unit

1. Clean or change filters.
2. Adjust blower speed for cooling. Measure the pressure drop over the coil to determine the correct blower CFM.
3. Belt drive blowers: Check belt for wear and proper tension.
4. Check all wiring for loose connections.
5. Check for correct voltage at unit (with unit operating).
6. Check amp-draw on blower motor.

Unit nameplate _____ Actual _____

HOMEOWNER INFORMATION

In order to ensure peak performance, your system must be properly maintained. Clogged filters and blocked airflow prevent your unit from operating at its most efficient level.

WARNING

Turn all electric power to unit OFF at disconnect switch(es) before performing any maintenance operations on system. Unit may have multiple power supplies. Electrical shock could cause personal injury or death.

Ask your dealer to show you where the indoor unit's filter is located. It will be either at the indoor unit (installed internal or external to the cabinet) or behind a return air grille in the wall or ceiling in your home. Check the filter monthly and clean or replace it as needed.

Disposable filters should be replaced with a filter of the same type and size. If you are unsure of the filter you need for your system, contact your dealer.

Many indoor units are equipped with reusable foam filters. These filters can be cleaned with a mild soap and water solution. Rinse the filter thoroughly and let dry completely before returning to unit or grille.

The filter and all access panels must be in place any time the unit is in operation.

Some systems are equipped with an electronic air cleaner, designed to remove the majority of airborne particles from the air passing through the cleaner. If your system includes an electronic air cleaner, ask your dealer for maintenance instructions.

Inspect and clean indoor coil. The indoor evaporator coil is equipped with a drain pan to collect condensate formed as the system removes humidity from the inside air. Have your dealer show you the location of the drain line and how to check for obstructions. This also applies to an auxiliary drain, if one is installed.

Inspect and clean outdoor coil:

Make sure no obstructions restrict airflow to the outdoor unit. Leaves, trash, or shrubs crowding the unit can cause it to work harder and use more energy. Keep shrubbery trimmed away from the unit and periodically check for debris which collects around the unit.

The outdoor coil may require frequent cleaning, depending on environmental conditions. Clean the outdoor coil with an unpressurized water hose to remove surface contaminants and debris. It may be necessary to flush the outdoor coil more frequently if it is exposed to substances which are corrosive or which block airflow across the coil (such as pet urine, cottonwood seeds, etc...).

Start-Up and Performance Checklist

Job Name _____ Job No. _____ Date _____

Job Location _____ City _____ State _____

Installer _____ City _____ State _____

Unit Model No. _____ Serial No. _____

Service Technician _____ Nameplate Voltage _____

Rated Load Ampacity _____ Compressor Amperage _____ Outdoor Fan _____

Maximum Fuse or Circuit Breaker _____

Electrical Connections Tight? Indoor Filter Clean? Supply Voltage (Unit Off) _____

Indoor Blower RPM _____ S.P. Drop Over Indoor (Dry) _____

Outdoor Coil Entering Air Temperature _____ Voltage with Compressor Operating _____

Discharge Pressure _____ Vapor Pressure _____

Refrigerant Lines: Charge Checked? Outdoor Fan Checked?

Refrigerant Lines: Leak Checked? Properly Insulated?

Service Valves: Fully Opened? Caps Tight?

Thermostat: Calibrated? Properly Set? Level?

4SCU16LS124-160 Wire Diagram

537444-01

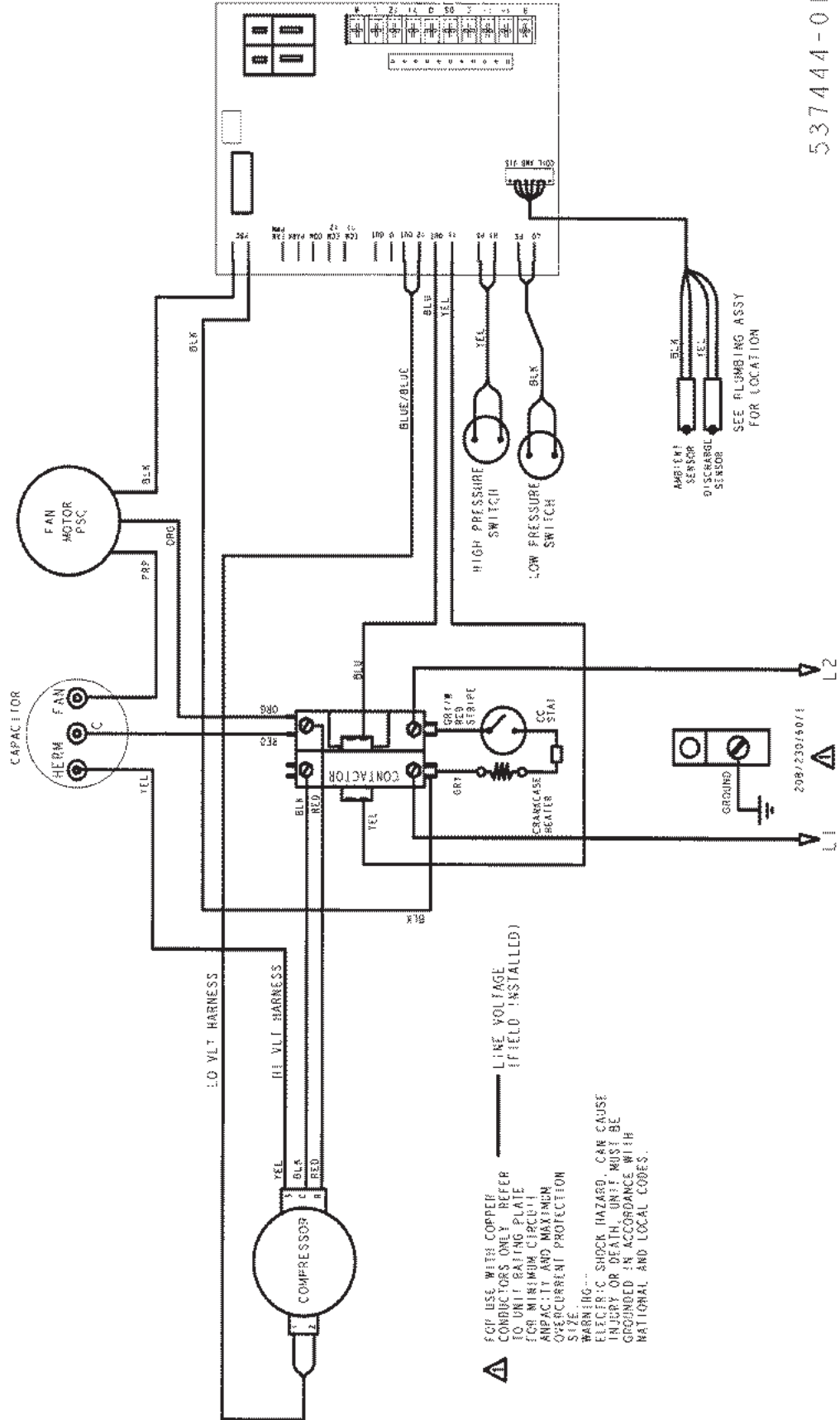

4SCU18LS124-160 Wiring Diagram

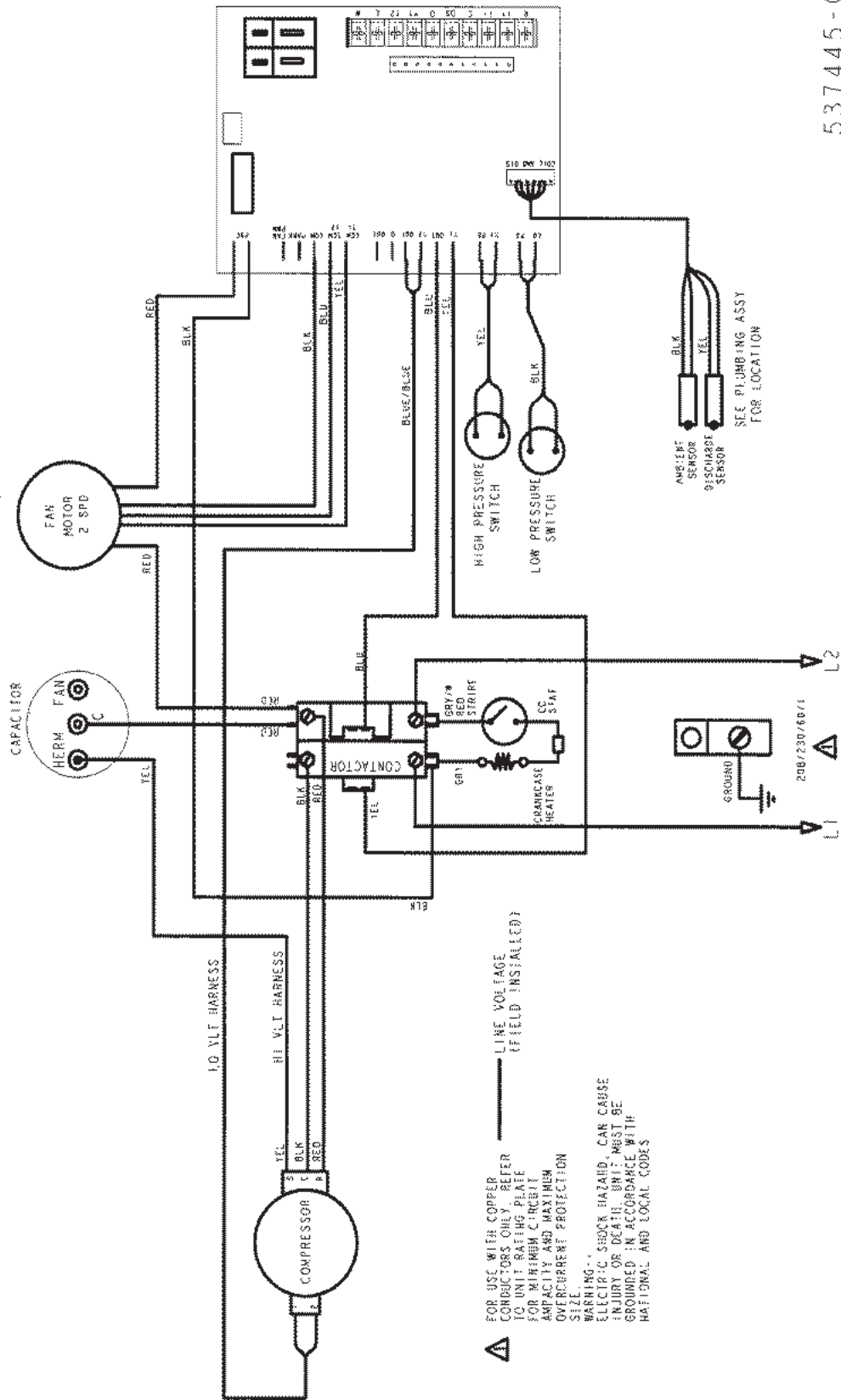

537445-01

**ALLIED AIR ENTERPRISES
EQUIPMENT LIMITED WARRANTY
APPLIES IN U.S.A. AND CANADA ONLY
FAILURE TO MAINTAIN YOUR EQUIPMENT WILL VOID THIS WARRANTY**

COVERED EQUIPMENT

The following Allied Air Enterprises heating and cooling equipment is covered by the Limited Warranty,

Condensing Units: 2SCU13, 4SCU13, 4SCU14, 4SCU16, 4SCU18, 2AC13, 2AC14, 4AC13, 4AC14

Heat Pumps: 2SHP13, 4SHP13, 2SHP14, 4SHP14, 4SHP16, 4SHP18, 2HP13, 2HP14, 4HP13, 4HP14, 4HP16, 4HP18

Gas Furnaces: G1N80, G1D80, G2D80, G1D91, G1D93, G2D93, G2D95, FPBB, CG80, CG90, CG92, CG93, CG95, A97, A96, A95, A952V, A93, A80, 95G2, 95G2V, 95G1, 92G1, 80G2, 80G1

Oil Furnaces: LBR80, LBF80, LHF80, LUF80, LHR80, L83, RLUF, RLBF, RLBR, RLBU, RLHF, RLHR, ODH, OLFA, OLRA, OUFA

Electric Furnaces: EFC, EFV

Evaporator Coils: EC, EU, EH, EM

Air handlers: BCS2, RBCS2

Package Equipment: 2PCE13, 4PCE13, 4PCE15, 2PGE13, 4PGE13, 4PGE15, 2PHP13, 4PHP13, 4PHP15, 2SG13, 2SH13, 2SA13, RGE13, RPGE13, RHP13, RCE13, RPHP13, RPCE13

Unit Heaters: LF24 (30,000 to 75,000 Btuh units)

PARTS and COMPRESSOR COVERAGE

The covered equipment, parts and compressor are warranted by Allied Air for a period of five (5) years from the date of the original installation, when installed in a residential application (which includes homes, duplexes, apartments and condominiums). For non-residential applications, the covered equipment and parts are warranted for a period of one (1) year and compressor is warranted for five (5) years from the date of the original installation. If, during this period, a covered component fails because of a manufacturing defect, Allied Air will provide a free replacement part to the owner through a licensed service contractor utilizing an Allied Air distributor. The purchaser must pay shipping charges and all other costs of warranty service. Allied Air will not pay labor involved in diagnostic calls or in removing, repairing, servicing or replacing parts. Such cost may be covered by a separate warranty provided by the installer.

HEAT EXCHANGER EXTENDED COVERAGE

All covered heat exchangers are warranted by Allied Air for a period of twenty (20) years from the date of original installation, when installed in a residential application. Heat exchangers in all non-residential applications are warranted for a period of ten (10) years. LF24 (30,000 to 75,000 Btuh) units are covered for the following: Aluminized heat exchanger - Ten (10) years.

Heat Exchanger Availability: If a replacement heat exchanger is no longer available for a unit covered by this Limited Warranty, Allied Air will allow a credit toward the purchase of an equivalent Allied Air furnace (at the current suggested distributor's cost).

NOTE: If the date of original installation cannot be verified, the warranty period will be deemed to begin ninety (90) days after the date of manufacture. The LF24 unit heaters are not eligible for the extended warranty coverage.

EXCLUDED COMPONENTS

The following components are expressly not covered by this Limited Warranty: cabinets, cabinet pieces, air filters, driers, refrigerant, refrigerant line sets, belts, wiring, fuses, oil nozzles, unit accessories and any parts not affecting unit operation

CARE OF EQUIPMENT

All new Allied Air units must be properly installed, operated and maintained in accordance with the unit installation, operation and maintenance instructions provided with each Allied Air unit. Failure to maintain the equipment per Allied Air instructions will void this Limited Warranty.

WARRANTY PROCEDURE

When service or warranty parts are required:

1. Call a local licensed service dealer or contractor.
2. If the installing dealer is unable to provide warranty service, check online at www.alliedair.com.
3. Be prepared to furnish the following information:
 - a. complete model and serial number;
 - b. proof of required periodic maintenance, installation date and location; and
 - c. an accurate description of the problem.

WARRANTY LIMITATIONS

1. This Limited Warranty is void if the covered equipment is removed from the original installation site.
2. This Limited Warranty does not cover damage or defect resulting from:
 - a. flood, wind, fire, lightning, mold, or installation and operation in a corrosive atmosphere, or otherwise in contact with corrosive materials (chlorine, fluorine, salt, recycled waste water, urine, fertilizers, or other damaging substances or chemicals); accident, or neglect or unreasonable use or operation of the equipment including operation of electrical equipment at voltages other than the range specified on the unit nameplate (includes damages caused by brownouts);
 - b. modification, change or alteration of the equipment, except as directed in writing by Allied Air;
 - c. operation with system components (indoor unit, outdoor unit and refrigerant control devices) which are not an ARI match or meet the specifications recommended by Allied Air;
 - d. operation of furnaces with return air temperatures of less than 60°F (16°C) or operation of a furnace field installed downstream from a cooling coil; and
 - e. use of contaminated refrigerant or refrigerant not compatible with the unit.

The installation of replacement parts under the terms of this Limited Warranty does not extend the original warranty period.

Allied Air makes no express warranties other than the Limited Warranty specified above. All implied warranties, including the implied warranties of merchantability and fitness for a particular purpose, are excluded to the extent legally permissible. Should such exclusion or limitation of this Limited Warranty be unenforceable, such implied warranties are in any event limited to a period of one (1) year. Liability for incidental and consequential damages is excluded. Some states do not allow limitation of incidental damages, so these limitations or exclusions may not apply to you. Allied Air will not pay electricity or fuel costs, or increases in electricity or fuel costs, for any reason whatsoever, including additional or unusual use of supplemental electric heat. This Limited Warranty does not cover lodging expenses or labor charges.

Allied Air shall not be liable for any default or delay in performance under this Limited Warranty caused by any contingency beyond its control.

This Limited Warranty gives you specific legal rights, and you may also have other rights which vary from state to state.

NOTE TO CUSTOMER:

Please complete information below and retain this warranty for your records and future reference.

Outside Unit Model Number: _____ Serial Number: _____ Installed Date: _____

Furnace / Air Handler: _____ Serial Number: _____ Installed Date: _____

Indoor Coil Model Number: _____ Serial Number: _____ Installed Date: _____

Installing Company Name: _____ Phone: _____

Installing Company Address: _____ State/Province: _____ Zip/Postal Code: _____



215 Metropolitan Drive - West Columbia - SC - 29170

© 2008 Allied Air Enterprises Litho U.S.A. FORM W-2008-2 (1/19/2012)

5-YEAR LIMITED EXTENDED PARTS WARRANTY

Allied Air Enterprises Inc. ("Allied Air") provides its air conditioning and heating products with a Standard Limited Parts Warranty for five (5) years. This additional 5-Year Limited Extended Parts Warranty is in addition to and is intended to supplement Allied Air's Standard Limited Parts Warranty. As such, Allied Air provides for a total of 10-years of limited warranty coverage (Standard Limited Parts Warranty plus additional 5-Year Limited Extended Parts Warranty).

This 5-Year Limited Extended Parts Warranty applies only to the original purchaser of the equipment and cannot be transferred. If during the coverage period, a covered part fails because of a defect in materials or workmanship under normal use and maintenance, Allied Air will provide a free replacement part to the purchaser through a licensed service contractor utilizing an authorized Allied Air distributor. The purchaser must pay shipping costs and all other costs of warranty service. Allied Air will not pay labor involved in diagnostic calls or in removing, repairing, servicing or replacing parts.

EXTENDED COVERAGE -

PARTS/COMPRESSORS

Covered equipment and parts are warranted by Allied Air for a total of **10 YEARS** (Standard Limited Parts Warranty) from installation, except as provided below

HEAT EXCHANGERS

Covered residential heating equipment's heat exchanger is warranted by Allied Air for a LIMITED LIFETIME from date of original installation, except as provided below.

EXCLUDED COMPONENTS -

The following components are expressly not covered by this 5-Year Limited Extended Parts Warranty: cabinets, cabinet pieces, air filters, driers, refrigerant, refrigerant line sets, belts, wiring, fuses, oil nozzles, unit accessories, R-22 compressors, and any parts not affecting unit operation.

REQUIREMENTS FOR EXTENDED COVERAGE-

1. The unit is an Armstrong Air, AirEase, Ducane, or Concord branded unit;
2. The unit is installed in a residential application, which is an owner-occupied single-family residence. No commercial applications are allowed;
3. **The unit is properly registered at www.alliedair.com with Allied Air within 60-days after the original date of installation or occupancy.¹ To register, follow the directions and complete the online warranty registration at www.alliedair.com. For customer inquiries, contact Allied Air at 1-800-448-5872.**
4. The unit is part of a complete ARI matched system and installed by a state certified or licensed contractor in accordance with the unit installation, operation, and maintenance instructions provided with the unit.
5. Coils and air handlers are covered only when they are branded Armstrong, AirEase, Ducane, Concord or ADP and are purchased and newly installed as a system along with a qualifying unit. Except for ADP-branded products, coverage of other third party coils and air handlers are specifically excluded from this 5-Year Limited Extended Parts Warranty.
6. Installation of the unit takes place on or after October 3, 2008.

If this 5-Year Limited Extended Warranty does not apply, then parts are warranted under the Standard Limited Parts Warranty for a period of **5 YEARS** and heat exchangers for **20 YEARS**. If the Standard Limited Parts Warranty periods differ from the original warranty certificate, the periods stated on the original warranty certificate apply.

This 5-Year Limited Extended Parts Warranty does not apply to, and no warranty is offered by Allied Air, on any unit ordered over the internet. Proof of purchase may be required.

Any part replaced pursuant to this 5-Year Limited Extended Parts Warranty is warranted only for the unexpired portion of the limited extended warranty term remaining for the original part. The installation of replacement parts under the terms of this 5-Year Limited Extended Parts Warranty does not extend the warranty period.

Steps for obtaining replacement parts under this 5-Year Limited Extended Parts Warranty:

If you suspect a defect in your equipment, please contact the installer of the unit to obtain assistance. If unsuccessful, please contact an Allied Air dealer or distributor in your area. If unable to obtain local assistance, refer to Allied Air's website (www.alliedair.com) or contact Allied Air at 800-448-5872.

Allied Air is specifically not responsible for:

1. Damage or repairs required as a result of flood, fire, wind, lightning strike (to the home or unit), corrosive atmosphere, contact with corrosive material (chlorine, fluorine, salt, recycled waste water, fertilizers or other damaging substances) or other conditions beyond the control of Allied Air;
2. Use of parts, accessories, or refrigerant not compatible with the unit;
3. Modification, change or alteration of the unit, except as expressly directed in writing by Allied Air;
4. Improper use, accident, neglect or unreasonable use or operation of the unit, including operation of electrical equipment at voltages other than the range specified on the unit nameplate;
5. Operation with system parts (indoor unit, outdoor unit and refrigerant control devices) which are not ARI matched or do not meet the specifications recommended by Allied Air;
6. Damage or repairs required as a consequence of faulty or installation or application;
7. Normal maintenance as described in the installation and operating manual, such as cleaning of coils, filter cleaning and/or replacement and lubrication; and
8. Changes in the appearance or sound of the unit that do not affect its performance.

This 5-Year Limited Extended Parts Warranty is an extension of Allied Air's Standard Limited Parts Warranty. **ANY IMPLIED WARRANTY OF MERCHANTABILITY OR FITNESS FOR A PARTICULAR PURPOSE ON THIS PRODUCT IS LIMITED IN DURATION TO THE TERM OF THIS LIMITED EXTENDED WARRANTY.** Some states and provinces do not allow limitations on how long an implied warranty lasts, so the above limitation may not apply to you.

ALLIED AIR SHALL IN NO EVENT BE LIABLE FOR INCIDENTAL OR CONSEQUENTIAL DAMAGES, INCLUDING BUT NOT LIMITED TO EXTRA UTILITY EXPENSES OR DAMAGES TO PROPERTY. Some states and provinces do not allow the exclusion or limitation of incidental or consequential damages, so the above limitation or exclusion may not apply to you

The parties intend this writing as a final expression of their agreement with respect to warranties. Allied Air makes no other warranty beyond that which is expressly contained in this writing.

Allied Air shall not be liable for any default or delay in performance under this warranty caused by any contingency beyond its control, including the unavailability of replacement parts.

This warranty gives you specific legal rights, and you may also have other rights that vary from state to state or province to province.

¹Excludes residents of states or provinces where registration requirements are prohibited, such as California and Quebec. Residents of these states or provinces may either register as noted above or provide proof of when the unit was purchased and installed, such as an original invoice from the contractor with the Owner's name, address, purchase date, serial and model number.