

4SCU13LB

PRODUCT SPECIFICATIONS

13 SEER SPLIT SYSTEM AIR CONDITIONER

FORM NO. 4SCU13LB-100 (07/2014)

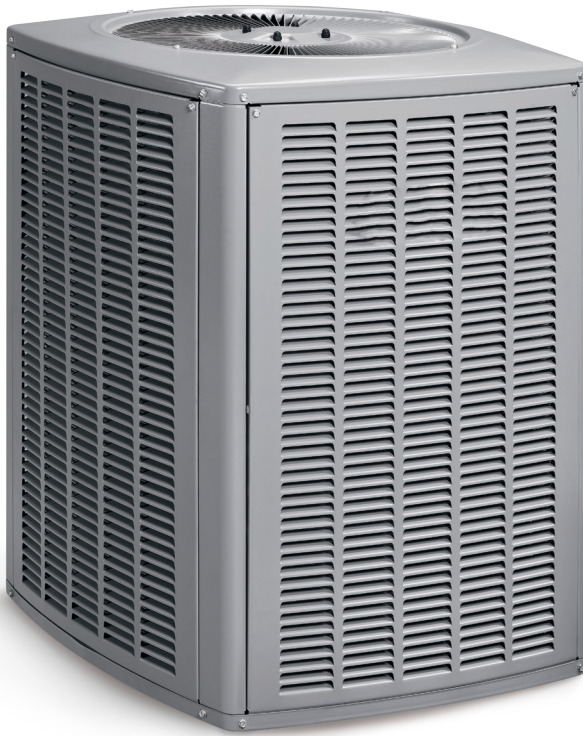

COMPRESSOR

- High-efficiency scroll compressor
- R410a refrigerant
- Grommet-mounted compressor for quiet operation
- Protected against high temperature motor overload conditions

CABINET

- Full metal louvered panel remove with just two (2) screws per panel for easy coil cleaning and service
- Controls located in corner for easy installation and service
- Rounded corners for safety and attractive, clean appearance
- Baked polyester paint finish over galvanized steel for maximum durability
- External gauge ports for easy service
- Stamped, one piece top

COMPONENTS

- Filter drier shipped loose for installation flexibility
- Service valves positioned for quick installation and easy service
- Indoor coil orifice shipped with outdoor unit for quick installation and capacity
- High pressure switch factory installed

COIL

- Enhanced aluminum fins and copper tubing for high efficiency and capacity
- Raised coil prevents debris from collecting in bottom of coil and causing loss of airflow

DESIGN

- Designed for ambients up to 125°F

ACCESSORIES

- Low ambient control
- Thermal expansion valve kits
- Crankcase heater
- Sound blanket
- Loss of charge kit
- Time delay
- Short cycle protection
- Freezestat kit
- Hard start kit

WARRANTY

10 year limited warranty on compressor, , 10 year limited warranty on all parts, extended warranty available*

**Warranty provides for a total of 10 years of limited warranty coverage (Standard 5-year limited parts warranty plus an additional 5-year limited extended parts warranty). Warranty must be registered online within 60 days of installation to qualify for 10-year coverage. Unregistered equipment defaults to 5-year coverage. Lifetime limited heat exchanger warranty applies to registered equipment only (Standard 20 years with no online registration). See full warranty at www.alliedair.com for terms, conditions and exclusions.*



Model Number Guide

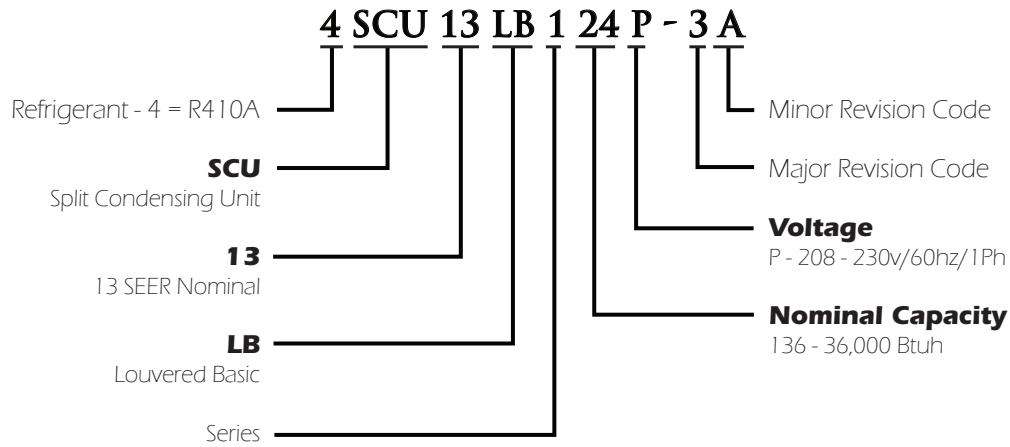

Physical and Electrical

Model	Voltage/Hz/Phase	Voltage Range	Min. Circuit Amp.	Max Over current Device (amps)	Compressor		Outdoor Fan Motor			Refrig. Charge+ (oz.)	Shipping Weight (lbs.)
					Rated Load (amps)	Locked Rotor (amps)	Rated Load (amps)	Rated HP	Nom. RPM		
4SCU13LB118P-3	208-230/60/1	197-253	10.9	15	8.1	39	0.7	1/10	1010	62	157
4SCU13LB124P-3	208-230/60/1	197-253	14.1	20	10.7	53	0.7	1/10	1010	63	157
4SCU13LB130P-3	208-230/60/1	197-253	15.6	25	11.6	59	1.1	1/5	1090	82	179
4SCU13LB136P-3	208-230/60/1	197-253	20.1	35	15.2	70	1.1	1/5	1090	84	188
4SCU13LB142P-3	208-230/60/1	197-253	28.1	45	21.1	90	1.7	1/4	825	104	205
4SCU13LB148P-3	208-230/60/1	197-253	31.9	50	24.1	100	1.7	1/4	825	124	198
4SCU13LB160P-3	208-230/60/1	197-253	29.4	50	22.1	125	1.7	1/4	830	144	211

Note:
Weights listed are unit weights with packaging
+ Factory charged for 15 feet ofline set. Adjust per installation instructions.

Dimensions (in.) & Sound Ratings

Model No.	Dimensions			Sound Rating dBA
	A - width	B - depth	C - Height	
4SCU13LB118P-3	24.75	26.75	25.75	74
4SCU13LB124P-3	24.75	26.75	25.75	74
4SCU13LB130P-3	24.75	26.75	29.75	74
4SCU13LB136P-3	24.75	26.75	29.75	74
4SCU13LB142P-3	29.38	31.25	29.75	79
4SCU13LB148P-3	29.38	31.25	33.75	79
4SCU13LB160P-3	29.38	31.25	29.75	80

Note:
Dimensions listed are unit sizes w/o packaging

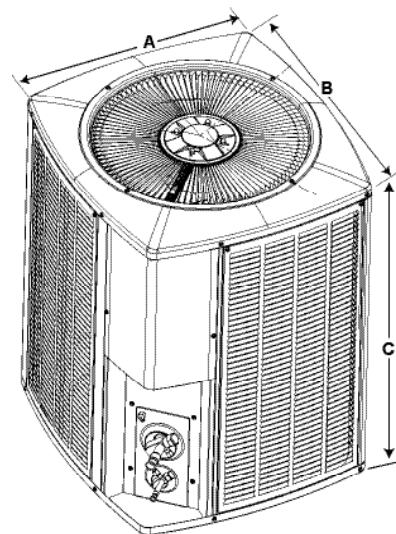

Accessories

Description	Where Used	Kit Number
Crankcase Heater	All models	93M04
Hard Start Kit	18	10J42
	24, 30, 36, 42, 48, 60	88M91
Low Ambient Kit	18, 24, 30, 36, 42, 48, 60	34M72
Sound Blanket	18, 24, 30, 36	14W00
	42, 48, 60	14W01
Short Cycle Protector	18, 24, 30, 36, 42, 48, 60	47J27
Freezestat	3/8 tubing	93G35
Time Delay Relay	18, 24, 30, 36, 42, 48, 60	58M81
Loss of Charge Kit	18, 24, 30, 36, 42, 48, 60	84M23